

# ULTRA S

## CARATTERISTICHE COSTRUTTIVE / CONSTRUCTION FEATURES CARACTERÍSTICAS CONSTRUCTIVAS / CARACTÉRISTIQUES D'EXÉCUTION

<b>Corpo pompa</b> <b>Pump body</b>	acciaio cromo-nichel AISI 304 stainless steel AISI 304
<b>Cuerpo bomba</b>	acero cromo-níquel AISI 304
<b>Corps de pompe</b>	acier chrome-nickel AISI 304
<b>Supporto motore</b> <b>Motor bracket</b>	alluminio aluminium
<b>Soporte motor</b> <b>Support moteur</b>	aluminio aluminium
<b>Giranti, diffusori</b> <b>Impellers, diffusers</b>	acciaio cromo-nichel AISI 304 stainless steel AISI 304
<b>Rodetes, difusores</b> <b>Turbines, diffuseurs</b>	acero cromo-níquel AISI 304 acier chrome-nickel AISI 304
<b>Tenuta meccanica</b> <b>Mechanical seal</b>	ceramica-grafite ≤ 6 giranti grafite-carburo di silicio ≥ 7 giranti ceramic-graphite ≤ 6 impellers graphite-silicon carbide ≥ 7 impellers
<b>Sello mecánico</b> <b>Garniture mécanique</b>	cerámica-grafito ≤ 6 rodetes grafito-carburo de silicio ≥ 7 rodetes céramique-graphite ≤ 6 turbines graphite-carbure de silicium ≥ 7 turbines
<b>Albero motore</b> <b>Motor shaft</b>	acciaio cromo-nichel AISI 303 stainless steel AISI 303
<b>Eje motor</b> <b>Arbre moteur</b>	acero cromo-níquel AISI 303 acier chrome-nickel AISI 303
<b>Temperatura del liquido</b> <b>Liquid temperature</b>	
<b>Temperatura del líquido</b> <b>Température du liquide</b>	-15 ÷ +110 °C
<b>Pressione di esercizio</b> <b>Operating pressure</b>	
<b>Presión de trabajo</b> <b>Pression de fonctionnement</b>	max 8,5 bar
<b>MOTORE / MOTOR / MOTOR / MOTEUR</b>	
<b>Motore 2 poli a induzione</b>	3~ 230/400V-50Hz
<b>2 pole induction motor</b>	1~ 230V-50Hz
<b>Motor de 2 polos a inducción</b>	(con termoprotettore fino a 1,85kW with thermal protection up to 1,85 kW con protección térmica hasta 1,85 kW)
<b>Moteur à induction à 2 pôles</b>	avec protection thermique jusqu'à 1,85 kW
<b>Classe di isolamento</b> <b>Insulation class</b>	F
<b>Clase de aislamiento</b> <b>Classe d'isolation</b>	
<b>Grado di protezione</b> <b>Protection degree</b>	IP44
<b>Grado de protección</b> <b>Protection</b>	

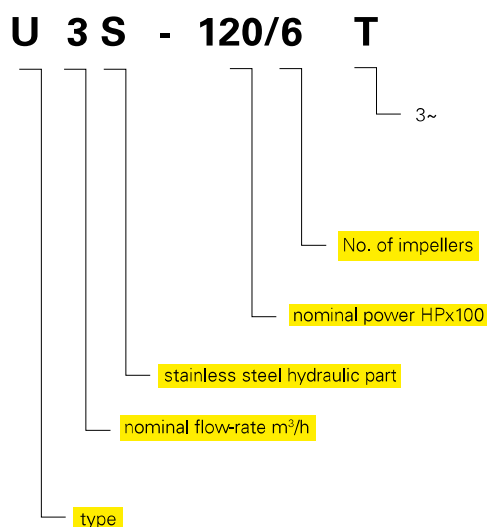

ULTRA 3S



ULTRA 5S



ULTRA 7S



ULTRA 9S



ULTRA 18S



Pompe centrifughe multistadio orizzontali. Adatte alla movimentazione di liquidi non carichi; sistemi di pressurizzazione; irrigazione; acque potabili o con glicole in soluzione; trattamento acque; industria alimentare; riscaldamento e condizionamento; sistemi di lavaggio.

Stainless steel multistage horizontal pumps. Pumping of clean non-loaded fluids; pressurizing system; irrigation; drinking and glycol water; water treatment; heating and air conditioning; washing system.

Bombas centrífugas multietapas horizontales. Bombeo de líquidos químicamente y mecánicamente no agresivos; sistemas de presurización; riegos; agua potable o con glicol; tratamientos del agua; industria alimenticia; calefacción y refrigeración; sistemas de lavado.

Pompes centrifuges multicellulaires horizontales. Pompage d'eaux propres non chargées; groupes de surpression; irrigation; eau potable ou solution de glycol; traitement des eaux; industrie alimentaire; chauffage et climatisation; stations de lavage auto.

ULTRA S

3 S

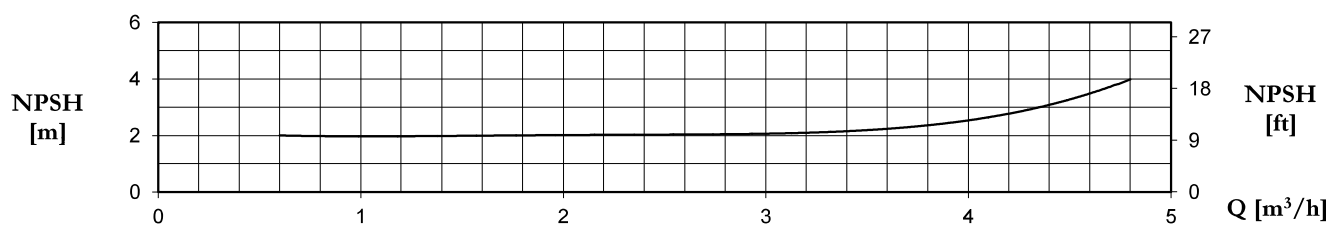
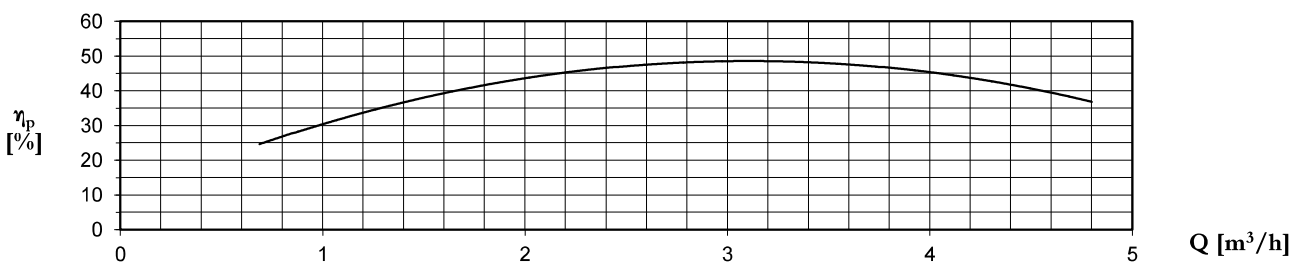
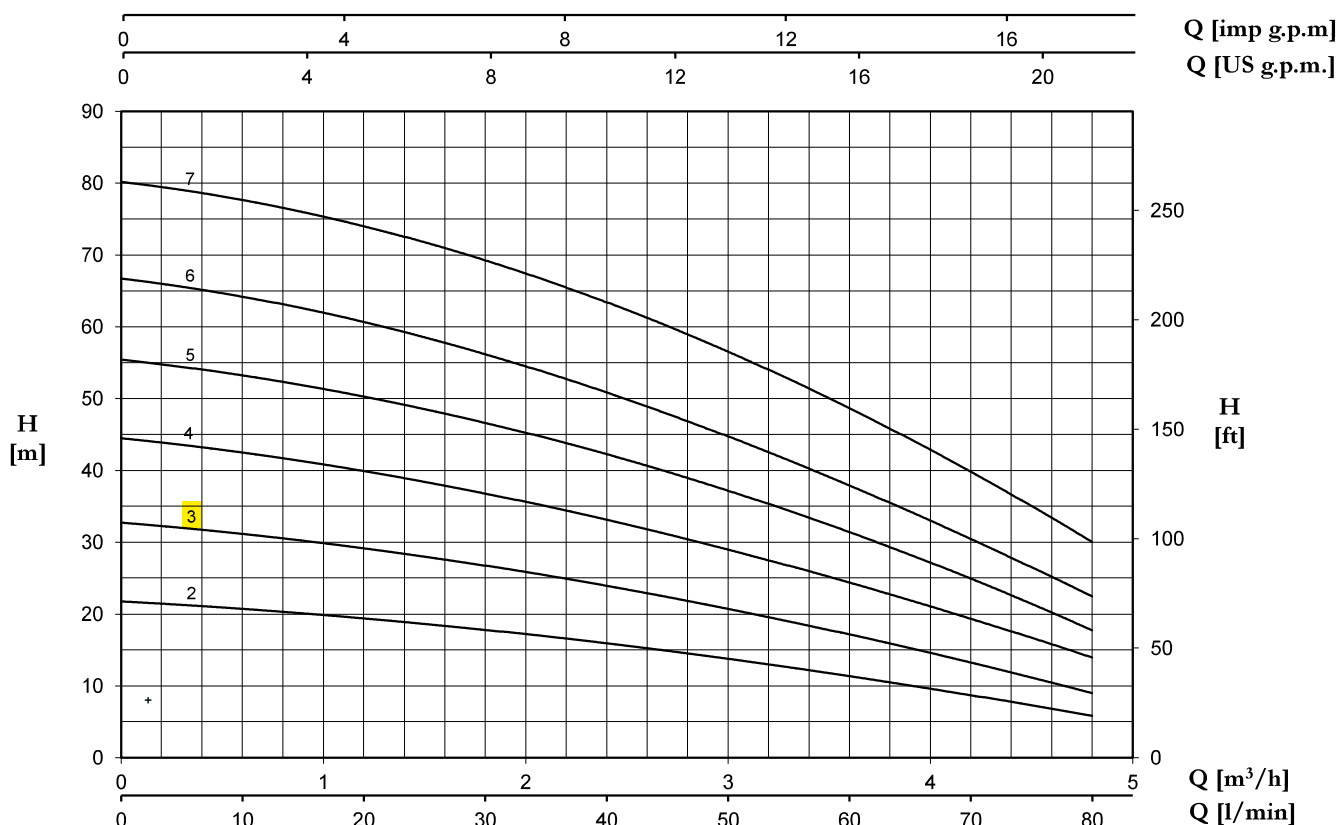

TYPE		P2		P1 (kW)		AMPERE		Q (m³/h - l/min)						
1~	3~	(HP)	(kW)	1~	3~	1~	3~	0	0,6	1,2	1,8	2,4	3,6	4,8
								0	10	20	30	40	60	80
								H (m)						
						1x230 V 50 Hz	3x400 V 50 Hz							
U 3S-50/2	U 3S-50/2T	0,5	0,37	0,41	0,41	1,8	0,9	21,7	20,9	19,3	17,8	15,9	11,4	5,8
<b>U 3S-70/3</b>	<b>U 3S-70/3T</b>	<b>0,7</b>	<b>0,51</b>	<b>0,61</b>	<b>0,58</b>	<b>2,7</b>	<b>1,1</b>	<b>32,7</b>	<b>31,2</b>	<b>29,2</b>	<b>26,7</b>	<b>23,9</b>	<b>17,2</b>	<b>9</b>
U 3S-90/4	U 3S-90/4T	0,9	0,66	0,83	0,8	3,6	1,7	44,3	42,8	40	36,4	33,2	24,5	13,9
U 3S-100/5	U 3S-100/5T	1	0,75	0,99	0,92	4,4	1,7	55,3	53,5	50,3	46,5	42,1	31,6	17,7
U 3S-120/6	U 3S-120/6T	1,2	0,9	1,11	1,11	5,1	2,5	66,6	64,4	60,8	56	50,7	38,1	22,4
U 3S-150/7	U 3S-150/7T	1,5	1,1	1,38	1,31	6,4	2,7	80,1	77,7	74,2	69,1	63,3	48,8	30

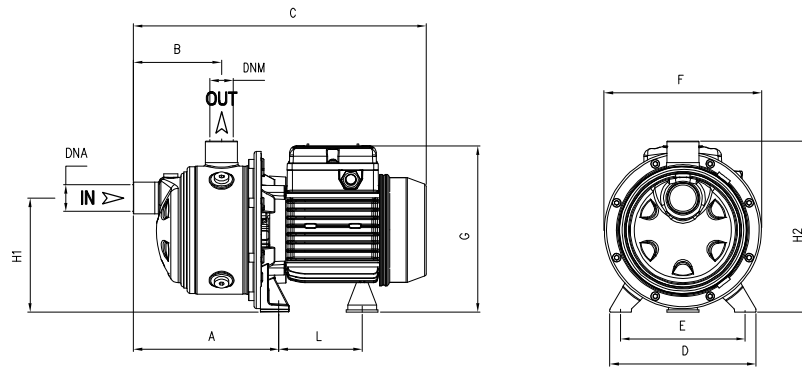

TYPE	DIMENSIONS (mm)										Kg	DNA	DNM
	A	B	C	D	E	F	G	L	H1	H2			
U 3S-50/2	166.8	103	333	164	140	178	190	93.7	128	192	7	1" G	1" G
U 3S-70/3	166.8	103	333	164	140	178	190	93.7	128	192	8		
U 3S-90/4	190.8	127	357	164	140	178	190	93.7	128	192	9,5		
U 3S-100/5	214.8	151	404	164	140	178	203	104.7	128	192	12		
U 3S-120/6	238.8	175	428	164	140	178	203	104.7	128	192	13		
U 3S-150/7	262.8	199	483	164	140	201	211	128.2	134	198	16		
U 5S-70/2	166.8	103	333	164	140	178	195	93.7	128	192	7,5		
U 5S-80/3	166.8	103	357	164	140	178	203	93.7	128	192	10		
U 5S-120/4	190.8	127	380	164	140	178	203	104.7	128	192	12		
U 5S-150/5	214.8	151	436	164	140	201	211	128.2	134	198	15		
U 5S-180/6	238.8	175	459	164	140	201	211	128.2	134	198	16,5		
U 5S-200/7	262.8	199	483	164	140	201	211	128.2	134	198	17,5		

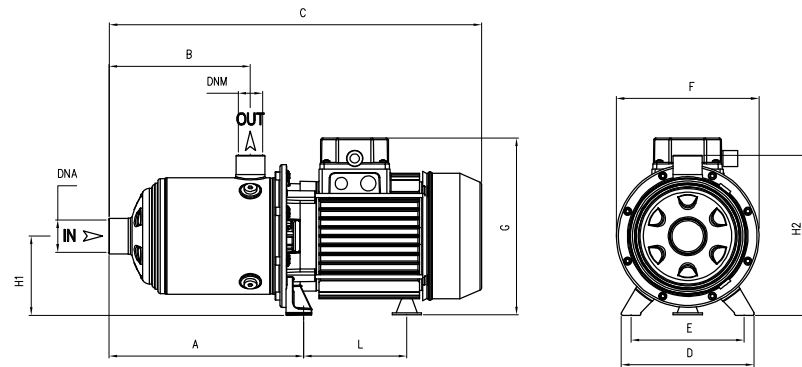

TYPE	DIMENSIONS (mm)										Kg	DNA	DNM
	A	B	C	D	E	F	G	L	H1	H2			
U 7S-100/2	166.8	103	356	164	140	178	203	104.7	103	192	10,5	1" 1/4 G	1" G
U 7S-120/3	166.8	103	356	164	140	178	203	104.7	92	192	11,5		
U 7S-180/4	190.8	127	411	164	140	201	211	128.2	98	198	15		
U 7S-250/5	214.8	151	436	164	140	201	211	128.2	98	198	17,5		
U 7S-300/6	238.8	175	M 503	164	140	201	M 229	M 148.2	M 103	M 203	M 19,5		
			T 459				T 211		T 128.2		T 98		
U 7S-350/7	262.8	199	527	164	140	201	229	148.2	92	203	20		
U 9S-100/2	185.8	118	375	164	140	178	203	104.7	98	192	10,5	1" 1/2 G	1" 1/4 G
U 9S-150/3	185.8	118	375	164	140	201	211	128.2	98	198	14		
U 9S-200/4	215.8	148	436	164	140	201	211	128.2	98	198	16		
U 9S-250/5	245.8	178	464	164	140	201	211	128.2	98	198	18		
U 18S-180/2T	201	141	432	164	140	201	211	128.2	98	198	14	2" G	1" 1/2 G
U 18S-250/3T	238.5	141	432	164	140	201	211	128.2	98	198	16		
U 18S-400/4T	276	178,5	514	164	140	201	229	148,2	103	203	22		

TYPE	TRUCK		CONTAINER	
	PALLET (cm)	N° pumps	PALLET (cm)	N° pumps
U 3S-50/2-90/4	80X120X150	84	80X120X175	96
U 3S-100/5-120/6	85X110X160	70	85X110X185	80
U 3S-150/7	80X120X150	42	80X120X175	49
U 5S-70/2	80X120X150	84	80X120X175	96
U 5S-80/3-120/4	85X110X160	70	85X110X185	80
U 5S-150/5	90X110X150	54	90X110X170	63
U 5S-180/6-200/7	80X120X150	42	80X120X175	49
U 7S-100/2-120/3	85X110X160	70	85X110X185	80
U 7S-180/4-250/5	90X110X150	54	90X110X170	63
U 7S-300/6T	80X120X150	42	80X120X175	49
U 7S-300/6 M-350/7T	80X120X145	35	80X120X170	42
U 9S-100/2	85X110X160	70	85X110X185	80
U 9S-150/3-200/4	90X110X150	54	90X110X170	63
U 9S-250/5	80X120X150	42	80X120X175	49
U 18S-180/2-250/3	90X110X150	54	90X110X170	63
U 18S-400/4	80X120X145	35	80X120X170	42

# ULTRA S

## QU'EST-CE QUE C'EST

Pompes horizontales multicellulaires en acier inoxydable. Pompage de fluides propres non chargés, système de pressurisation, irrigation, eau potable et glycolée, traitement de l'eau, chauffage et climatisation, système de lavage.

## APPLICATIONS



approvisionnement en eau et pressurisation pour l'irrigation des jardins et des petites cultures



Alimentation en eau et pressurisation pour installations domestiques et résidentielles

## CARACTÉRISTIQUES

Corps de pompe	Acier inoxydable AISI 304
Support moteur	Aluminium
Turbine	Noryl®
Garniture mécanique	Céramique-graphite ≤ 6 roues Graphite-carbure de silicium ≥ 7 roues
Arbre moteur	Acier inoxydable AISI 303
Température du liquide	-15 ÷ +110°C
Pression de service	Max 8,5 bars
Classe d'isolation	F

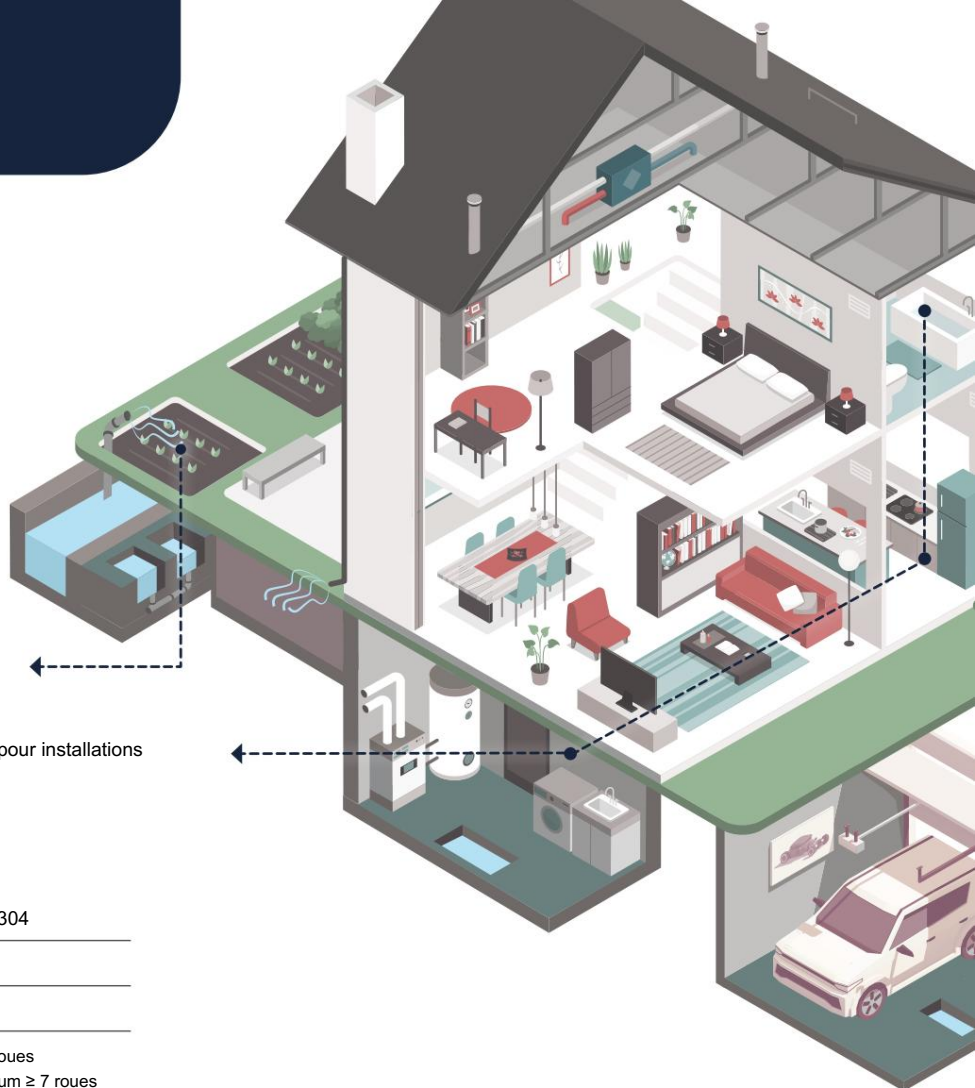

## PLUS



Super capacité d'aspiration



Extrêmement silencieux



Durabilité plus longue

## PERFORMANCE



0,5 à 4 CV



TÊTE  
Jusqu'à 83 mètres



DÉBIT  
Jusqu'à 420 l/min