



**CATALOGUE
2017**

EXPERT-BY-FACOM.COM

EXPERT
by **FACOM**



EXPERT

by FACOM

EXPERT by FACOM propose à tous les professionnels de l'industrie et de l'automobile, des solutions au juste rapport qualité-prix, robustes et design, dédiées à leur productivité. Des outils pour aller directement à l'essentiel : la satisfaction du travail bien fait.

Précision et sécurité

Les outils EXPERT sont conçus, développés et produits par les équipes R&D et les usines FACOM. Ils répondent au plus près aux besoins des professionnels de la maintenance industrielle et automobile.

Résistance, qualité et design

EXPERT by FACOM, ce sont des outils élaborés pour résister à un usage professionnel. Leur design est simple et unique, l'ensemble de la gamme est cohérent.

Juste valeur, ni plus, ni moins

Un rapport qualité/prix unique, pour aider chaque professionnel à rester compétitif.

Une gamme conforme aux normes internationales



Tous les outils EXPERT by FACOM sont conformes aux normes internationales DIN et ISO en vigueur.



Une marque solidement structurée
grâce aux moyens du leader mondial
de l'outillage à main et à sa présence
dans le monde entier.

**AMÉRIQUE
DU NORD**
États Unis

EUROPE
Allemagne
Autriche
Belgique
Espagne
France
Grèce
Italie
Pays-Bas
Portugal
Royaume Uni
Suisse

SCANDINAVIE
Danemark
Finlande
Norvège
Suède

**AFRIQUE
DU NORD**
Algérie
Maroc
Tunisie

MEA
Moyen orient
Afrique

**CENTRE LOGISTIQUE EUROPÉEN SITUÉ
À DAMPARIS (JURA - FRANCE)**



**2500 RÉFÉRENCES D'OUTILS POUR
L'INDUSTRIE ET L'AUTOMOBILE**

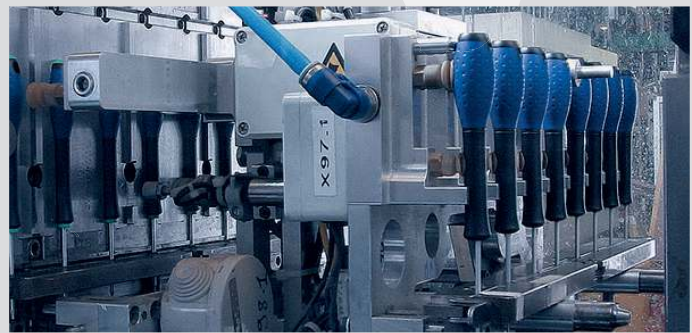

**DES SERVICES ESSENTIELS
SUR EXPERTBYFACOM.COM**

- Toutes les références accessibles dans la base de données produits
- Catalogue en ligne, brochures, notices d'utilisation
- Cartographie des points de vente pour retrouver votre revendeur le plus proche



EUROPE DE L'EST

Bulgarie
Hongrie
Pologne
Rép. Tchèque
Russie
Roumanie
Serbie
Slovénie

UNE MARQUE PROMUE PAR LES ÉQUIPES COMMERCIALES FACOM



GARANTIE EXPERT

S'applique à tous les outils de la gamme, sauf spécifications contraires, sans limitation de durée, contre tout vice de fabrication et défaut. Elle donnera lieu à un échange ou à une réparation des pièces défectueuses, sous conditions. Ne s'applique pas en cas d'utilisation non appropriée, modification des outils, mauvais entretien constaté. Le distributeur agréé EXPERT auquel sera remis le produit acceptera ou non l'application de la garantie selon ces conditions et après validation par le représentant ou le service technique EXPERT.



SOMMAIRE

RANGEMENT & SÉLECTION D'OUTILS P.6



CLÉS P.20



CLIQUETS - DOUILLES P.46



VISSAGE P.102



SERRAGE CONTRÔLÉ P.136



OUTILLAGE ÉNERGISÉ P.140



PINCES P.158



MESURAGE - TRAÇAGE P.170



FRAPPE P.176



COUPE P.184



ECLAIRAGE P.194



MAINTENANCE -TUBE - EXTRACTION P.202



ELECTRICITÉ - ELECTRONIQUE P.212



OUTILLAGE AUTOMOBILE P.226



SOLUTIONS DE DISTRIBUTION P.264



RANGEMENT ET SÉLECTION D'OUTILS





Servantes

P.8



Modules

P.11



Mobiliers d'atelier

P.13



Accessoires

P.14



Chariots d'atelier

P.14



Coffres

P.15



Boîtes à outils

P.16



Compositions multi-outils

P.18





SERVANTES

SERVANTE LARGE 7 TIROIRS - 4 MODULES PAR TIROIR

- 7 tiroirs : 4 de hauteur 60 mm et 3 de hauteur 130 mm.
- Chaque tiroir peut recevoir 4 modules.
- Ouverture des tiroirs à 100%.
- Charge par tiroir : 20 kg pour les tiroirs de 60 mm et 25 kg pour les tiroirs de 130 mm.
- Fermeture centralisée.
- Plan de travail recouvert d'une plaque ABS de 2 mm amovible – Résistance à une charge statique de 800 kg.
- Poignée polypropylène chargé fibre.
- Quatre roues de diamètre 125 mm, 2 fixes et 2 pivotantes, dont une avec frein.
- Dimensions hors tout (avec poignée) : L.1005 x P.500 x H.987 mm.
- Dimensions (sans poignée) : L.920 x P.500 x H.987 mm.
- Dimensions utiles des tiroirs : L.760 x P.420 mm.



LARGE

E010101	L mm	P mm	H mm	Poids kg		EAN
E010101	1005	500	987	95	1	3258950101019

SERVANTE LARGE 8 TIROIRS - 4 MODULES PAR TIROIR

- 8 tiroirs : 6 de hauteur 60 mm et 2 de hauteur 130 mm.
- Chaque tiroir peut recevoir 4 modules.
- Ouverture des tiroirs à 100%.
- Charge par tiroir : 20 kg pour les tiroirs de 60 mm et 25 kg pour les tiroirs de 130 mm.
- Fermeture centralisée.
- Plan de travail recouvert d'une plaque ABS de 2 mm amovible – Résistance à une charge statique de 800 kg.
- Poignée polypropylène chargé fibre.
- Quatre roues de diamètre 125 mm, 2 fixes et 2 pivotantes, dont une avec frein.
- Dimensions hors tout (avec poignée) : L.1005 x P.500 x H.987 mm.
- Dimensions (sans poignée) : L.920 x P.500 x H.987 mm.
- Dimensions utiles des tiroirs : L.760 x P.420 mm.



LARGE

E010131	L mm	P mm	H mm	Poids kg		EAN
E010131	1005	500	987	81,10	1	3258950101316



SERVANTES ET COFFRE MOBILE

SERVANTE 6 TIROIRS – 3 MODULES PAR TIROIR

- Servante 6 tiroirs : 3 tiroirs hauteur 60 mm. 2 tiroirs hauteur 130 mm. 1 tiroir d'une hauteur : 200 mm. Les tiroirs peuvent être équipés de tous les modules thermoformés ou mousse du programme EXPERT. 3 modules par tiroir. Charge maxi par tiroir : 20/25/30 kg.
- Plan de travail : Grand plan de travail en polypropylène chargé fibre (résistance à une charge statique de 700 kg), avec poignée intégrée et rebords évitant la chute d'outils en cours de déplacement. Résistance aux impacts et aux hydrocarbures. Emplacement dédié pour 3 tournevis et alvéoles pour visserie et petites pièces.
- Sécurité : Façade de tiroirs basculante en polypropylène avec crochets de sécurité. Pas de risque d'ouverture en cours de déplacement. Serrure positionnée sur le côté. Condamnation centralisée par serrure à clé, livrée avec 2 clés dont 1 articulée.
- Manoeuvrabilité : 4 roues diam. 125 mm, 2 pivotantes (dont une avec frein) et 2 fixes. Servante livrée avec les roues montées.
- Accessoires : Support flacons inclus (positionnable à droite ou à gauche).
- Dimensions, hors tout roues et plan de travail compris (L. x P. x H.) : 748 x 515 x 970 mm.
- Dimensions utiles des tiroirs (L. x P. x H.) : 569 x 421 x 60 / 130 / 200 mm.

E010192	L mm	P mm	H mm	Poids g	📦	EAN
E010192	748	515	970	54	1	3258950101927



SERVANTE 7 TIROIRS – 3 MODULES PAR TIROIR

- Servante 7 tiroirs : 4 tiroirs hauteur 60 mm. 3 tiroirs hauteur 130 mm. Les tiroirs peuvent être équipés de tous les modules thermoformé ou mousse du programme EXPERT. 3 modules par tiroir. Charge maxi par tiroir : 20/25 kg.
- Plan de travail : Grand plan de travail en polypropylène chargé fibre (résistance à une charge statique de 700kg), avec poignée intégrée et rebords évitant la chute d'outils en cours de déplacement. Résistance aux impacts et aux hydrocarbures. Emplacement dédié pour 3 tournevis et alvéoles pour visserie et petites pièces.
- Sécurité : Façade de tiroirs basculante en polypropylène avec crochets de sécurité. Pas de risque d'ouverture en cours de déplacement. Serrure positionnée sur le côté. Condamnation centralisée par serrure à clé, livrée avec 2 clés dont 1 articulée.
- Manoeuvrabilité : 4 roues diam. 125 mm, 2 pivotantes (dont une avec frein) et 2 fixes. Servante livrée avec les roues montées.
- Accessoires : Support flacons inclus (positionnable à droite ou à gauche).
- Dimensions, hors tout roues et plan de travail compris (L. x P. x H.) : 748 x 515 x 970 mm.
- Dimensions utiles des tiroirs (L. x P. x H.) : 569 x 421 x 60 / 130 / 200 mm.

E010193	L mm	P mm	H mm	📦	EAN
E010193	748	515	970	1	3258950101934





SERVANTES ET COFFRE MOBILE

SERVANTE 7 TIROIRS AVEC SOUTÈ – 3 MODULES PAR TIROIR

- Servante 7 tiroirs : 6 tiroirs hauteur 60 mm. 1 tiroir hauteur 270 mm. Les tiroirs peuvent être équipés de tous les modules thermoformés ou mousse du programme EXPERT. 3 modules par tiroir- Charge maxi par tiroir : 20/30 kg.
- Plan de travail : Grand plan de travail en polypropylène chargé fibre (résistance à une charge statique de 700 kg), avec poignée intégrée et rebords évitant la chute d'outils en cours de déplacement. Résistance aux impacts et aux hydrocarbures. Emplacement dédié pour 3 tournevis et alvéoles pour visserie et petites pièces
- Sécurité : Façade de tiroirs basculante en polypropylène avec crochets de sécurité. Pas de risque d'ouverture en cours de déplacement. Serrure positionnée sur le côté. Condamnation centralisée par serrure à clé, livrée avec 2 clés dont 1 articulée
- Manoeuvrabilité : 4 roues diam. 125 mm, 2 pivotantes (dont une avec frein) et 2 fixes. Servante livrée avec les roues montées.
- Accessoires : Support flacons inclus (positionnable à droite ou à gauche).
- Dimensions, hors roues et plan de travail compris (L. x P. x H.) : 748 x 515 x 970 mm.
- Dimensions utiles des tiroirs (L. x P. x H.) : 569 x 421 x 60 / 130 / 200 mm.



	L mm	P mm	H mm		EAN
E010194	748	515	970	1	3258950101941



LE SYSTÈME MODULAIRE EXPERT

Les boîtes et modules Expert ont été développés pour offrir un rangement facile et optimisé de vos outils dans les tiroirs des servantes.

Les servantes Expert acceptent 3 ou 4 modules, afin de répondre à vos besoins en termes de capacité de stockage d'outillage.

Dans un même tiroir vous pouvez stocker des modules et des boîtes, ouvertes ou fermées, sans aucune perte de place.

Tous vos outils seront ainsi disponibles et rangés dans un seul et même endroit, afin d'optimiser votre temps de travail.

Plus de détails sur les boîtes Expert pages 48-49.



Dimensions de modules standards : 185 x 240 cm.



Module : E194937

Plateau vide : E113557
Page : 25



Module : E110302

Plateau vide : E010508
Page : 25



Module : E111100

Plateau vide : E010509
Page : 33



Module : E194938

Plateau vide : E195064
Page : 33



Module : E111220

Plateau vide : E111221
Page : 35



Module : E111710

Plateau vide : E111711
Page : 38



Module : E034853

Plateau vide : E034854
Page : 50



Module : E030715

Plateau vide : E030716
Page : 57



Module : E194680

Plateau vide : E030701
Page : 57



Module : E194678

Plateau vide :
Page : 67



Module : E031821

Plateau vide : E031822
Page : 67



Module : E032922

Plateau vide : E032923
Page : 81





RANGEMENT ET SÉLECTION D'OUTILS



Module : E194677
Plateau vide : E032901
Page : 81



Module : E032201
Plateau vide : E010515
Page : 81



Module : E032924
Plateau vide : E032925
Page : 81



Module : E231101
Plateau vide : E231105
Page : 149



Module : E041604
Plateau vide : E041606
Page : 150



Module : E040601
Plateau vide : E040602
Page : 150



Module : E041644
Plateau vide : E041645
Page : 150



Plateau vide : E010516



Module : E194940
Plateau vide : E160916
Page : 106



Module : E194941
Plateau vide : E160917
Page : 107



Module : E121609
Plateau vide : E121205
Page : 123



Module : E121706
Plateau vide : E121214
Page : 125



Module : E121105
Plateau vide : E121106
Page : 127



Plateau vide : E131704



Module : E080821
Plateau vide : E010537
Page : 161



Module : E080801
Plateau vide : E010504
Page : 161



Module : E194944
Plateau vide : E010504
Page : 161



Module : E194943
Plateau vide : E010503
Page : 166



Module : E150801
Plateau vide : E010501
Page : 178



Module : E150802
Plateau vide : E010506
Page : 178



Module : E150803
Plateau vide : E010507
Page : 178



Module : E090302
Plateau vide : E010519
Page : 172



Module : E142401
Plateau vide : E142402
Page : 172



Module : E020611
Plateau vide : E010514
Page : 187



MOBILIERS D'ATELIER

ETABLIS BOIS

- Longueur du plan de travail : 2 m.
- Plan de travail en bois (épaisseur 28 mm).
- Résistance statique : 800 kg.
- Hauteur : 850 mm.
- Possibilité d'ajouter deux tiroirs (E010405).



E010402	Poids kg	📦	EAN
E010402	76	1	3258950104027

ETABLIS MÉTAL

- Longueur du plan de travail : 2 m.
- Plan de travail en métal (épaisseur 2 mm).
- Résistance statique : 800 kg.
- Hauteur : 850 mm.
- Possibilité d'ajouter deux tiroirs (E010405).



E010404	Poids kg	📦	EAN
E010404	77	1	3258950104041

TIROIR POUR ÉTABLI

- Verrouillage par serrure à clef.
- Tiroir pour établis : E010402 - E010404.
- Dimensions : 570 x 420 x 175 mm.



E010405	Poids kg	📦	EAN
E010405	4	1	3258950104058





MOBILIERS D'ATELIER

PLATEAUX MAGNÉTIQUES EXTENSIBLES

- Fond aimanté pour un maintien efficace de la visserie, boulonnerie et autres petites pièces métalliques.
- Peut être utilisé horizontalement ou verticalement.
- Capacité extensible en fonction des besoins.
- Rétractable, peut se ranger dans un tiroir de servante.
- E010128 - hauteur : de 35 à 92 mm ; diamètre 135 mm.
- E010129 - hauteur : de 42 à 130 mm ; diamètre 225 mm.



	Poids g	☒	EAN
E010128	132	1	3258950101286
E010129	510	1	3258950101293

CHARIOTS D'ATELIER

CHARIOT D'ATELIER ALUMINIUM ET PLASTIQUE

- Construction en plastique et aluminium.
- 4 roues pivotantes, dont 2 avec frein pour un déplacement et une manutention aisés.
- Charge maximum : 150 kg.



	L mm	P mm	H mm	Poids kg	☒	EAN
E010136	752	470	965	11,5	1	3258950101361



SERVANTE D'ATELIER ROULANTE

- Poignée de manœuvre confortable.
- Plan de travail et étagères avec rebords évitant la chute des outils et équipés de tapis antidérapants en caoutchouc.
- 2 roues pivotantes et 2 fixes Ø 80 mm pour un déplacement et une manutention aisés.
- Charge maximum : 200 Kg.



	L mm	P mm	H mm	Poids kg	📦	EAN
E010108	925	495	120	22,3	1	3258950101088

COFFRES

COFFRES DE CHANTIER

- Fabriqué en épaisse tôle d'acier.
- Équipé de charnières à axe condamné, le couvercle s'ouvre à 95°.
- Équipé de 2 poignées latérales pour le transport.
- Livré avec un plateau amovible en tôle.
- Verrouillable par cadenas (non livré).
- Fixable au sol : 4 trous au fond du coffre.



	L mm	P mm	H mm	Poids kg	📦	EAN
E010209	520	290	294	7	1	3258950102092
E010202	650	366	353	11,50	1	3258954102029
E010203	850	360	353	12,10	1	3258953102037
E010204	1000	405	450	16,60	1	3258954102043





BOÎTES À OUTILS

BOÎTES MÉTALLIQUES 5 CASES

- 2 poignées articulées.
- 5 compartiments sur 3 niveaux.
- Verrouillable par cadenas (non livré).
- Facilité d'ouverture.
- Dimensions (avec poignée) boîte 450 mm :
L.490 x P.250 x H.230 mm - boîte 535 mm :
L.575 x P.250 x H.230 mm.
- Soute dimensions intérieures boîte 450 mm :
L.448 x P.200 x H.98 mm - boîte 535 mm :
L.518 x P.200 x H.98 mm.
- Casiers dimensions intérieures boîte 450 mm :
L.448 x P.100 x H.55 mm - boîte 535 mm :
L.526 x P.100 x H.55 mm.



	L mm	P mm	H mm	Poids kg		EAN
E194738	450	250	230	4	1	3258951947388
E010201	535	250	230	5,20	1	3258950102016

BOÎTES PLASTIQUE

- Couvercle équipé de 3 compartiments de rangement transparents, dont 2 amovibles.
- Plateau amovible.
- 2 fermetures métalliques.
- Verrouillable par cadenas (non livré).
- Poignée escamotable.
- Capacité de charge boîte 410 mm :
8 kg - boîte 490 mm : 10 kg.



	L mm	P mm	H mm	Poids g		EAN
E010304	410	255	182	1250	1	3258950103044
E010305	490	285	240	1682	1	3258950103051



BOITE À OUTIL TEXTILE

- Poches élastiques à l'intérieur et à l'extérieur du sac offrant de multiples possibilités de rangement.
- Rangement ajustable pour scie.
- 2 poches latérales, une avec rabat, une avec sangle ajustable.
- Capote repliable dans une poche.
- Poignée en acier robuste avec zone de préhension confort.
- Sangle réglable avec protection d'épaule.
- Tissus 600 x 600 deniers.
- Soute rigide et étanche.
- Capacité de charge : 10 kg.



	L mm	P mm	H mm	Poids kg		EAN
E010601	465	215	310	2,57	1	3258950106014

SAC À DOS À ROULETTES

- Idéal pour la maintenance itinérante.
- Poches intérieures et extérieures du sac offrant de multiples possibilités de rangement.
- Anses rembourrées et ajustables
- Poignée de transport sur le haut.
- Compartiment pour ranger les anses afin qu'elles ne traînent pas sur le sol.
- Manche télescopique et roulettes
- Tissus 600 x 600 deniers.
- Soute rigide et étanche.
- Capacité de charge : 10 kg.



	L mm	P mm	H mm	Poids kg		EAN
E010602	338	218	470	3,68	1	3258950106021





COMPOSITION MULTI-OUTILS

VALISE DE MAINTENANCE 96 OUTILS

- Clés mixtes 8 - 10 - 11 - 12 - 13 - 14 - 16 - 17 - 18 - 19 mm.
- 1 clé à molette 250 mm.
- 1/4" : - Douilles 4 - 5 - 5,5 - 6 - 7 - 8 - 9 - 10 - 11 - 12 - 13 mm - 1 cliquet - cardan.
- 1 poignée coulissante - 2 rallonges 55-100 mm - 1 douille porte-embouts 1/4"
- 1 poignée emmanchée.
- 1/2" : - Douilles 10 - 11 - 12 - 13 - 14 - 15 - 16 - 17 - 18 - 19 - 22 mm
- 1 cliquet - cardan - 2 rallonges 75-250 mm.
- Tournevis : Fente 3,5 x 75 - 4 x 100 - 6,5 x 150 - 8 x 175. Phillips® PH 1-2
- Pozidriv® PZ 1-2.
- Coffret de vissage 19 pièces.
- Jeu de 9 clés mâles 6 pans.
- Jeu de 7 clés mâles Torx®.
- 1 pince becs 1/2 ronds longs.
- 1 pince coupante diagonale.
- 1 pince multiprise.
- 1 marteau rivoir 32 mm.
- 1 chasse-goupilles 4 - 6 mm.
- 1 pointeau 4 mm.
- 1 monture de scie.
- 1 mètre ruban 5 m.



	Poids kg		EAN
E220104	8,6	1	3258952201045

VALISE DE MAINTENANCE 142 OUTILS

- Clés mixtes 8 - 9 - 10 - 11 - 12 - 13 - 14 - 16 - 17 - 18 - 19 mm.
- 1 clé à molette 250 mm.
- 1/4" : - Douilles 4 - 5 - 5,5 - 6 - 7 - 8 - 9 - 10 - 11 - 12 - 13 mm. - 1 cliquet - cardan.
- 2 rallonges 55 - 100 mm. - 1 douille porte-embouts 1/4". - 1 poignée emmanchée.
- 1/2" : - Douilles 10 - 11 - 12 - 13 - 14 - 15 - 16 - 17 - 18 - 19 - 20 - 22 - 24 - 27 -
30 - 32 mm. - Cliquet - cardan. - Rallonges 75-250 mm.
- Tournevis : Fente 2,5 x 50 - 3,5 x 75 - 4 x 100 - 5,5 x 125 - 6,5 x 150 - 8 x 175
- Phillips® PH 1-2 - Pozidriv® PZ 1-2.
- 1 tournevis testeur.
- 1 coffret de vissage 49 pièces.
- 1 Jeu de 9 clés mâles 6 pans.
- 1 Jeu de 7 clés mâles Torx®.
- 1 pince becs 1/2 ronds longs.
- 1 pince universelle.
- 1 pince coupante diagonale.
- 1 pince multiprise - Pince à dénuder.
- 1 pince à sertir pour cosses.
- 1 tenaille russe 250 mm.



	Poids kg		EAN
E220107	13,6	1	3258952201076



COMPOSITION MULTI-OUTILS - 124 PIÈCES

- Douilles 6 pans 1/4" : 4-4,5-5-5,5-6-7-8-9-10-11-12-13-14 mm.
- 2 cliquets parcmètre à verrouillage 1/4" et 1/2".
- 2 rallonges 1/4" : 55-100 mm et 2 rallonges 1/2" : 130-250 mm.
- 2 cardans 1/4" et 1/2".
- 1 adaptateur 1/4" pour embouts 1/4".
- 1 poignée emmanchée 1/4".
- 1 pince multiprise entrecroisée 250 mm.
- 1 pince coupante diagonale mécanicien 160 mm.
- 1 pince à becs 1/2" ronds - coudés 40°.
- Douilles 6 pans 1/2" : 10-11-12-13-14-15-16-17-18-19-21-22-24-27-30-32 mm.
- Clés mixtes : 8-10-11-12-13-14-15-16-17-18-19 mm.
- Jeu de 9 clés mâles courtes sur étui : 1,5-2-2,5-3-4-5-6-8-10 mm.
- Jeu de 7 clés mâles Torx® sur étui : T10-T15-T20-T25-T27-T30-T40 mm.
- Tournevis : - fente : 4x100-6,5x125 - Phillips® : PH1x100-PH2x125 - Pozidriv® : PZ1x100-PZ2x125.
- Boîte de 48 embouts et 1 accessoire : - fente : 4-4,5-5-5,5-6-6,5x2-8 mm - Phillips® : PH1x2-PH2x3-PH3 - Pozidriv® : PZ1x2-PZ2x3-PZ3x2 - Torx® : T10x2-T15x2-T20x2-T25x2-T30x2 - ResisTorx® : TT10-TT15x2-TT20x2-TT25x2-TT30x2-TT40 - 6 pans : 2-3x2-4x2-5x2-6x2 mm.
- 1 porte-embouts magnétique à bague de verrouillage.



	Dimension mm	Poids kg	☒	EAN
E034806	L.565 x P.415 x H.92	8,30	1	3258950348063

COMPOSITION MULTI OUTILS - 126 PIÈCES

- Douilles 6 pans 1/4" métriques : 4-4,5-5-5,5-6-7-8-9-10-11-12-13-14 mm.
- Douilles longues 6 pans 1/4" métriques : 4-5-5,5-6-7-8-9-10-11-12-13-14 mm.
- Douilles 6 pans 1/4" en pouces : 3/16"-7/32"-1/4"-9/32"-5/16"-11/32"-3/8"-7/16"-1/2"-9/16".
- Douilles longues 6 pans 1/4" en pouces : 3/16"-7/32"-1/4"-9/32"-5/16"-11/32"-3/8"-7/16"-1/2"-9/16".
- Douilles 6 pans 3/8" métriques : 10-11-12-13-14-15-16-17-18-19 mm.
- Douilles longues 6 pans 3/8" métriques : 10-11-12-13-14-15-16-17-18-19 mm.
- Douilles 6 pans 3/8" en pouces : 1/4"-5/16"-11/32"-3/8"-7/16"-1/2"-9/16"-5/8"-11/16"-3/4"-13/16"-7/8"-15/16"-1".
- Douilles longues 6 pans 3/8" en pouces : 1/4"-5/16"-3/8"-7/16"-1/2"-9/16"-5/8"-11/16"-3/4"-13/16"-7/8"-15/16"-1".
- Clés mixtes métriques : 10-11-12-13-14-15-16-17-18-19 mm.
- Clés mixtes en pouces : 5/16"-11/32"-3/8"-7/16"-1/2"-9/16"-5/8"-11/16"-3/4".
- 2 cliquets parcmètre à verrouillage 1/4" et 3/8".
- 2 rallonges 1/4" : 55-150 mm et 1 Rallonge 3/8" : 125 mm.
- 2 cardans 1/4" et 3/8".
- Augmentateur 1/4" - 3/8".
- Réducteur 3/8" - 1/4".
- Tournevis : - fente : 3x50 - 4x100 - 5,5x125. - Phillips® : PH0x75 - PH1x100 - PH2x125.



	Dimension mm	Poids kg	☒	EAN
E034835	L.565 x P.415 x H.92	9,7	1	3258950348353



CLÉS





Clés mixtes

P.22



Clés mixtes à cliquet

P.28



Clés polygonales à cliquet

P.32



Clés à cliquet 4 en 1

P.32



Modules de clés à cliquet

P.33



Clés à fourches

P.34



Clés à fourches DIN

P.36



Clés polygonales contrecoudées

P.37



Clés à pipe

P.39



Clés en tube

P.40



Clés à tuyauter

P.42



Clés à molette

P.43



Clés à ergots

P.45



Clés à échafaudage

P.45



**CLÉS MIXTES****CLÉS MIXTES - MM**

→ ISO 691 - ISO 1711-1 - ISO 3318 - ISO 7738 - DIN 3113

→ Tête polygonale 12 pans soudée à 15°.

→ Fourche orientée à 15° par rapport à l'axe du manche (angle de reprise 30°).

→ Profil de l'œil maximisant la surface de contact avec l'écrou pour une longévité accrue.

→ Forgées à partir d'acier au Chrome Vanadium.

→ Finition : chromée, brillante.

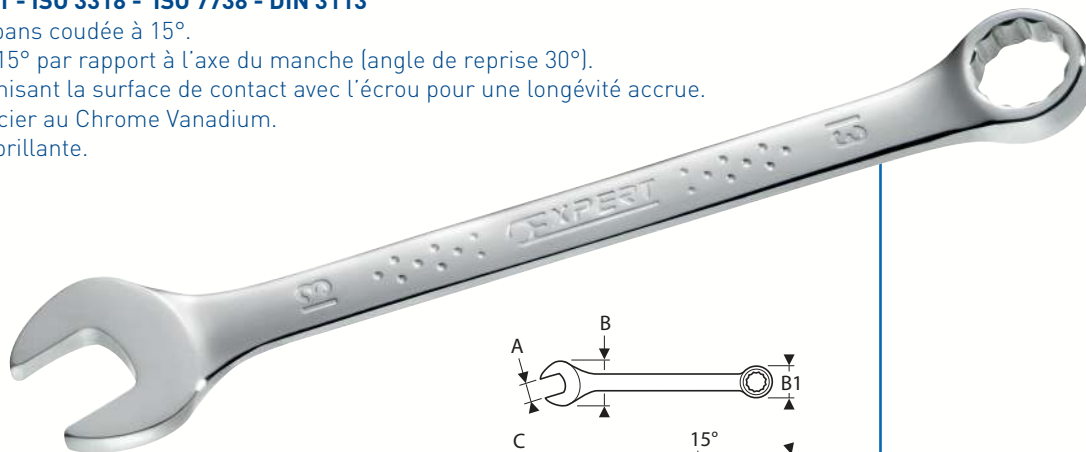

	A mm	B mm	B1 mm	C mm	C1 mm	L mm	Poids g	☒	EAN
E113228	5	14.7	9	3.4	4	93	15	1	3258951132289
E113229	5,5	14.7	9	3.4	4	93	15	1	3258951132296
E113202	6	16.2	10.4	3.7	4.5	100	20	1	3258951132029
E113200	7	18.2	11.7	3.7	5	110	20	1	3258951132005
E113201	8	20.2	13.2	4	5	120	25	1	3258951132012
E113204	9	22.2	14.6	4	6	130	35	1	3258951132043
E113205	10	23.7	16	4	6.5	140	37	1	3258951132050
E113206	11	25.7	17	4.7	6.5	150	45	1	3258951132067
E113207	12	27.5	19	4.8	7	160	60	1	3258951132074
E113208	13	28.7	20.6	5.5	7.5	170	67	1	3258951132081
E113209	14	31.7	22	5.6	8	180	80	1	3258951132098
E113210	15	34	23.4	5.7	8.5	190	95	1	3258951132104
E113211	16	36	24.8	5.8	9	200	110	1	3258951132111
E113212	17	38.5	26.2	6.3	9.5	210	123	1	3258951132128
E113213	18	39	27.6	6.8	10	220	150	1	3258951132135
E113214	19	42.2	29	7.1	10.4	230	165	1	3258951132142
E113215	20	42.7	30.2	7.2	10.9	240	180	1	3258951132159
E113216	21	45.5	31.7	7.5	11.4	250	185	1	3258951132166
E113217	22	48.7	33	8	11.9	260	242	1	3258951132173
E113218	23	48.7	33	8	11.9	260	235	1	3258951132180
E113219	24	50.7	35	8	12.9	280	280	1	3258951132197
E113220	25	52.7	38	8	13.4	295	325	1	3258951132203
E113221	26	52.7	38	8	13.4	295	325	1	3258951132210
E113222	27	56.2	40	8.9	14.4	310	370	1	3258951132227
E113223	28	60.2	44.6	9	15.9	340	495	1	3258951132234
E113224	29	60.2	44.6	9	15.9	340	495	1	3258951132241
E113225	30	60.2	44.6	9	15.9	340	485	1	3258951132258
E113226	32	64.7	47.3	10.6	16	360	600	1	3258951132265
E110101	34	68.7	49.3	11.5	17.2	380	639	1	3258951101018
E110102	36	73	53.4	13	18.2	410	809	1	3258951101025
E110103	38	76	56.5	14.5	19	430	965	1	3258951101032



CLÉS MIXTES - POUCES

→ ASME B 107-100

- Tête polygonale 12 pans coudée à 15°.
- Fourche orientée à 15° par rapport à l'axe du manche (angle de reprise 30°).
- Profil de l'œil maximisant la surface de contact avec l'écrou pour une longévité accrue.
- Forgées à partir d'acier au Chrome Vanadium.
- Finition : chromée, brillante.

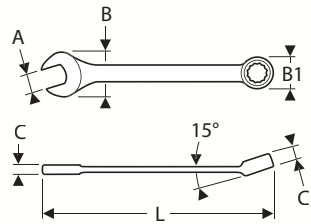
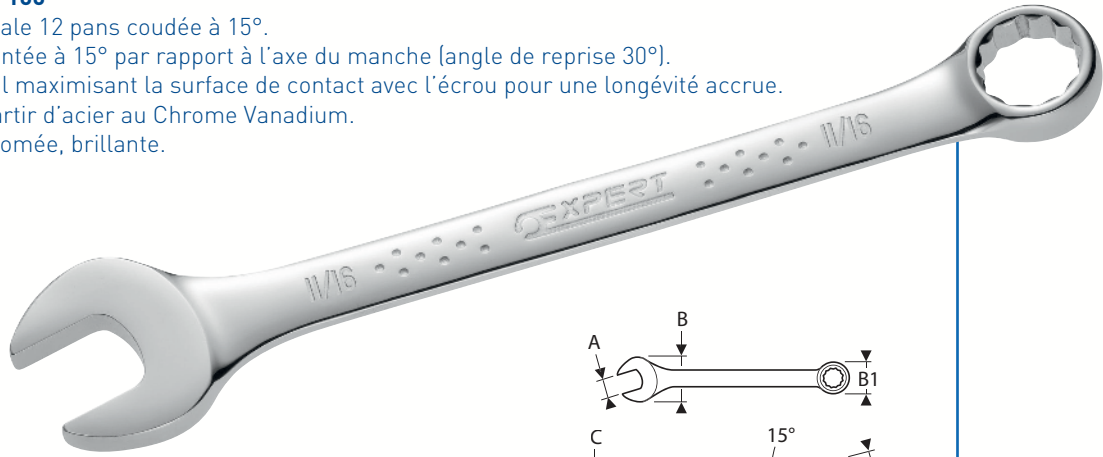

	A "	B mm	B1 mm	C mm	C1 mm	L mm	Poids g	☒	EAN
E113312	1/4"	16.2	10.4	3.7	4.5	100	15	1	3258951133125
E113230	5/16"	20.2	13.2	4	5	120	26	1	3258951132302
E113313	11/32"	22.2	14.6	4	6	130	30	1	3258951133132
E113314	3/8"	23.7	16	4	6.5	140	38	1	3258951133149
E113315	7/16"	25.7	17	4.7	6.5	150	46	1	3258951133156
E113316	1/2"	28.7	20.6	5.5	7.5	170	68	1	3258951133163
E113317	9/16"	31.7	22	5.6	8	180	79	1	3258951133170
E113318	5/8"	36	24.8	5.8	9	200	110	1	3258951133187
E113358	3/4"	42.2	29	7.1	10.4	230	150	1	3258951133583
E113359	13/16"	45.5	31.7	7.5	11.4	250	194	1	3258951133590
E113360	7/8"	48.7	33	8	11.9	260	225	1	3258951133606
E113235	15/16"	50.7	35	8	12.9	280	293	1	3258951132357
E113236	1"	52.7	38	8	13.4	295	328	1	3258951132364
E113319	11/16"	38.5	26.2	6.3	9.5	210	141	1	3258951133194
E113361	1 1/16	56.2	40	8.9	14.4	310	386	1	3258951133613
E113362	1 1/8	60.2	44.6	9	15.9	340	503	1	3258951133620
E113363	1 1/4	64.7	47.3	10.6	16	360	602	1	3258951133637
E110201	1 5/16	68.7	49.3	11.5	17.2	380	632	1	3258951102015
E110202	1 3/8	73	53.4	13	18.2	410	806	1	3258951102022
E110203	1 7/16	73	53.4	13	18.2	410	804	1	3258951102039
E110204	1 1/2	76	56.5	14.5	19	430	992	1	3258951102046
E110205	1 5/8	83.5	61.5	15.5	20	480	1264	1	3258951102053
E110206	1 7/8	101.5	73.5	17.2	22.6	540	2110	1	3258951102060





CLÉS MIXTES

JEUX DE CLÉS MIXTES



	Contenu	Contenant	Quantité	Poids g		EAN
E110300	8-10-11-13-17-19-22-24 mm.	Boîte carton	8	1122	1	3258951103005
E113241	1/4"-5/16"-3/8"-7/16"-1/2"-9/16"-5/8"-11/16"-3/4	Boîte carton	9	851	1	3258951132418
E110310	10-11-12-13-14-15-16-17-18-19 mm.	Rack plastique	10	1080	1	3258951103104
E110309	7-8-10-11-12-13-16-17-18-19-22-24 mm.	Rack plastique	12	1495	1	3258951103098
E110327	7-8-10-11-12-13-16-17-18-19-22-24 mm.	Trousse	12	1495	1	3258951103272
E113242	1/4"-5/16"-3/8"-7/16"-1/2"-9/16"-5/8"-11/16"-3/4"-13/16"-7/8"-15/16	Boîte carton	12	1580	1	3258951132425
E113238	8-9-10-11-12-13-14-15-16-17-18-19-20-21-22-24 mm.	Boîte plastique	16	1894	1	3258951132388
E113239	6-7-8-9-10-11-12-13-14-15-16-17-18-19-22-24 mm.	Boîte carton	16	1646	1	3258951132395
E110313	6-7-8-9-10-11-12-13-14-15-16-17-18-19-20-21-22-24 mm.	Trousse	18	2035	1	3258951103135
E113240	6-7-8-9-10-11-12-13-14-15-16-17-18-19-20-21-22-24 mm.	Boîte carton	18	2022	1	3258951132401
E110306	6-7-8-9-10-11-12-13-14-15-16-17-18-19-20-21-22-24-27-30-32 mm.	Boîte carton	21	3450	1	3258951103067
E110326	6-7-8-9-10-11-12-13-14-15-16-17-18-19-20-21-22-24-26-27-30-32 mm.	Trousse	22	3998	1	3258951103265
E110323	6-7-8-9-10-11-12-13-14-15-16-17-18-19-20-21-22-23-24-25-26-27-28-29-30-32 mm.	Boîte carton	26	4600	1	3258951103234



MODULES DE CLÉS MIXTES

- Plateau thermoformé.
- Conçus pour s'insérer dans les tiroirs de servante.
- Plateau vide pour module E194937 : E113557.
- Plateau vide pour module E110302 : E010508.



	Contenu	Quantité	Poids g	📦	EAN
E110302	27-29-30-32 mm.	4	2230	1	3258951103029
E194937	6-7-8-9-10-11-12-13-14-15-16-17-18-19-22-24 mm.	16	1850	1	3258951949375

JEU DE 7 CLÉS MIXTES COURTES - MM

- Livré sur rack plastique.



	Contenu	Quantité	Poids g	📦	EAN
E110304	10-12-13-14-15-17-19 mm.	7	640	1	3258951103043





CLÉS MIXTES

CLÉS MIXTES LONGUES - MM

- ISO 691 - ISO 1711-1
- Angle de reprise 5°.
- Tête polygonale 12 pans coudée à 15°.
- Fourche orientée à 15° par rapport à l'axe du manche (angle de reprise 30°).
- Profil de l'œil maximisant la surface de contact avec l'écrou pour une longévité accrue.
- Forgées à partir d'acier au Chrome Vanadium.
- Clés allongées pour une puissance de serrage accrue.
- Finition : chromée, brillante.

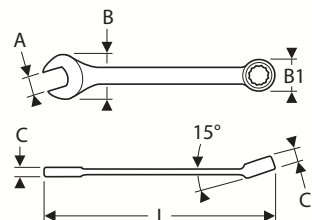
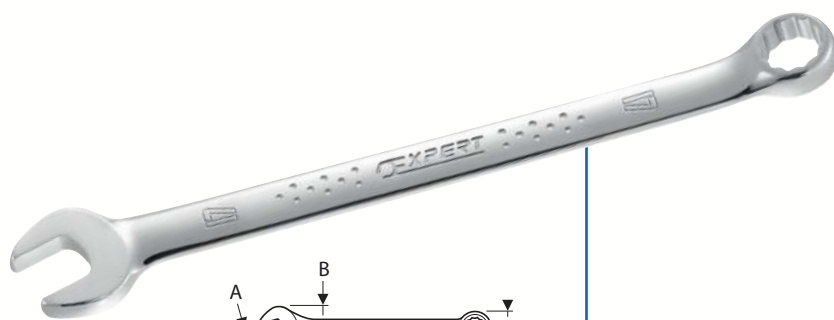

	A mm	B mm	B1 mm	C mm	C1 mm	L mm	Poids g	☒	EAN
E110701	8	17.7	13.3	4.2	6.4	148	35	1	3258951107010
E110702	9	20.5	14.8	5	7.1	167	45	1	3258951107027
E110703	10	21.8	16	5.4	7.4	172	50	1	3258951107034
E110704	11	24.2	17.3	5.5	8	186	60	1	3258951107041
E110705	12	26.5	18.5	5.7	8.4	197	75	1	3258951107058
E110706	13	27.4	19.7	6.1	8	207	85	1	3258951107065
E110707	14	30.7	22.1	6.7	9	223	100	1	3258951107072
E110708	15	32	23.1	7	9.9	233	120	1	3258951107089
E110709	16	34.5	24.1	7.3	10.6	243	140	1	3258951107096
E110710	17	37	26.4	8.1	11.2	261	155	1	3258951107102
E110711	18	39.1	27.5	8.4	11.4	270	190	1	3258951107119
E117701	21	44.8	32.4	9	13.1	301	312	1	3258951177013
E117702	22	47.3	33.4	9.5	13.7	318	347	1	3258951177020
E117703	23	47.3	33.4	9.5	13.7	318	349	1	3258951177037
E117704	24	51.6	35.4	10.1	14.9	338	436	1	3258951177044
E117705	26	54.5	37	10.4	15.7	355	527	1	3258951177051
E117706	27	55.6	40.4	11.4	17	375	576	1	3258951177068
E117707	28	55.6	40.4	11.4	17	375	591	1	3258951177075
E117708	29	58.6	42.3	12.4	18.2	414	727	1	3258951177082
E117709	30	58.6	42.3	12.4	18.2	414	720	1	3258951177099
E117710	32	65.5	46.8	13.4	19	435	869	1	3258951177105
E117711	33	70.2	49.7	13.4	17.5	470	1092	1	3258951177112
E117712	34	70.2	49.7	13.4	17.5	470	1079	1	3258951177129
E117713	35	70.2	49.7	13.4	17	470	1150	1	3258951177136
E117714	36	75.2	55.5	14.3	18.2	510	1303	1	3258951177143
E117715	38	75.2	55.5	14.3	18.2	510	1255	1	3258951177150
E117716	41	82	59.6	15	18	550	1567	1	3258951177167
E117717	42	82	59.6	15	18	550	1662	1	3258951177174
E117718	46	85	63.6	17.2	19	612	1763	1	3258951177181
E117719	50	95	72	19.3	22.2	650	2600	1	3258951177198

JEU DE 12 CLÉS MIXTES LONGUES - MM

- Livré sur rack plastique.

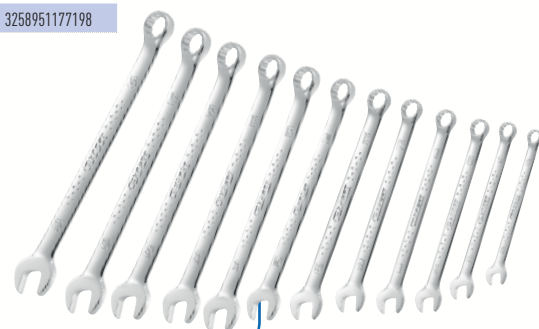

	Contenu	Quantité	Poids g	☒	EAN
E110303	8-9-10-11-12-13-14-15-16-17-18-19 mm.	12	1690	1	3258951103036



CLÉS MIXTES CONTRECOURDÉES - MM

→ ISO 691 - ISO 1711-1 - ISO 3318 - ISO 7738 - DIN 3113

→ Tête polygonale 12 pans contrecoudée à 70°.

→ Fourche orientée à 15° par rapport à l'axe du manche (angle de reprise 30°).

→ Profil de l'œil maximisant la surface de contact avec l'écrou pour une longévité accrue.

→ Forgées à partir d'acier au Chrome Vanadium.

→ Finition : chromée, brillante.

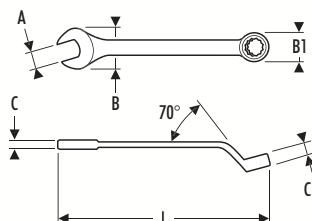
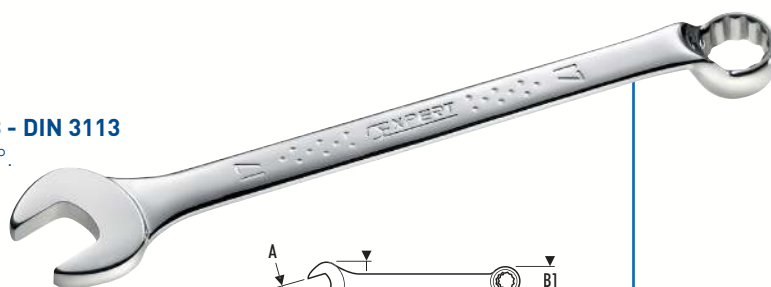

	A mm	B mm	B1 mm	C mm	C1 mm	L mm	Poids g	📦	EAN
E117720	6	16.3	10.4	3.7	5.2	125	17	1	3258951177204
E117721	7	18.2	11.8	3.7	5.7	135	21	1	3258951177211
E117722	8	20.3	13.4	4	6.3	145	32	1	3258951177228
E117723	9	22.2	14.4	4	7.3	155	41	1	3258951177235
E117724	10	23.8	16.2	4	7.3	165	44	1	3258951177242
E117725	11	25.7	17.2	4	8.1	172	56	1	3258951177259
E117726	12	27.6	18.7	4	8	180	67	1	3258951177266
E117727	13	28.8	20.3	5.9	9.6	195	77	1	3258951177273
E117728	14	31.7	21.5	5.9	9	210	89	1	3258951177280
E117729	15	34	22.8	6.4	10	215	107	1	3258951177297
E117730	16	36	24.2	6.8	10.9	230	132	1	3258951177303
E117731	17	38.6	26.1	7.1	11.6	240	150	1	3258951177310
E117732	18	39	27.2	7.4	12.2	255	167	1	3258951177327
E117733	19	42.1	28.8	7.8	12.5	265	191	1	3258951177334
E117734	21	45.3	31.7	8.4	12.8	280	240	1	3258951177341
E117735	22	46.1	33	8.6	13.1	300	276	1	3258951177358
E117736	23	51.4	35	9	14	320	347	1	3258951177365
E117737	24	51.4	35	9	14	320	337	1	3258951177372
E117738	26	54.5	38	10.4	15.3	348	448	1	3258951177389
E117739	27	57.8	41	10.8	16	370	569	1	3258951177396
E117740	28	57.8	41	10.8	16	370	553	1	3258951177402
E117741	29	62.5	43.7	11.4	16.5	390	664	1	3258951177419
E117742	30	62.5	43.7	11.4	16.5	390	651	1	3258951177426
E117743	32	67	46.7	12	17.5	412	813	1	3258951177433

JEU DE 9 CLÉS MIXTES CONTRECOURDÉES - MM

→ Livré en boîte carton.



E117744	Contenu	Poids g	📦	EAN
E117744	8-9-10-11-13-14-15-17-19 mm	840	1	3258951177440





CLÉS MIXTES À CLIQUET

CLÉS MIXTES À CLIQUET - MM

- ISO 691 - ISO 1711-1
- Angle de reprise 5°.
- Tête polygonale à cliquet 12 pans coudée à 15°.
- Changement de sens par inverseur encastré et protégé.
- Fourche orientée à 15° par rapport à l'axe du manche (angle de reprise 30°).
- Profil de l'œil maximisant la surface de contact avec l'écrou pour une longévité accrue.
- Forgées à partir d'acier au Chrome Vanadium.
- Finition : chromée, brillante.

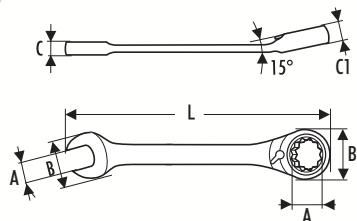
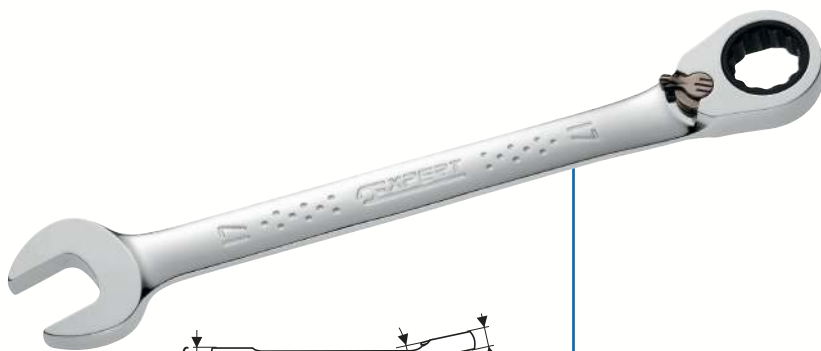

	A mm	B mm	B1 mm	C mm	C1 mm	L mm	Poids g		EAN
E117377	6	16.3	17.7	5	7.7	124	28	1	3258951173770
E117378	7	16.3	17.7	5	7.7	124	28	1	3258951173787
E113301	8	18.5	17.7	5	7.7	135	32	1	3258951133019
E113302	9	20.5	19	5.3	7.7	142	40	1	3258951133026
E113303	10	22.5	21.2	5.8	8	158	56	1	3258951133033
E113300	11	25	22.6	5.9	8	167	68	1	3258951133002
E113304	12	26.9	23.8	6.1	8	173	78	1	3258951133040
E113305	13	29	25.9	6.6	8.9	179	96	1	3258951133057
E113306	14	31.5	27.7	7.5	9	189	116	1	3258951133064
E113307	15	34	29.2	7.9	9.4	199	136	1	3258951133071
E113308	16	35	31.8	7.9	9.9	215	160	1	3258951133088
E113309	17	38	34.1	8	10.6	232	182	1	3258951133095
E113310	18	40.1	34	8.5	11	238	200	1	3258951133101
E113311	19	42	35.1	8.9	11.2	247	248	1	3258951133118
E117370	21	45.3	41.5	10.3	13	285	540	1	3258951173701
E117371	22	45.3	41.5	10.3	13	285	540	1	3258951173718
E117372	24	52	47	10.8	14.5	325	710	1	3258951173725
E117373	27	58.6	52	12.5	15	359	750	1	3258951173732
E117374	30	64.5	59.5	13	17	425	970	1	3258951173749
E113460	32	64.5	59.5	13	17	425	970	1	3258951134603

JEUX DE CLÉS MIXTES À CLIQUET - MM



	Contenu	Contenant	Quantité	Poids g		EAN
E111107	8-10-12-13-14-17-19 mm.	Rack plastique	7	990	1	3258951111079
E111106	8-9-10-11-12-13-14-15-16-17-18-19 mm.	Rack plastique	12	1670	1	3258951111062



CLÉS MIXTES À CLIQUET RAPIDES - MM

- ISO 691 - ISO 1711-1
- Angle de reprise 5°.
- Tête polygonale 12 pans droite.
- Changement de sens par retournement de la clé.
- Tête à fourche à effet cliquet orientée à 15°.
- Profil de l'œil maximisant la surface de contact avec l'écrou pour une longévité accrue.
- Forgées à partir d'acier au Chrome Vanadium.
- Finition : chromée, brillante.

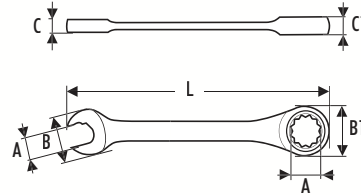
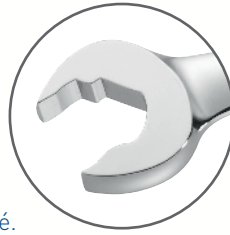

	A mm	B mm	B1 mm	C mm	C1 mm	L mm	Poids g	☒	EAN
E110924	8	18	17.5	5	7	136	30	1	3258951109243
E110925	9	20	19.3	5.4	7.6	143	45	1	3258951109250
E110926	10	22	21	5.8	7.7	160	55	1	3258951109267
E110927	11	24.5	22.7	6.1	8	168	65	1	3258951109274
E110928	12	26.5	24	6.4	8	174	75	1	3258951109281
E110929	13	27.6	26	6.7	9	180	105	1	3258951109298
E110930	14	31.4	27.7	7.4	9.4	193	115	1	3258951109304
E110931	15	33.4	29	7.7	10	200	140	1	3258951109311
E110932	16	34.6	30.7	8.1	10.6	216	165	1	3258951109328
E110933	17	38.4	33	8	10.9	233	185	1	3258951109335
E110934	18	39.9	33	9	11.2	239	205	1	3258951109342
E110935	19	41.5	34	9.5	11.5	250	225	1	3258951109359

JEU DE 12 CLÉS MIXTES À CLIQUET RAPIDES - MM

- Livré sur rack plastique.



	Contenu	Quantité	Poids g	☒	EAN
E111101	8-9-10-11-12-13-14-15-16-17-18-19 mm.	12	1590	1	3258951111017





CLÉS MIXTES À CLIQUET

CLÉS MIXTES À CLIQUET ARTICULÉES - MM

- ISO 691 - ISO 1711-1
- Angle de reprise 5°.
- Tête polygonale 12 pans articulée à 180°.
- Changement de sens par retournement de la clé.
- Fourche orientée à 15° par rapport à l'axe du manche (angle de reprise 30°).
- Profil de l'œil maximisant la surface de contact avec l'écrou pour une longévité accrue.
- Forgées à partir d'acier au Chrome Vanadium.
- Finition : chromée, brillante.

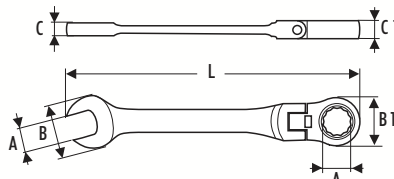
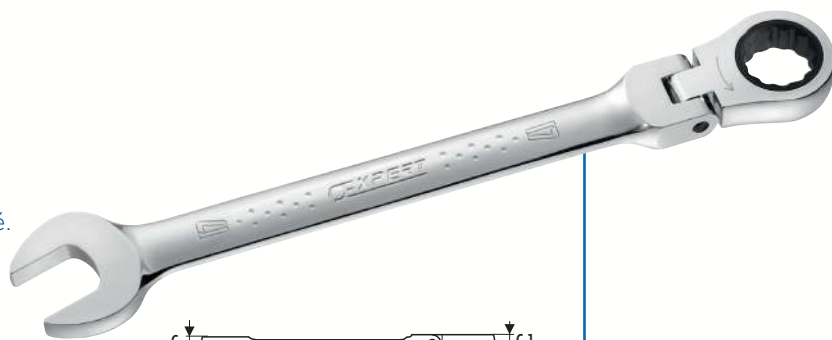

	A mm	B mm	B1 mm	C mm	C1 mm	L mm	Poids g	☒	EAN
E110901	8	17	17.5	5.5	7	136	40	1	3258951109014
E110902	9	19.2	19.3	5.8	7.6	143	50	1	3258951109021
E110903	10	21.3	21	6.1	7.7	160	65	1	3258951109038
E110904	11	23.7	22.7	6.4	8	168	75	1	3258951109045
E110905	12	25.8	24	6.7	8	174	90	1	3258951109052
E110906	13	26.8	26	7	9	180	110	1	3258951109069
E110907	14	30.4	27.7	7.3	9.4	193	130	1	3258951109076
E110908	15	32.1	29.1	7.7	10	200	140	1	3258951109083
E110909	16	33	30.7	8	10.6	216	180	1	3258951109090
E110910	17	37	32.6	8	10.9	233	205	1	3258951109106
E110911	18	38	33	8.6	11.2	239	230	1	3258951109113
E110912	19	40	34	9	11.5	250	270	1	3258951109120

JEUX DE CLÉS MIXTES À CLIQUET ARTICULÉES - MM



	Contenu	Contenant	Quantité	Poids g	☒	EAN
E111108	8-10-12-13-14-17-19 mm.	Rack plastique	7	990	1	3258951111086
E111102	8-9-10-11-12-13-14-15-16-17-18-19 mm.	Rack plastique	12	1620	1	3258951111024



CLÉS MIXTES À CLIQUET COURTES - MM

- ISO 691 - ISO 1711-1
- Angle de reprise 5°.
- Tête polygonale 12 pans droite.
- Changement de sens par retournement de la clé.
- Fourche orientée à 15° par rapport à l'axe du manche (angle de reprise 30°).
- Profil de l'œil maximisant la surface de contact avec l'écrou pour une longévité accrue.
- Clés courtes pour une meilleure accessibilité dans les espaces restreints.
- Forgées à partir d'acier au Chrome Vanadium.
- Finition : chromée, brillante.

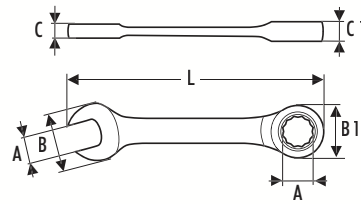

	A mm	B mm	B1 mm	C mm	C1 mm	L mm	Poids g	📦	EAN
E110914	10	21.3	21	5.5	7.7	96	40	1	3258951109144
E110916	12	25.4	24	6.1	8	104	55	1	3258951109168
E110917	13	26.8	26	6.3	9	108	65	1	3258951109175
E110918	14	29.8	27.7	6.7	9.4	114	80	1	3258951109182
E110919	15	31.6	29.1	7.1	10	118	100	1	3258951109199
E110921	17	36	32.6	7.8	10.9	128	125	1	3258951109212
E110923	19	40	34	8.5	11.5	138	155	1	3258951109236

JEU DE 7 CLÉS MIXTES À CLIQUET COURTES - MM

- Livré sur rack plastique.



	Contenu	Quantité	Poids g	📦	EAN
E111104	10-12-13-14-15-17-19 mm.	7	670	1	3258951111048





CLÉS POLYGONALES À CLIQUET

JEU DE 5 CLÉS POLYGONALES À CLIQUET - MM

→ Livré sur rack plastique.



E111103	Contenu	Quantité	Poids g	📦	EAN
	8x10-10x11-12x13-14x15-17x19 mm.	5	730	1	3258951111031

CLÉS À CLIQUET 4 EN 1

CLÉS À CLIQUET "4 EN 1" - MM

- 4 dimensions par clés.
- Tête polygonale 12 pans.
- Changement de sens par inverseur encastré et protégé.
- Finition : chromée, brillante.

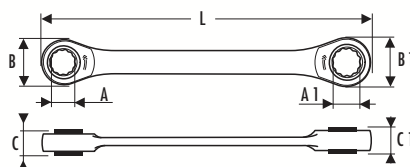

	A mm	A1 mm	B mm	B1 mm	C mm	C1 mm	L mm	Poids g	📦	EAN
E110943	8x10	12x13	21,5	26,5	8,9	9,8	160	100	1	3258951109434
E110944	9x11	14x15	23,1	29,7	8,9	10,4	180	130	1	3258951109441
E110945	16x17	18x19	34,5	35,6	11,7	12,2	230	265	1	3258951109458



JEU DE 3 CLÉS À CLIQUET "4 EN 1" - MM

→ Livré en blister.



E111115	Contenu	Quantité	Poids g	📦	EAN
	8x10-12x13 - 9x11-14x15 - 16x17-18x19	3	540	1	3258951111154



MODULES DE CLÉS À CLIQUET

MODULE DE 7 CLÉS MIXTES À CLIQUET ET 1 CLÉ À MOLETTE

- Plateau thermoformé.
- Conçu pour s'insérer dans les tiroirs de servante.
- Plateau vide : E010509.



E111100	Contenu	Quantité	Poids g	📦	EAN
	8-10-12-13-14-17-19 mm.- 250 mm.	8	1575	1	3258951111000

MODULE DE 12 CLÉS MIXTES À CLIQUET

- Plateau thermoformé.
- Conçu pour s'insérer dans les tiroirs de servante.
- Plateau vide : E195064.



E194938	Contenu	Quantité	Poids g	📦	EAN
	8-9-10-11-12-13-14-15-16-17-18-19 mm.	12	1592	1	3258951949382



CLÉS À FOURCHES

CLÉS À FOURCHES - MM

→ ISO 691 - ISO 1711-1 - ISO 3318 - ISO 10102 - DIN 3110

→ Fourche orientée à 15° par rapport à l'axe du manche (angle de reprise 30°).

→ Forgées à partir d'acier au Chrome Vanadium.

→ Finition : chromée, brillante.

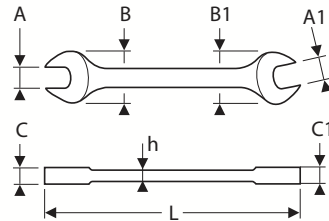
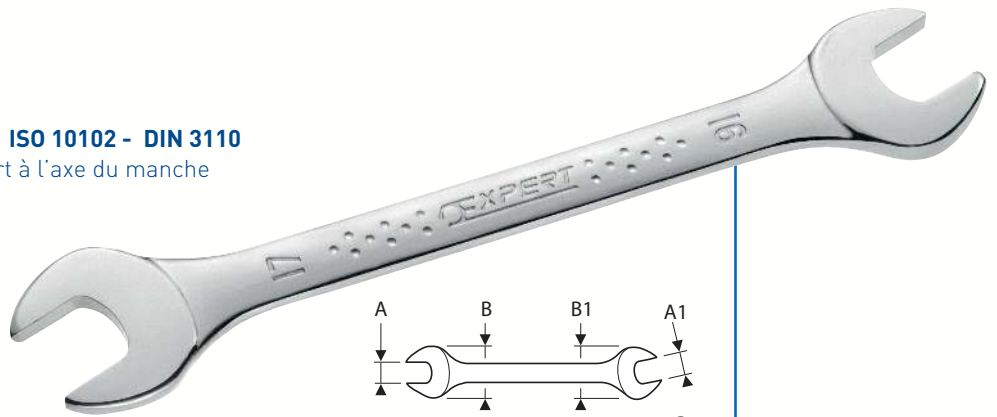

	A mm	A1 mm	B mm	B1 mm	C mm	C1 mm	L mm	Poids g		EAN
E113262	4	5	12.5	14.5	3.2	3.2	112	15	1	3258951132623
E113250	6	7	16	18	3.3	3.3	122	20	1	3258951132500
E113251	8	9	20	22	3.6	3.6	140	32	1	3258951132517
E113265	8	10	20	22	3.6	3.6	140	32	1	3258951132654
E113252	10	11	23.4	25.4	4	4	156	47	1	3258951132524
E113267	10	13	25.8	28.4	5	5	172	62	1	3258951132678
E113268	11	13	27.2	28.4	5	5	172	62	1	3258951132685
E113253	12	13	27.2	28.4	5	5	172	63	1	3258951132531
E113272	13	17	31.4	33.9	5.6	5.6	188	88	1	3258951132722
E113254	14	15	31.4	33.9	5.6	5.6	188	92	1	3258951132548
E113255	16	17	35.9	38	6.1	6.1	204	118	1	3258951132555
E113275	17	19	38.4	41.9	6.5	6.5	220	158	1	3258951132753
E113256	18	19	38.4	41.9	6.5	6.5	220	146	1	3258951132562
E113257	20	22	42	45.9	7.2	7.2	234	200	1	3258951132579
E113258	21	23	45.2	48.4	7.5	7.5	247	220	1	3258951132586
E113279	22	24	45.2	48.4	7.5	7.5	247	234	1	3258951132791
E111201	24	26	50.4	55.9	8	8	266	318	1	3258951112014
E113259	24	27	50.4	55.9	8	8	266	375	1	3258951132593
E113260	25	28	53.4	61.9	8.4	8.4	285	377	1	3258951132609
E113261	26	28	53.4	61.9	8.4	8.4	285	456	1	3258951132616
E113281	27	29	58.3	62.7	9.1	9.1	302	456	1	3258951132814
E113282	27	30	58.3	62.7	9.1	9.1	302	481	1	3258951132821
E113909	30	32	59.9	64	9.1	9.1	302	600	1	3258951139097
E113285	33	35	64	78	10	10	319	612	1	3258951132852
E113287	34	36	64	78	10	10	319	918	1	3258951132876
E113286	36	41	74.3	85.4	12.2	12.2	380	918	1	3258951132869
E113288	38	42	74.3	85.4	12.2	12.2	380	918	1	3258951132890
E111202	41	46	85	94	14.7	14.7	415	1450	1	3258951112021
E111203	46	50	94	103	15.7	15.7	465	1767	1	3258951112038





JEUX DE CLÉS À FOURCHES - MM



	Contenu	Contenant	Quantité	Poids g		EAN
E111406	4x5-6x7-8x9-10x11-12x13-14x15-16x17-18x19 mm.	Rack plastique	8	720	1	3258951114063
E117381	6x7-8x9-10x11-12x13-14x15-16x17-18x19-21x23-22x24-26x28-27x29-30x32 mm.	Boîte carton	12	2350	1	3258951173817
E111222	6x7-8x9-10x11-12x13-14x15-16x17-18x19-21x23-22x24-26x28-27x29-30x32 mm.	Trousse	12	2350	1	3258951112229
E117382	4x5-6x7-8x9-10x11-12x13-14x15-16x17-18x19-21x23-22x24-26x28-27x29-30x32-33x35-36x41-38x42 mm.	Boîte carton	16	4730	1	3258951173824

MODULE DE 11 CLÉS À FOURCHES

- Plateau thermoformé.
- Conçu pour s'insérer dans les tiroirs de servante.
- Plateau vide : E111221



	Contenu	Quantité	Poids g		EAN
E111220	6x7-8x9-10x11-12x13-14x15-16x17-18x19-21x23-22x24-27x29-30x32 mm.	11	2345	1	3258951112205



**CLÉS À FOURCHES DIN****CLÉS À FOURCHES DIN**

- DIN 894 - ISO 272 - ISO 1711-1 - ISO 691 - ISO 3318
- Fourche orientée à 15° par rapport à l'axe du manche.
(angle de reprise 30°)
- Forgées à partir d'acier allié haute qualité.
- Finition : phosphate noir.

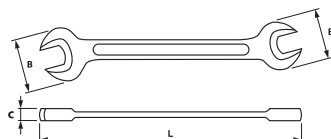

	A mm	A1 mm	B mm	B1 mm	C mm	L mm	Poids g		EAN
E114001	5.5	7	13	15	3	93	12	1	3258951140017
E114002	6	7	13	15	3	93	12	1	3258951140024
E114004	7	8	15	17	3.4	101	16	1	3258951140048
E114005	8	9	17	19	3.4	101	20	1	3258951140055
E114006	8	10	17	21	3.8	111	22	1	3258951140062
E114007	9	10	19	21	3.8	111	25	1	3258951140079
E114008	10	11	21	24	4.7	120	32	1	3258951140086
E114009	10	12	21	25	4.7	120	35	1	3258951140093
E114012	12	13	25	27	5.2	130	45	1	3258951140123
E114015	13	16	27	32.5	5.5	148	62	1	3258951140154
E114016	13	17	27	34.5	6	155	74	1	3258951140161
E114017	14	15	28.5	30.5	5.5	150	60	1	3258951140178
E114018	14	17	28.5	34.5	6	162	72	1	3258951140185
E114019	16	18	32.5	33.5	6.2	162	86	1	3258951140192
E114020	17	19	34.5	38.5	6.2	172	75	1	3258951140208
E114021	18	21	36.5	42	6.5	181	118	1	3258951140215
E114022	19	22	38.5	44	6.5	184	125	1	3258951140222
E114023	19	24	38.5	48	7.5	201	153	1	3258951140239
E114024	22	24	44	48	7.5	212	168	1	3258951140246
E114025	24	27	48	53	8.5	236	255	1	3258951140253
E114026	24	30	48	60	9.2	276	298	1	3258951140260
E114027	27	30	53	60	9.2	275	320	1	3258951140277
E114028	30	32	60	64	10.2	275	372	1	3258951140284
E114029	30	34	60	68	10.6	280	390	1	3258951140291
E114030	32	36	64	71	11.2	297	530	1	3258951140307
E114031	36	41	71	81	12.5	335	619	1	3258951140314
E114032	41	46	81	92	12.5	374	908	1	3258951140321
E114033	46	50	92	100	13	414	1130	1	3258951140338
E114034	55	60	110	120	14.4	480	1885	1	3258951140345



JEU DE 12 CLÉS À FOURCHES DIN - MM



	Contenu	Contenant	Quantité	Poids g	📦	EAN
E114040	5,5x7-8x9-10x11-12x13-13x17-14x15-16x18-17x19-19x22-24x27-24x30-30x32 mm	Trousse	12	1750	1	3258951140406



CLÉS POLYGONALES CONTRECOURBÉES

CLÉS POLYGONALES CONTRECOURBÉES - MM

- ISO 691 - ISO 1711-1 - ISO 3318 - ISO 10104 - DIN 838
- Tête polygonale 12 pans contrecourbées à 70° pour donner une meilleure accessibilité aux écrous noyés.
- Profil de l'œil maximisant la surface de contact avec l'écrou pour une longévité accrue.
- Forgées à partir d'acier au Chrome Vanadium.
- Finition : chromée, brillante.

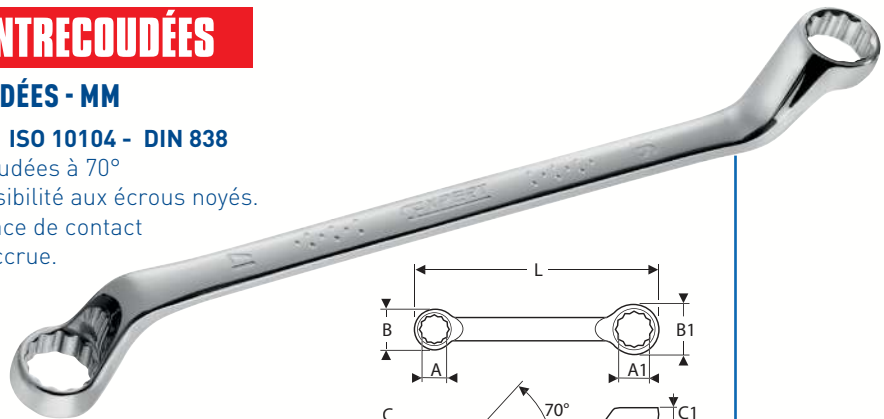

	A mm	A1 mm	B mm	B1 mm	C mm	C1 mm	L mm	Poids g	📦	EAN
E113321	6	7	10.8	12.5	4	5.6	170	45	1	3258951133217
E113322	8	9	13.4	15.3	6	6.8	182	70	1	3258951133224
E111501	8	10	13.4	15.5	6	7.4	190	79	1	3258951115015
E113323	10	11	16	17.8	7.4	7.9	206	90	1	3258951133231
E113324	12	13	18.8	20.2	8.4	8.9	213	126	1	3258951133248
E113364	13	17	19	25.2	9	11	245	170	1	3258951133644
E113325	14	15	20.8	22.5	9.4	9.9	228	155	1	3258951133255
E113326	16	17	24.2	25.7	10.4	10.9	246	193	1	3258951133262
E113366	17	19	27.6	28.7	11.4	11.9	265	250	1	3258951133668
E111500	18	19	27.6	28.7	11.4	11.9	265	241	1	3258951115008
E111502	19	22	29.7	32.5	12.4	12.9	288	314	1	3258951115022
E113328	20	22	29.7	32.5	12.4	12.9	288	315	1	3258951133286
E113730	21	23	31	33	12.3	13.3	310	352	1	3258951137307
E113329	22	24	31	33	12.3	13.3	310	344	1	3258951133293
E111503	24	27	34	39	13.7	14.3	330	475	1	3258951115039
E113367	25	28	36.6	40.5	14.2	14.7	348	548	1	3258951133675
E113368	27	29	42	45.2	15	16	372	662	1	3258951133682
E113369	27	30	42	45.2	15	16	372	662	1	3258951133699
E117376	30	32	42.2	45.5	15	16	372	635	1	3258951173763



CLÉS POLYGONALES CONTRECOURBÉES

JEUX DE CLÉS POLYGONALES CONTRECOURBÉES - MM



	Contenu	Contenant	Quantité	Poids g		EAN
E111709	20x22-21x23-24x27-27x30-30x32 mm.	Boîte carton	5	2575	1	3258951117095
E111708	8x9-10x11-12x13-14x15-16x17-18x19 mm.	Rack plastique	6	980	1	3258951117088
E111714	6x7-8x9-10x11-12x13-16x17-18x19-24x27-30x32 mm.	Trousse	8	1700	1	3258951117149

MODULE DE 8 CLÉS POLYGONALES CONTRECOURBÉES

- Plateau thermoformé.
- Conçu pour s'insérer dans les tiroirs de servante.
- Plateau vide : E111711



	Contenu	Quantité	Poids g		EAN
E111710	6x7-8x9-10x11-12x13-14x15-16x17-18x19-22x24 mm.	8	1576	1	3258951117101



CLÉS À PIPE

CLÉS À PIPE DÉBOUCHÉES 12 PANS X 6 PANS

- ISO 691 - ISO 2236
- Le coudage spécifique procure une grande résistance à la torsion.
- Le débouchage permet le passage d'une tige filetée et l'usage d'une broche pour augmenter le couple de serrage.
- Le poinçonnage profond dans les têtes permet le serrage même en cas de dépassement de la tige filetée.
- Forgées à partir d'acier au Chrome Vanadium.
- Finition : chromée, brillante.

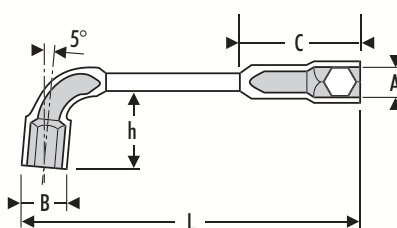

	A mm	B mm	C mm	L mm	Poids g	☒	EAN
E113458	6	10	23	102	30	1	3258951134580
E113459	7	11	24	106	40	1	3258951134597
E113370	8	12.5	27	114	55	1	3258951133705
E113371	9	13.5	28	122	75	1	3258951133712
E113372	10	15	30	129	90	1	3258951133729
E113373	11	16.5	32	136	110	1	3258951133736
E113374	12	18	38	144	150	1	3258951133743
E113375	13	19.5	40	152	165	1	3258951133750
E113376	14	21	42	160	200	1	3258951133767
E113377	15	22.5	44	169	220	1	3258951133774
E113378	16	24	49	178	270	1	3258951133781
E113379	17	25.5	51	187	310	1	3258951133798
E113380	18	26.5	53	195	330	1	3258951133804
E113381	19	28.5	54	204	410	1	3258951133811
E113382	20	29.5	56	212	465	1	3258951133828
E113383	21	30.5	58	221	490	1	3258951133835
E113384	22	32	60	230	525	1	3258951133842
E113385	23	33.5	67	240	640	1	3258951133859
E113386	24	34.5	70	250	640	1	3258951133866
E113388	27	38	77	280	960	1	3258951133880
E113389	30	42	87	310	1250	1	3258951133897
E113390	32	44.5	92	330	1425	1	3258951133903





CLÉS À PIPE

CLÉS À PIPE DÉBOUCHÉES 12 PANS X 6 PANS



	Pans	Contenu	Contenant	Quantité	Poids g		EAN
E117387	6 x 12	8-10-11-12-13-14-16-17-18-19 mm.	Boîte carton	10	2230	1	3258951173879
E117386	6 x 12	8-9-10-11-12-13-14-15-16-17-18-19-21-22-23-24 mm.	Boîte carton	16	4890	1	3258951173862
E112201	6 x 12	6-7-8-9-10-11-12-13-14-15-16-17-18-19-20-21-22-23-24-27-30-32 mm.	Boîte carton	22	9210	1	325895112013

CLÉS EN TUBE

CLÉS EN TUBE COUDÉES 6 PANS X 6 PANS

→ ISO 691 - ISO 2236

→ Permet le travail sur des tiges filetées longues.

→ Trou de passage permettant l'utilisation d'une broche.

→ Finition : chromée, brillante.



	A mm	B mm	H mm	L mm	Poids g		EAN
E113500	5	8	23.5	95	25	1	3258951135006
E113501	5.5	9	25	95	25	1	3258951135013
E113502	6	9.9	26.5	100	30	1	3258951135020
E113503	7	11.1	28.5	100	30	1	3258951135037
E113504	8	12.7	31.5	109	50	1	3258951135044
E113505	9	13.9	33	109	50	1	3258951135051
E113506	10	15.5	36.5	118	77	1	3258951135068
E113507	11	16.7	36.5	118	87	1	3258951135075
E113508	12	18	43	127	117	1	3258951135082
E113509	13	19.5	43	127	118	1	3258951135099
E113510	14	21.2	49	136	156	1	3258951135105
E113512	15	22.3	49	136	157	1	3258951135129
E113513	16	23.4	55	145	190	1	3258951135136
E113514	17	24.5	55	145	191	1	3258951135143
E113515	18	25.8	61	154	226	1	3258951135150
E113516	19	27	61	154	227	1	3258951135167
E113517	21	30.3	67.5	163	317	1	3258951135174
E113518	22	31.4	68	172	353	1	3258951135181
E113519	23	32.5	72.5	172	360	1	3258951135198
E113520	24	33	74.5	180	420	1	3258951135204

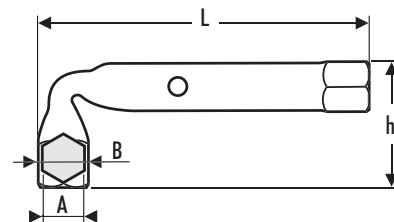



CLÉS EN TUBE DROITE 6X6 PANS

- UNI 6746 - ISO 2236 - DIN 896
- Trou de passage permettant l'utilisation d'une broche.
- Corps en acier au chrome molybdène.
- Finition : chrome poli.



	A mm	d mm	L mm	Poids g	☒	EAN
E112801	6x7	5.5	100	25	5	3258951128015
E112802	8x9	5.5	108	45	5	3258951128022
E112803	8x10	5.5	90	50	5	3258951128039
E112804	9x10	5.5	90	50	5	3258951128046
E112805	10x11	6.5	116	60	5	3258951128053
E112806	11x12	6.5	100	70	5	3258951128060
E112807	12x13	6.5	124	90	5	3258951128077
E112808	13x17	8.5	100	110	5	3258951128084
E112809	14x15	8	132	125	5	3258951128091
E112810	16x17	8	140	150	5	3258951128107
E112811	18x19	8	158	175	5	3258951128114
E112812	20x22	10	156	245	5	3258951128121
E112813	21x23	10	163	275	3	3258951128138
E112814	24x26	11	173	325	3	3258951128145
E112815	25x28	12.5	182	445	3	3258951128152
E112816	27x29	12.5	191	475	3	3258951128169
E112817	30x32	13.5	200	590	3	3258951128176

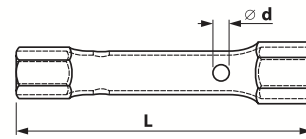

CLÉS EN TUBE HEXAGONALES SIMPLES

- Trou de passage permettant l'utilisation d'une broche.



	A mm	d mm	d1 mm	L mm	Poids g	☒	EAN
E112818	8	12	4.5	70	20	1	3258951128183
E112819	9	13.2	4.5	70	30	1	3258951128190
E112820	10	14.5	5.5	80	30	1	3258951128206
E112821	12	16.2	6.5	80	60	1	3258951128213
E112822	13	17.6	6.5	80	60	1	3258951128220
E112823	14	19.5	6.5	80	60	1	3258951128237
E112824	16	21.9	6.5	80	60	1	3258951128244
E112825	18	24.6	10.5	90	80	1	3258951128251
E112826	17	23.3	8.5	90	70	1	3258951128268
E112827	19	25.9	10.5	90	80	1	3258951128275
E112828	21	28.2	10.5	90	120	1	3258951128282
E112829	22	29.6	10.5	90	120	1	3258951128299
E112830	24	31.9	12.5	100	140	1	3258951128305
E112831	27	35.8	12.5	100	170	1	3258951128312
E112832	30	39.7	16.5	110	208	1	3258951128329

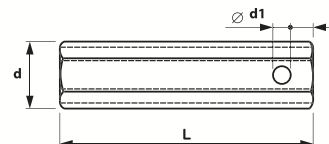



CLÉS EN TUBE

BROCHES

→ ISO 286-2

→ Pour contrôler les clés en tube

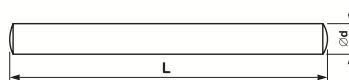

	d mm	L mm	Poids g	☒	EAN
E112901	6	125	30	1	3258951129012
E112902	8	160	60	1	3258951129029
E112903	10	220	140	1	3258951129036

CLÉS À TUYAUTER

CLÉS À TUYAUTER 6 PANS X 6 PANS

→ DIN 3118 - ISO 691

→ Fourche à tuyauter
coudée à 15°.

→ Profil 6 pans sur toutes les
dimensions de la gamme.

→ Forgées à partir d'acier
au Chrome Vanadium.

→ Finition : chromée, brillante.

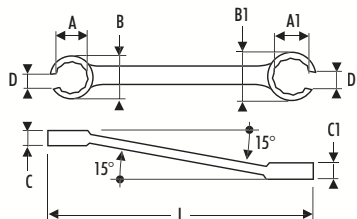

	A mm	A1 mm	B mm	B1 mm	C mm	C1 mm	d mm	d1 mm	L mm	Poids g	☒	EAN
E112301	7	9	17.8	19.3	6.5	7.5	6	6.5	139	41	1	3258951123010
E117388	8	10	17.8	19.3	6.5	7.5	6	7	139	41	1	3258951173886
E117391	11	13	22.8	25.3	6.5	7.5	6	7	174	82	1	3258951173916
E117392	12	14	22.8	25.3	8.5	10.5	9	11	174	77	1	3258951173923
E117394	17	19	31.2	33	12	13	14	15	213	182	1	3258951173947
E117395	19	22	33.4	38.4	13	14	15	17	228	229	1	3258951173954
E117368	24	27	42.4	46.4	16	17	18	20	255	412	1	3258951173688



JEU DE 5 CLÉS À TUYAUTER

→ Présentées sur rack plastique.



	Contenu	Quantité	Poids g	☒	EAN
E112501	7x9-8x10-11x13-12x14-17x19 mm.	5	470	1	3258951125014

CLÉS À MOLETTE

CLÉS À MOLETTE

- ISO 6787 - DIN 3117 - ASME B 107.8 M
- Tête inclinée à 15° permettant de ramener l'angle de débattement à 30° par retournement.
- Diminution de l'épaisseur des becs pour une meilleure accessibilité.
- Sens de rotation de la molette : à droite.
- Design arrondi de la poignée pour une meilleure ergonomie.
- Corps forgé à partir d'acier au Chrome Vanadium.
- Finition : chromée, faces polies.

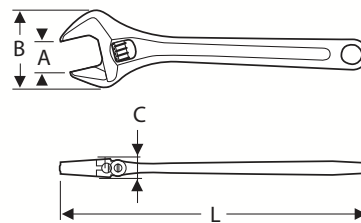

	A mm	B mm	C mm	L mm	Poids g	☒	EAN
E187366	20	46	10,8	6" - 150	130	1	3258951873663
E187368	24	57,4	13,5	8" - 200	240	1	3258951873687
E187470	29	69,8	16	10" - 250	440	1	3258951874707
E187472	34	82,3	19	12" - 300	700	1	3258951874721
E187473	44	104,3	25	15" - 375	1290	1	3258951874738
E117905	55	120	26	18" - 450	1950	1	3258951179055
E117906	62	132	31	24" - 600	3225	1	3258951179062





CLÉS À MOLETTE

CLÉS À MOLETTE MANCHE BI-MATIÈRE

- ISO 6787 - DIN 3117 - ASME B 107.8 M
- Tête inclinée à 15° permettant de ramener l'angle de débattement à 30° par retournement.
- Diminution de l'épaisseur des becs pour une meilleure accessibilité.
- Sens de rotation de la molette : à droite.
- Poignée plastique pour un meilleur confort.
- Corps forgé à partir d'acier au Chrome Vanadium.
- Finition : chromée, faces polies.

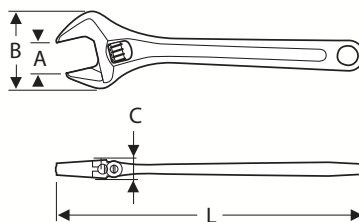

	A mm	B mm	C mm	L mm	Poids g		EAN
E112605	30	60.2	12.9	8" - 210	245	1	3258951126059
E112606	35	72.0	15.4	10" - 260	450	1	3258951126066
E112607	41	84.0	18.3	12" - 310	740	1	3258951126073

JEU DE 3 CLÉS À MOLETTE BI-MATIÈRE

- ISO 6787 - DIN 3117 - ASME B 107.8 M
- Tête inclinée à 15° permettant de ramener l'angle de débattement à 30° par retournement.
- Diminution de l'épaisseur des becs pour une meilleure accessibilité.
- Sens de rotation de la molette : à droite.
- Poignée plastique pour un meilleur confort.
- Corps forgé à partir d'acier au Chrome Vanadium.
- Finition : chromée, faces polies.



	Quantité	Poids g		EAN
E112703	3	1435	1	3258951127032



CLÉS À ERGOTS

CLÉS À ERGOTS

- Capacité 19 à 159 mm.
- Corps forgé à partir d'acier au Chrome Vanadium.
- Finition : chromée, brillante.

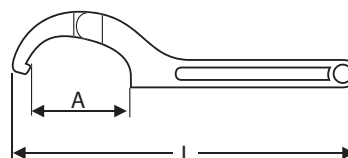

	A mm	L mm	Poids g	☐	EAN
E112601	19 - 51	165	130	1	3258951126011
E112602	32 - 76	216	225	1	3258951126028
E112603	51 - 121	267	455	1	3258951126035
E112604	114 - 159	308	490	1	3258951126042

CLÉS À ÉCHAFAUDAGE

CLÉS À ÉCHAFAUDAGE

- Spécial montage/démontage d'échafaudages.
- Mécanisme 32 dents.
- Changement de sens par inverseur encastré et protégé.
- Mécanisme à double face donne deux tailles par clé :
E110961 : 17 x 19 mm.
E110962 : 21 x 22 mm.
- Finition : Zinc.

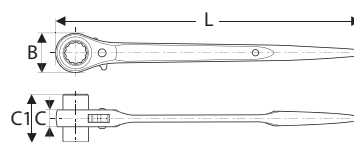

	B mm	C mm	C1 mm	L mm	Poids g	☐	EAN
E110961	40.7	17	50	309	430	1	3258951109618
E110962	40.7	17	50	309	714	1	3258951109625

CLÉ À ÉCHAFAUDAGE 19MM

- ISO 691
- Spécial montage/démontage d'échafaudages.
- Tête usinée afin d'être utilisée comme un marteau.
- Poignée percée pour l'utilisation d'une dragonne pour les travaux en hauteur.
- Finition : phosphaté noir.

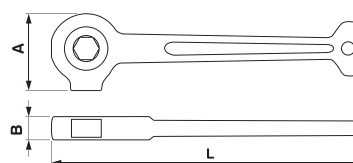

	A mm	B mm	L mm	Poids g	☐	EAN
E114301	65	28.5	270	780	1	3258951143018



CLIQUETS - DOUVILLES

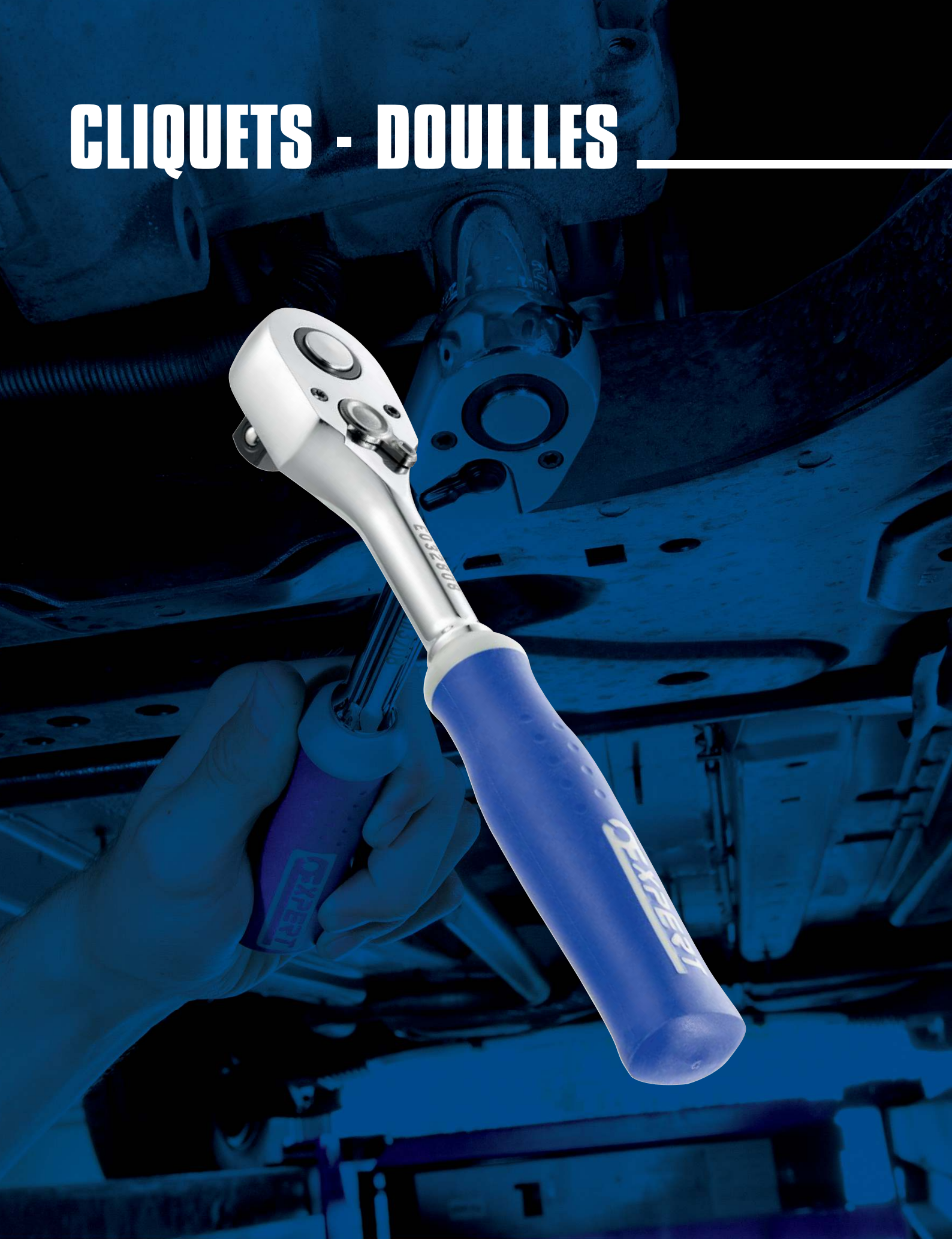



Compositions multi-carrés

P.50



Gamme 1/4"

P.54



Gamme 3/8"

P.66



Gamme 1/2"

P.77



Gamme 3/4"

P.95



Gamme 1"

P.100





→ RANGEMENT RÉSISTANT, COMPACT ET OPTIMISÉ

→ TAILLE

6 tailles de coffrets pour répondre à tous les besoins avec un maximum de compacité.

→ HABILLAGE

L'habillage intérieur des coffrets est fait de plateau plastique ou mousse suivant les besoins.

→ POIGNÉE

Les 2 plus grandes dimensions comportent une **poignée intégrée** pour faciliter leur transport sans nuire à la compacité ni à la modularité.

→ FERMETURE

Double fermoir intégré sur les deux plus grands modèles, assurant un verrouillage résistant et efficace.



L. 565 x P. 415 x H. 92 mm



L. 415 x P. 283 x H. 92 mm



→ STOCKAGE OPTIMUM DANS LES SERVANTES

→ DISPOSITION

Chaque coffret est **2 fois plus petit** que le coffret de dimension supérieure. La plus grande dimension étant pensée pour correspondre à la dimension d'un tiroir de servante Expert.

→ STOCKAGE

Le stockage des boîtes dans les tiroirs est donc **facile et optimisé**, que ce soit pour le rangement de boîtes fermées ou pour l'utilisation des coffrets comme des modules de servante.



OUVERTURE

En effet, **l'ouverture** des boîtes se fait à **100%**, permettant de les positionner complètement à plat dans les tiroirs.

Les tiroirs de servante peuvent ainsi être organisés avec des modules et/ou des boîtes fermées ou ouvertes, puisque tous ces éléments de rangements sont compatibles.



ASTUCE PRATIQUE

Le maintien des 2 parties des boîtes se fait par une charnière métallique escamotable. Il est ainsi possible et facile de séparer les boîtes en 2 plateaux afin de les utiliser comme des plateaux complètement indépendants.



L. 275 x P. 186 x H. 80 mm



L. 186 x P. 138 x H. 54 mm



L. 137 x P. 94 x H. 31 mm



L. 92 x P. 64 x H. 31 mm





COMPOSITIONS MULTI-CARRÉS

COFFRET DE DOUILLES, CLÉS ET ACCESSOIRES MÉTRIQUES 1/4" - 1/2" - 101 PIÈCES

- Douilles 1/4" 6 pans : 4-4,5-5-5,5-6-7-8-9-10-11-12-13-14 mm.
- Douilles tournevis 6 pans 1/4" : 3-4-5-6 mm.
- Douilles tournevis 1/4" : Pozidriv® PZ1-PZ2 - Phillips® PH1-PH2.
- Douilles tournevis Torx® 1/4" : T8-T10-T15-T20-T25-T27-T30.
- Douilles 6 pans 1/2" : 10-11-12-13-14-15-16-17-18-19-20-21-22-24-27-30-32 mm.
- Douilles longues 6 pans 1/2" : 13-17-19 mm.
- Douilles tournevis fente 1/4" : 4-5,5-7 mm.
- Embouts fente 5/16" : 8-12 mm.
- Embouts Phillips® 5/16" : PH3-PH4.
- Embouts Pozidriv® 5/16" : PZ3-PZ4.
- Embouts 6 pans 5/16" : 12-14 mm.
- Embouts Torx® 5/16" : T40-T45-T50-T55.
- Clés mâles sur étui : 1,5-2-2,5-3-4-5-6-7-8-9-10 mm.
- Clés mixtes : 7-8-10-11-12-13-14-15-16-17-18-19 mm.
- 1 cliquet parcmètre à verrouillage 1/4".
- 1 douille porte-embouts 1/4".
- 2 rallonges 1/4" : 55-100 mm.
- 1 cardan 1/4".
- 1 poignée coulissante 1/4".
- 1 poignée tournevis bi-matière 1/4".
- 1 cliquet parcmètre à verrouillage 1/2".
- 1 cardan 1/2".
- 2 rallonges 1/2" : 130-250 mm.
- 1 poignée coulissante 1/2".
- 2 douilles à bougie 1/2" : 16-21 mm.
- 1 adaptateur 1/2" pour embouts 5/16".
- Livré en boîte compatible tiroir de servante.



E032911	☑	Quantité	Dimensions	Poids kg	☒	EAN
E032911	☑	101	L.565xP.415xH.92 mm	8	5	3258950315256

MODULE DE DOUILLES ET ACCESSOIRES 1/4" - 3/8" MÉTRIQUES - 62 PIÈCES

- Douilles 1/4" 6 pans : 4-4,5-5-5,5-6-7-8-9-10-11-12-13-14 mm.
- Douilles 1/4" Torx® : T8-T10-T15-T20-T25-T27-T30-T40.
- Douilles tournevis 1/4" Torx® : T6-T7-T9.
- Douilles 3/8" 12 pans : 8-9-10-11-12-13-14-15-16-17-18-19-21-22 mm.
- Douilles longues 3/8" 6 pans : 8-9-10-11-12-13-14-15-16-17-18-19-21-22 mm.
- Douilles tournevis 3/8" Torx® : T45-T50-T55.
- 1 cliquet parcmètre à verrouillage 1/4".
- 1 cardan 1/4".
- 2 rallonges 1/4" : 55-100 mm.
- 1 cliquet parcmètre à verrouillage 3/8".
- 1 cardan 3/8".
- 1 rallonge 3/8" : 125 mm.
- Plateau vide : E034854.

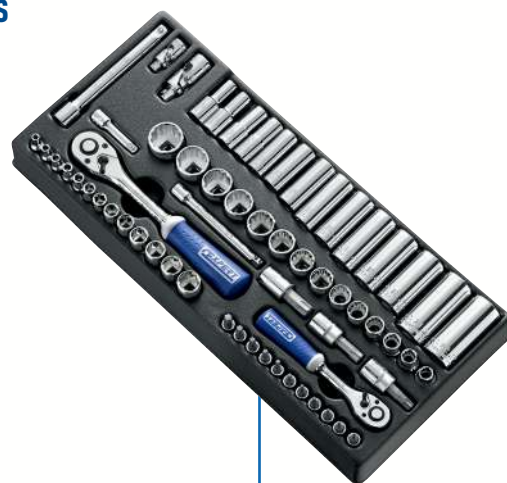

E034853	☑	Quantité	Poids kg	☒	EAN
E034853	☑	62	3,1	1	3258950348537



COFFRET DE DOUILLES ET ACCESSOIRES MÉTRIQUES 1/4" - 1/2" - 98 PIÈCES

- Douilles 1/4" 6 pans : 4-5-5,5-6-7-8-9-10-11-12-13 mm.
- Douilles longues 1/4" 6 pans : 6-8-10-11-12-13-14 mm.
- Embouts Torx® 1/4" : T6-T8-T10.
- Douilles tournevis fente 1/4" : 4-7 mm.
- Douilles tournevis Torx® 1/4" : T8-T10-T15-T20-T25-T27-T30.
- Douilles tournevis Pozidriv® 1/4" : PZ1-PZ2.
- Douilles tournevis Phillips® 1/4" : PH1-PH2.
- 1 cliquet parcmètre à verrouillage 1/4".
- 2 rallonges 1/4" : 55-100 mm.
- 1 cardan 1/4".
- 1 poignée coulissante 1/4".
- 1 poignée tournevis bi-matière.
- Douilles 1/2" 6 pans : 10-11-12-13-14-15-16-17-18-19-20-21-22-24-27-30-32 mm.
- Douilles longues 1/2" 6 pans : 14-15-17-19-22 mm.
- 2 douilles à bougie 1/2" : 16-21 mm.
- Douilles Torx® 1/2" : E12-E14-E16-E18-E20-E24.
- 1 cliquet parcmètre à verrouillage 1/2".
- 1 adaptateur 3/8" - 1/2".
- 1 douille 1/2" porte-embouts 5/16".
- 1 cardan 1/2".
- 2 rallonges 1/2" : 130-250 mm.
- Embouts XZN® 5/16" : 6-8-10-12.
- Embouts fente 5/16" : 8-12 mm.
- Embouts Torx® 5/16" : T40-T45-T50-T55.
- Embouts 6 pans 5/16" : 8-10-12-14 mm.
- Livré en boîte compatible tiroir de servante.



Code	Spécifications	Quantité	Dimensions	Poids kg	Boîte	EAN
E034805	1/4" - 1/2"	98	L.415xP.283xH.92	6,5	1	3258950348056

JEU DE DOUILLES TORX® 1/4" - 3/8" - 1/2" - 13 PIÈCES

- Douilles Torx® 1/4" : E4-E5-E6-E7-E8.
- Douilles Torx® 3/8" : E10-E12-E14-E16.
- Douilles Torx® 1/2" : E18-E20-E22-E24.
- Livré sur rack métallique.



Code	Spécifications	Quantité	Poids g	Boîte	EAN
E034801	1/4" - 3/8" - 1/2"	13	500	10	3258950348018





COMPOSITIONS MULTI-CARRÉS

COFFRET DE DOUILLES TOURNEVIS 6 PANS, TORX®, XZN - 38 PIÈCES

- Douilles tournevis 1/4" :
Résistorx®: TT10-TT15-TT20-TT25-TT27-TT30-TT40-TT45-TT50, L.37 mm.
- Douilles tournevis 1/2" :
Torx®: T40-T45-T50-T55-T60-T70, L.140 mm.
Résistorx®: TT30, L.230 mm – TT80, L.100 mm.
6 pans : 7 mm, L.230 mm – 10-11-13 mm, L.140 mm – 14-17-19-22-24 mm, L.50 mm.
6 pans tête sphérique : 5 mm, L.160 mm.
XZN®: M9, L.100 mm – M10-M12-M14, L.140 mm.
XZN® alésée: M16, L.55 mm – M16, L.100 mm.
XZN® impact: M18, L.75 mm.
Créneaux : 7-8 mm, L.240 mm – 9 mm, L.100mm – 10 mm, L.140 mm.
- Livré en boîte compatible tiroir de servante.



E200513	1/4" - 1/2"	Quantité	Dimensions	Poids kg	☒	EAN
		38	L.420xP.355xH.92mm	6,07	5	3258952005131

JEU DE DOUILLES TOURNEVIS 1/4" - 3/8" - 9 PIÈCES

- Douilles tournevis 6 pans 1/4" : 3-4-5-6 mm.
- Douilles tournevis 6 pans 3/8" : 7-8-9-10-12 mm.
- Livré sur rack métallique.



E034802	1/4" - 3/8"	Quantité	Poids g	☒	EAN
		9	300	10	3258950348025

JEU DE 3 ADAPTATEURS MAGNÉTIQUES

- Utilisation uniquement avec de l'outillage à main.
- Aimanté.
- Livré sur rack métallique.
- 3 adaptateurs :
E041505 : 1/4" à 3/8".
E041506 : 3/8" à 1/2".
E041507 : 1/2" à 3/4".



E041649	Quantité	Poids g	☒	EAN
	3	183	1	3258950416496



- Modularité
- Couvercle amovible
- Poignée ergonomique
- Fermeurs
- Robustesse

● ● ●	● ● ○
● ● ●	○ ○ ○
● ● ●	● ● ○
● ● ●	● ○ ○
● ● ●	● ● ○

COFFRET DE DOUILLES ET ACCESSOIRES 1/4" - 1/2" MÉTRIQUES - 44 PIÈCES

- Douilles 1/4" : 5,5-7-8-9-10-12-13 mm.
- 1 cliquet parcmètre à verouillage 1/4".
- 1 rallonge 1/4" : 55 mm.
- 1 douille 1/4" porte-embout à jonc de retenue standard
- 1 cliquet parcmètre à verouillage 1/4".
- Douilles 1/2" : 13-16-18-21-24-27-30-34 mm.
- Douilles tournevis 6 pans 1/2" : 8-10-12-14 mm.
- 2 rallonges 1/2" : 130-250 mm.
- 1 douille à bougie 1/2" : 16 mm.
- 1 poignée coulissante 1/2".
- Embouts (fentes, 6 pans, Pozidriv®, Torx®)
- 1 poignée tournevis bi-matière.



	☑	Quantité	Poids kg	📦	EAN	
E034855		1/4" - 1/2"	44	5,2	1	3258950348551





COMPOSITIONS DE DOUILLES ET ACCESSOIRES 1/4"

COFFRET DE DOUILLES ET ACCESSOIRES 1/4" MIXTE - 73 PIÈCES

- Douilles 1/4" 6 pans : 4-4,5-5-5,5-6-7-8-9-10-11-12-13-14 mm.
- Douilles longues 1/4" 6 pans : 5-5,5-6-7-8-10-11-12-13 mm.
- Douilles 1/4" 12 pans : 1/2"-1/4"-11/32"-3/16"-3/8"-5/16"-7/16"-7/32"-9/16"-9/32".
- Douilles tournevis fente 1/4" : 4-5,5-7 mm.
- Douilles tournevis Pozidriv® 1/4" : PZ1-PZ2-PZ3.
- Douilles tournevis Phillips® 1/4" : PH1-PH2-PH3.
- Douilles tournevis Torx® 1/4" : T6-T7-T8-T9-T10-T15-T20-T25-T30-T40.
- Douilles Torx® 1/4" : E4-E5-E6-E7-E8-E10.
- Douilles tournevis 6 pans 1/4" : 2-2,5-3-4-5-6-7-8 mm.
- 1 cliquet parcmètre à verrouillage 1/4".
- 3 rallonges 1/4" : 55-100-150 mm.
- 1 poignée tournevis bi-matière.
- 1 cardan universel 1/4".
- 1 poignée coulissante 1/4".
- 1 douille porte-embouts 1/4".
- Livré en boîte compatible tiroir de servante.



	▣	Quantité	Dimensions	Poids kg	☒	EAN
E030707	1/4"	73	L.275xP.186xH.80 mm	2	5	3258950307077



COFFRET DE DOUILLES ET ACCESSOIRES 1/4" MÉTRIQUES - 42 PIÈCES

- Douilles 1/4" 6 pans : 4-4,5-5-5,5-6-7-8-9-10-11-12-13-14 mm.
- Douilles tournevis Pozidriv® 1/4" : PZ1-PZ2-PZ3.
- Douilles tournevis Phillips® 1/4" : PH1-PH2-PH3.
- Douilles tournevis 6 pans 1/4" : 3-4-5-6-7-8 mm.
- Douilles tournevis Torx® 1/4" : T10-T15-T20-T25-T30-T40.
- Douilles tournevis fente 1/4" : 4-5,5-7 mm.
- 3 rallonges 1/4" : 55-100-150 mm.
- 1 poignée coulissante 1/4".
- 1 poignée tournevis bi-matière.
- 1 cardan universel 1/4".
- 1 cliquet parcmètre à verrouillage 1/4".
- 1 douille porte-embouts 1/4".
- Livré en boîte compatible tiroir de servante.



	▣	Quantité	Dimensions	Poids kg	☒	EAN
E030702	1/4"	42	L.275xP.186xH.80 mm	1,5	10	3258950307022



COFFRET DOUILLES ET ACCESSOIRES 1/4" MÉTRIQUES - 34 PIÈCES

- Douilles 1/4" 6 pans : 4-4,5-5-5,5-6-7-8-9-10-11-12-13-14 mm.
- Embouts fente : 4-5,5-6,5 mm.
- Embouts Pozidriv® 1/4" : PZ1-PZ2-PZ3.
- Embouts Résistorx® 1/4" : TT10-TT15-TT20-TT25-TT30-TT40.
- Embouts 6 pans : 4-5-6 mm.
- 1 adaptateur embouts 1/4".
- 2 rallonges 1/4" : 55-100 mm.
- 1 cardan universel 1/4".
- 1 poignée tournevis bi-matière.
- 1 cliquet parcmètre à verrouillage 1/4".
- Livré en boîte compatible tiroir de servante.



E194672	1/4"	Quantité	Dimensions	Poids kg	📦	EAN
E194672	1/4"	34	L.186xP.138xH.54 mm	1	4	3258951946725

COFFRET DE DOUILLES ET ACCESSOIRES 1/4" MÉTRIQUES - 19 PIÈCES

- Douilles 1/4" 6 pans : 4-4,5-5-5,5-6-7-8-9-10-11-12-13-14 mm.
- 1 cliquet parcmètre à verrouillage 1/4".
- 2 rallonges 1/4" : 55-100 mm.
- 1 cardan 1/4".
- 1 adaptateur 1/4 pour embouts 1/4".
- 1 poignée coulissante 1/4".
- Livré en boîte compatible tiroir de servante.



E030700	1/4"	Quantité	Dimensions	Poids kg	📦	EAN
E030700	1/4"	19	L.186xP.138xH.54 mm	0,75	10	3258950307008





COMPOSITIONS DE DOUILLES ET ACCESSOIRES 1/4"

JEU DE DOUILLES 1/4" - 13 PIÈCES

- Douilles 1/4" 6 pans : 4-4,5-5-5,5-6-7-8-9-10-11-12-13-14 mm.
- Livré sur rack métallique.



		Quantité	Poids g		EAN
E194675	1/4"	13	370	10	3258951946756

JEU DE DOUILLES 1/4" - 22 PIÈCES

- Douilles 1/4" 6 pans : 4-4,5-5-5,5-6-7-8-9-10-11-12-13-14 mm.
- Douilles tournevis 6 pans : 2-3-4-6 mm.
- Douilles tournevis Torx® : T20-T25-T30.
- 1 cliquet parcmètre à verrouillage 1/4".
- 1 rallonge 1/4" : 150 mm.
- Livré sur rack.



		Quantité	Poids g		EAN
E030727	1/4"	22	626	1	3258950307275



MODULE DE DOUILLES ET ACCESSOIRES 1/4" MÉTRIQUES - 67 PIÈCES

- Douilles 1/4" 6 pans : 4-4,5-5-5,5-6-7-8-9-10-11-12-13-14 mm.
- Douilles longues 1/4" 6 pans : 4-5-5,5-6-7-8-9-10-11-12-13-14 mm.
- Douilles tournevis hexagonales 1/4" : 2-2,5-3-4-5-6-7-8 mm.
- Douilles tournevis Torx® 1/4" : T6-T7-T8-T9-T10-T15-T20-T25-T27-T30.
- 1 cliquet à tête articulée 1/4".
- 1 cliquet parcmètre à verrouillage 1/4".
- 1 poignée emmanchée 1/4".
- 2 rallonges 1/4" : 55-100 mm.
- 1 cardan 1/4".
- 1 poignée coulissante 1/4".
- 1 douille porte-embouts 1/4".
- Embouts fente 1/4" : 4-5,5-6,5 mm.
- Embouts Pozidriv® 1/4" : PZ1-PZ2-PZ3.
- Embouts 6 pans 1/4" : 3-4-5-6 mm.
- Embouts Resistorx® : TT10-TT15-TT20-TT25-TT30-TT40.
- Plateau vide: E030716.



E030715	1/4"	Quantité	Poids kg	1	EAN
		67	1,7	1	3258950307152

MODULE DE DOUILLES ET ACCESSOIRES 1/4" MÉTRIQUES - 45 PIÈCES

- Douilles 6 pans 1/4" : 4-4,5-5-5,5-6-7-8-9-10-11-12-13-14 mm.
- Embouts fente 1/4" : 4-5,5-6,5 mm.
- Embouts Pozidriv® 1/4" : PZ1-PZ2-PZ3.
- Embouts 6 pans 1/4" : 3-4-5-6 mm.
- Embouts Torx® 1/4" : T10-T15-T20-T25-T30-T40.
- 1 cliquet parcmètre à verrouillage 1/4".
- 2 rallonges 1/4" : 55-100 mm.
- 1 poignée tournevis bi-matière.
- 1 adaptateur 1/4" pour embouts 1/4".
- 1 cardan 1/4".
- 9 clés mâles sur étui : 1,5-2-2,5-3-4-5-6-7-8-10 mm.
- Plateau vide : E030701.



E194680	1/4"	Quantité	Poids kg	1	EAN
		45	1,3	1	3258950306018





CLIQUETS 1/4"

CLIQUET TÊTE RONDE 1/4"

- ISO 3315 - DIN 3122 - ISO 1174-1
- Mécanisme 72 dents.
- Angle de reprise 5°.
- Tête compacte.
- Finition : chrome brillant.
- Poignée bi-matière ergonomique.



E030601	d1 mm	d2 mm	L mm	Poids g		EAN
E030601	24.8	23.5	140	98	10	3258950306018

CLIQUET PARCMÈTRE À VERROUILLAGE 1/4"

- ISO 3315 - DIN 3122 - ISO 1174-1
- Mécanisme 72 dents.
- Angle de reprise 5°.
- Verrouillage de sécurité de la douille.
- Inversion par levier : visualisation du sens de rotation.
- Finition : chrome brillant.
- Poignée bi-matière ergonomique.
- Kit de réparation disponible: E034901.



E030605	d1 mm	d2 mm	L mm	Poids g		EAN
E030605	24	22	140	125	10	3258950306056

CLIQUET PARCMÈTRE À VERROUILLAGE 1/4" MANCHE MÉTAL

- ISO 3315 - DIN 3122 - ISO 1174-1
- Mécanisme 72 dents.
- Angle de reprise 5°.
- Verrouillage de sécurité de la douille.
- Inversion par levier : visualisation du sens de rotation.
- Finition : chrome brillant.

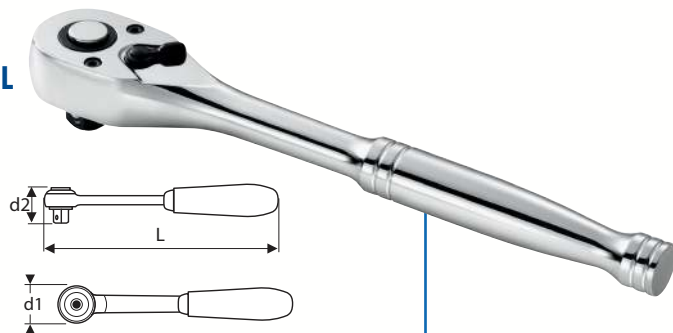

E030508	d1 mm	d2 mm	L mm	Poids g		EAN
E030508	24	22	140	136	10	3258950305080

CLIQUET À TÊTE ARTICULÉE 1/4"

- ISO 3315 - DIN 3122 - ISO 1174-1
- Mécanisme 72 dents.
- Angle de reprise 5°.
- Tête compacte et articulée pour une accessibilité accrue.
- Finition : chrome brillant.
- Poignée bi-matière ergonomique.



E030602	d1 mm	d2 mm	L mm	Poids g		EAN
E030602	31.6	23.5	150,5	130	1	3258950306025



ACCESSOIRES 1/4"

POIGNÉE EMMANCHÉE 1/4"

- ISO 3315 - DIN 3122
- Poignée bi-matière ergonomique.
- Acier au chrome vanadium.
- Finition : chrome brillant.
- Pour une utilisation manuelle.



E113910	L mm	Poids g	📦	EAN
E113910	158	70	5	3258951139103

POIGNÉE COULISSANTE 1/4"

- ISO 3315 - DIN 3122 - ISO 1174-1
- Acier au chrome vanadium.
- Finition : chrome brillant.
- Pour une utilisation manuelle.

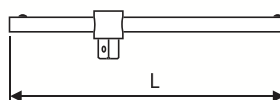

E117355	L mm	Poids g	📦	EAN
E117355	105	45	10	3258951173558

RALLONGES 1/4"

- ISO 3315 - DIN 3122 - ISO 1174-1
- Acier au chrome vanadium.
- Finition : chrome brillant.

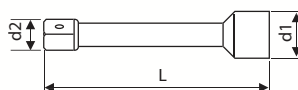
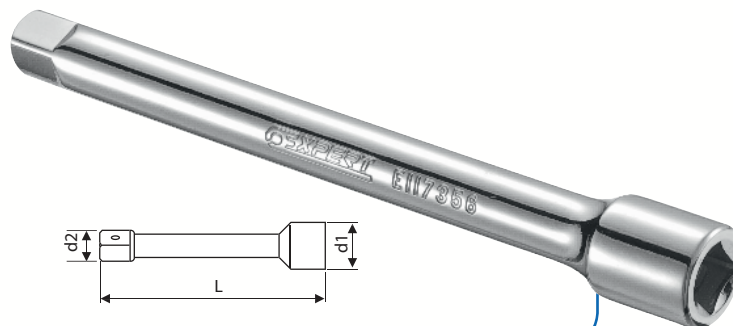

	d1 mm	d2 mm	L mm	Poids g	📦	EAN
E113771	12.5	8.51	55	25	10	3258951137710
E117356	12.5	8.51	100	45	10	3258951173565
E113772	12.5	8.51	150	65	10	3258951137727

RALLONGE FLEXIBLE - 1/4" - 150 MM

- Idéal pour le serrage et desserrage dans des espaces restreints.
- Corps souple.
- Utilisation manuelle (pas d'outils énergisés).

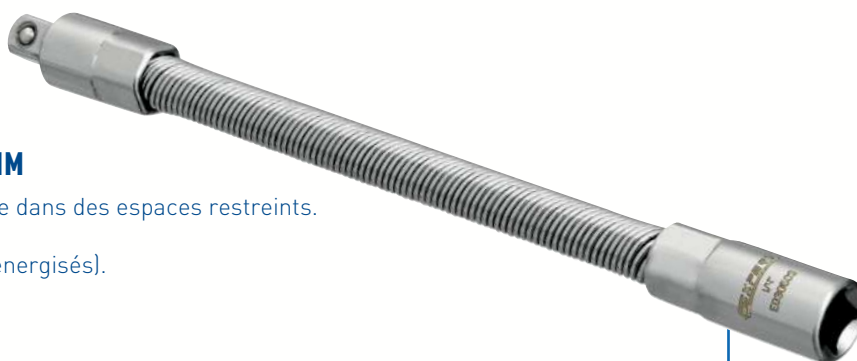

E030509	📦	EAN
E030509	1	3258950305097





ACCESSOIRES 1/4"

AUGMENTATEUR 1/4" - 3/8"

- ISO 3315 - DIN 3122 - ISO 1174-1
- Acier au chrome vanadium.
- Finition : chrome brillant.
- Pour une utilisation manuelle.

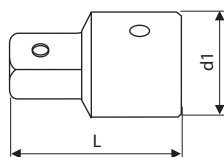

E117358	d1 mm	d2 mm	L mm	Poids g		EAN
E117358	12,4	8,51	25	16	10	3258951173589

ADAPTATEUR MAGNÉTIQUE 1/4" - 3/8"

- Utilisation uniquement avec de l'outillage à main.
- Aimanté.
- Livré sur rack métallique.

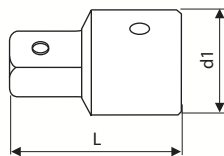

E041505		d1 mm	L mm	Poids g		EAN
E041505	1/4" - 3/8"	19	14,5	18	1	3258950415055

DOUILLE PORTE-EMBOUTS 1/4"

- ISO 1173 - DIN 3126 - ISO 1174-1
- Acier au chrome vanadium.
- Finition : chrome brillant.
- Pour une utilisation manuelle.

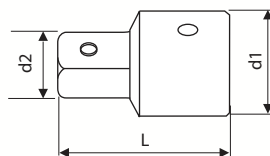

E117359	d1 mm	d2 mm	L mm	Poids g		EAN
E117359	14	8,51	25	25	10	3258951173596

CARDAN 1/4"

- ISO 3316 - DIN 3123 - ISO 1174-1
- Acier au chrome vanadium.
- Finition : chrome brillant.
- Pour une utilisation manuelle.

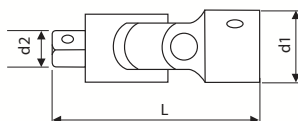

E117360	d1 mm	d2 mm	L mm	Poids g		EAN
E117360	14	8,51	25,20	22	10	3258951173602



DOUILLES 1/4"

DOUILLES 1/4" - 6 PANS - MÉTRIQUES

- ISO 2725-1 - DIN 3124 - ISO 1174-1 - ISO 1711-1 - ISO 691
- Acier au chrome vanadium.
- Profil Maxi Drive : transmission du couple de serrage sur les flancs de l'écrou et non sur les arêtes.
- Finition : chrome brillant.
- Pour une utilisation manuelle.

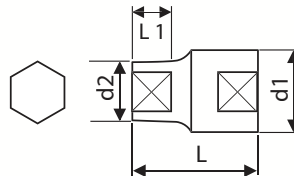

	A mm	d1 mm	d2 mm	L mm	L1 mm	Poids g	☒	EAN
E117293	4	12	6.9	25	3.6	10	10	3258951172933
E117688	4,5	12	7.5	25	3.6	10	10	3258951176887
E117294	5	12	8.1	25	4.2	10	10	3258951172940
E117295	5,5	12	8.8	25	4.2	10	10	3258951172957
E117296	6	12	9.4	25	4.8	10	10	3258951172964
E117297	7	12	10.9	25	5.4	12	10	3258951172971
E117298	8	12	12	25	5.4	12	10	3258951172988
E117299	9	13.2	13.2	25	6	14	10	3258951172995
E117350	10	14.7	14.7	25	7	18	10	3258951173503
E117351	11	16	16	25	8	24	10	3258951173510
E117352	12	16.9	16.9	25	8	24	10	3258951173527
E117353	13	17.7	17.7	25	8	26	10	3258951173534
E117354	14	19.7	19.7	25	10	34	10	3258951173541

DOUILLES 1/4" - 12 PANS - MÉTRIQUES

- ISO 2725-1 - DIN 3124 - ISO 1174-1 - ISO 1711-1 - ISO 691
- Acier au chrome vanadium.
- Profil Maxi Drive : transmission du couple de serrage sur les flancs de l'écrou et non sur les arêtes.
- Finition : chrome brillant.
- Pour une utilisation manuelle.

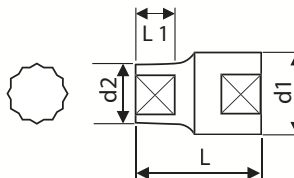

	A mm	d1 mm	d2 mm	L mm	L1 mm	Poids g	☒	EAN
E030210	6	12	9.4	25	4.8	10	10	3258950302102
E030201	7	12	10.9	25	5.4	12	10	3258950302010
E030202	8	12	12	25	5.4	12	10	3258950302027
E030203	9	13.2	13.2	25	6	14	10	3258950302034
E030204	10	14.7	14.7	25	7	18	10	3258950302041
E030205	11	16	16	25	8	24	10	3258950302058
E030206	12	16.9	16.9	25	8	24	10	3258950302065
E030207	13	17.7	17.7	25	8	26	10	3258950302072
E030211	14	19.7	19.7	25	10	34	10	3258950302119





DOUILLES 1/4"

DOUILLES 1/4" - 12 PANS - POUCES

- ASME B 107-1 - ISO 1174-1
- Acier au chrome vanadium.
- Profil Maxi Drive : transmission du couple de serrage sur les flancs de l'écrou et non sur les arêtes.
- Finition : chrome brillant.
- Pour une utilisation manuelle.

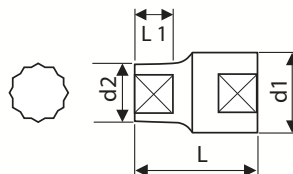

	A"	d1 mm	d2 mm	L mm	L1 mm	Poids g	☒	EAN
E113740	3/16"	12	8	25	3.6	7	10	3258951137406
E113741	7/32"	12	9	25	4.2	8	10	3258951137413
E113742	1/4"	12	10	25	4.8	8	10	3258951137420
E113743	9/32"	12	11	25	4	10	10	3258951137437
E113744	5/16"	12	12	25	4	10	10	3258951137444
E113745	11/32"	13.2	13.2	25	4.5	10	10	3258951137451
E113746	3/8"	14.7	14.7	25	4.5	14	10	3258951137468
E113748	7/16"	16	16	25	6	17	10	3258951137482
E113749	1/2"	17.7	17.7	25	7.2	19	10	3258951137499
E113750	9/16"	18.7	18.7	25	10	25	10	3258951137505

DOUILLES LONGUES 1/4" - 6 PANS - MÉTRIQUES

- ISO 2725-1 - DIN 3124 - ISO 1174-1 - ISO 1711-1 - ISO 691
- Acier au chrome vanadium.
- Profil Maxi Drive : transmission du couple de serrage sur les flancs de l'écrou et non sur les arêtes.
- Finition : chrome brillant.
- Pour une utilisation manuelle.

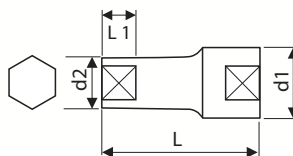

	A mm	d1 mm	d2 mm	L mm	L1 mm	Poids g	☒	EAN
E113751	4	11.8	6.9	49.5	5	18	10	3258951137512
E113752	5	11.8	8	49.5	5.5	18	10	3258951137529
E113753	5.5	11.8	8	49.5	5.5	18	10	3258951137536
E113754	6	11.8	9.4	49.5	6.5	18	10	3258951137543
E113755	7	11.8	10.9	49.5	10.5	27	10	3258951137550
E113756	8	11.8	11.8	49.5	10.5	27	10	3258951137567
E113757	9	12.8	12.8	49.5	11.5	32	10	3258951137574
E113758	10	14.5	14.5	49.5	13	41	10	3258951137581
E113759	11	15.6	15.6	49.5	14	15	10	3258951137598
E113760	12	16	16	49.5	15	50	10	3258951137604
E113761	13	17	17	49.5	17	59	10	3258951137611
E113762	14	19	19	49.5	19	68	10	3258951137628



DOUILLES LONGUES 1/4" - 6 PANS - POUCES

- ASME B 107-1 - ISO 1174-1
- Acier au chrome vanadium.
- Profil Maxi Drive : transmission du couple de serrage sur les flancs de l'écrou et non sur les arêtes.
- Finition : chrome brillant.
- Pour une utilisation manuelle.

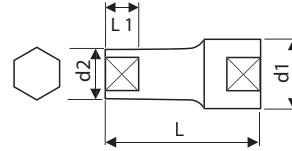

	A "	d1 mm	d2 mm	L mm	L1 mm	Poids g	☒	EAN
E030310	3/16"	11.8	8	49.5	5	18	10	3258950303109
E030311	7/32"	11.8	9	49.5	5.5	18	10	3258950303116
E030312	1/4"	11.8	10	49.5	6.5	23	10	3258950303123
E030313	9/32"	11.8	11	49.5	6.5	26	10	3258950303130
E030314	5/16"	11.8	11.8	49.5	10.5	27	10	3258950303147
E030315	11/32"	12.8	12.8	49.5	11.5	32	10	3258950303154
E030316	3/8"	14.5	14.5	49.5	12.5	41	10	3258950303161
E030317	7/16"	15.6	15.6	49.5	14.5	45	10	3258950303178
E030318	1/2"	17.6	17.6	49.5	16.5	59	10	3258950303185
E030322	9/16"	19.6	19.6	49.5	19	68	10	3258950303222

DOUILLES LONGUES 1/4" - 12 PANS - MÉTRIQUES

- ISO 2725-1 - DIN 3124 - ISO 1174-1 - ISO 1711-1 - ISO 691
- Acier au chrome vanadium.
- Profil Maxi Drive : transmission du couple de serrage sur les flancs de l'écrou et non sur les arêtes.
- Finition : chrome brillant.
- Pour une utilisation manuelle.

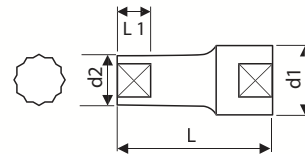

	A mm	d1 mm	d2 mm	L mm	L1 mm	Poids g	☒	EAN
E030216	6	11.8	9.4	49,50	6.5	18	10	3258950302164
E030217	7	11.8	10.9	49,50	10.5	27	10	3258950302171
E030218	8	11.8	11.8	49,50	10.5	27	10	3258950302188
E030219	9	12.8	12.8	49,50	11.5	32	10	3258950302195
E030220	10	14.5	14.5	49,50	13	41	10	3258950302201
E030221	11	15.6	15.6	49,50	14	45	10	3258950302218
E030222	12	16.6	16.6	49,50	15	50	10	3258950302225
E030223	13	17.6	17.6	49,50	17	59	10	3258950302232
E030224	14	19.6	19.6	49,50	19	68	10	3258950302249

DOUILLES LONGUES 1/4" - 12 PANS - POUCES

- ASME B 107-1 - ISO 1174-1
- Acier au chrome vanadium.
- Profil Maxi Drive : transmission du couple de serrage sur les flancs de l'écrou et non sur les arêtes.
- Finition : chrome brillant.
- Pour une utilisation manuelle.

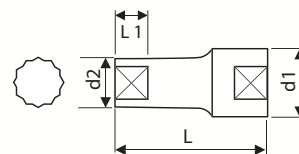

	A "	d1 mm	d2 mm	L mm	L1 mm	Poids g	☒	EAN
E113763	1/4"	11.8	10	49,5	6.5	17	10	3258951137635
E113764	3/8"	14.5	14.5	49,5	12.5	32	10	3258951137642
E113765	5/16"	11.8	11.8	49,5	10.5	23	10	3258951137659
E113766	7/16"	15.6	15.6	49,5	14.5	40	10	3258951137666
E113767	9/16"	19.6	19.6	49,5	19	49	10	3258951137673
E113768	9/32"	11.8	11.8	49,5	6.5	17	10	3258951137680





DOUILLES TORX® 1/4"

DOUILLES TORX® 1/4"

- ISO 1174-1
- Pour vis mâles Torx®.
- Acier au chrome vanadium.
- Finition : chrome brillant.

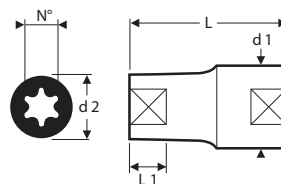

	N°	d1 mm	d2 mm	L mm	L1 mm	Poids g	☒	EAN
E030129	E4	12	6.1	25	3.6	8	10	3258950301297
E030130	E5	12	6.9	25	4.2	8	10	3258950301303
E030131	E6	12	8	25	4.8	8	10	3258950301310
E030132	E7	12	8.8	25	5.4	8	10	3258950301327
E030133	E8	12	10.2	25	5.4	9	10	3258950301334
E030134	E10	12	12	25	7	11	10	3258950301341
E030150	E11	12	12.8	25	6	14	1	3258950301501
E030151	E12	12	15.7	25	9	22	1	3258950301518

DOUILLES TOURNEVIS 1/4"

JEUX DE DOUILLES TOURNEVIS

- E030704 : 6 pans 2-2,5-3-4-5-6-7-8 mm.
- E030703 : Torx® T6-T7-T8-T9-T10-T15-T20-T25-T27-T30.
- Livrés sur rack métallique.

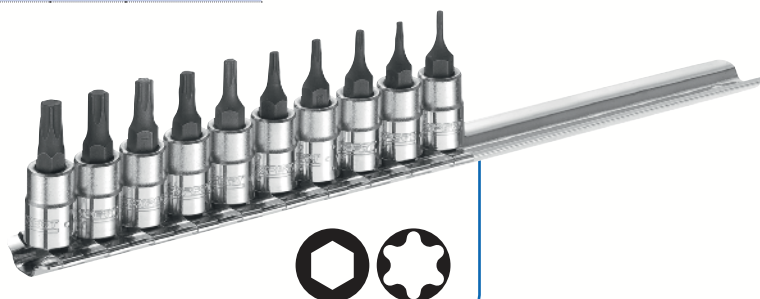

	☒	Quantité	Poids g	☒	EAN
E030704	1/4"	8	150	1	3258950307046
E030703	1/4"	10	190	1	3258950307039

DOUILLES TOURNEVIS 1/4" POUR VIS 6 PANS CREUX

- ISO 2725-1 - DIN3124 - ISO 1174-1
- Acier au chrome vanadium.
- Finition : chrome brillant.

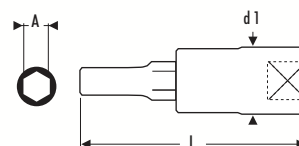

	A mm	d1 mm	L mm	Poids g	☒	EAN
E030101	2	12	33	18	10	3258950301013
E030102	2,5	12	33	18	10	3258950301020
E030103	3	12	33	18	10	3258950301037
E030104	4	12	33	18	10	3258950301044
E030105	5	12	33	19	10	3258950301051
E030106	6	12	33	20	10	3258950301068
E030107	7	12	33	21	10	3258950301075
E030108	8	12	33	22	10	3258950301082

DOUILLES TOURNEVIS 1/4" POUR VIS À FENTE

- ISO 2725-1 - DIN3124 - ISO 1174-1
- Acier au chrome vanadium.
- Finition : chrome brillant.

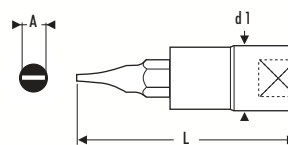

	A mm	d1 mm	L mm	Poids g	☒	EAN
E030109	4	12	33	12	10	3258950301099
E030110	5,5	12	33	12	10	3258950301105
E030111	7	12	33	12	10	3258950301112



DOUILLES TOURNEVIS 1/4" POUR VIS PHILLIPS®

- ISO 2725-1 - DIN3124 - ISO 1174-1
- Acier au chrome vanadium.
- Finition : chrome brillant.

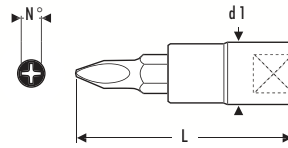

	N°	d1 mm	L mm	Poids g	☒	EAN
E030115	PH1	12	33	12	10	3258950301150
E030116	PH2	12	33	12	10	3258950301167
E030117	PH3	12	33	12	10	3258950301174

DOUILLES TOURNEVIS 1/4" POUR VIS POZIDRIV®

- ISO 2725-1 - DIN3124 - ISO 1174-1
- Acier au chrome vanadium.
- Finition : chrome brillant.

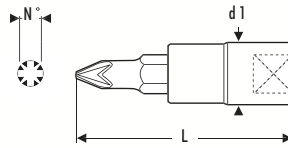

	N°	d1 mm	L mm	Poids g	☒	EAN
E030112	PZ1	12	33	12	10	3258950301129
E030113	PZ2	12	33	12	10	3258950301136
E030114	PZ3	12	33	12	10	3258950301143

DOUILLES TOURNEVIS 1/4" POUR VIS TORX®

- ISO 1174-1
- Acier au chrome vanadium.
- Finition : chrome brillant.

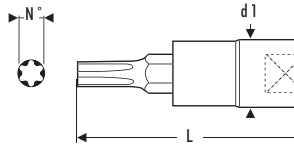

	N°	d1 mm	L mm	Poids g	☒	EAN
E030118	T6	12	33	17	10	3258950301181
E030119	T7	12	33	17	10	3258950301198
E030120	T8	12	33	17	10	3258950301204
E030121	T9	12	33	17	10	3258950301211
E030122	T10	12	33	17	10	3258950301228
E030123	T15	12	33	17	10	3258950301235
E030124	T20	12	33	18	10	3258950301242
E030125	T25	12	33	18	10	3258950301259
E030126	T27	12	33	18	10	3258950301266
E030127	T30	12	33	18	10	3258950301273
E030128	T40	12	33	18	10	3258950301280

DOUILLES TOURNEVIS 1/4" POUR VIS RESISTORX®

- ISO 1174-1
- Acier au chrome vanadium.
- Finition : chrome brillant.

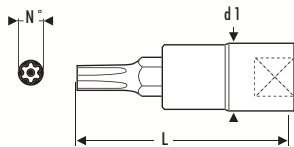

	N°	d1 mm	L mm	Poids g	☒	EAN
E030142	TT8	12	33	17	10	3258950301426
E030143	TT10	12	33	17	10	3258950301433
E030144	TT15	12	33	17	10	3258950301440
E030145	TT20	12	33	18	10	3258950301457
E030146	TT25	12	33	18	10	3258950301464
E030147	TT27	12	33	18	10	3258950301471
E030148	TT30	12	33	18	10	3258950301488
E030149	TT40	12	33	18	10	3258950301495

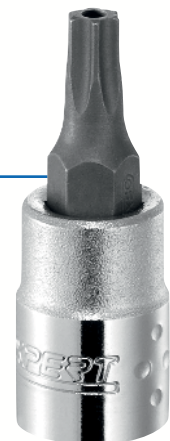
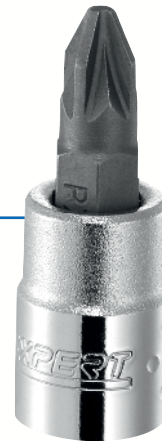



COMPOSITIONS DE DOUILLES ET ACCESSOIRES 3/8"

COFFRET DE DOUILLES ET ACCESSOIRES 3/8" MÉTRIQUES - 61 PIÈCES

- Douilles 3/8" 12 pans : 6-7-8-9-10-11-12-13-14-15-16-17-18-19-20-21-22-23-24 mm.
- Douilles longues 3/8" 6 pans : 8-9-10-11-12-13-14-15-17-19 mm.
- Douilles tournevis 6 pans 3/8" : 3-4-5-6-7-8-10 mm.
- Douilles tournevis Torx® 3/8" : T8-T10-T15-T20-T25-T27-T30-T40-T45-T50.
- Douilles tournevis Pozidriv® 3/8" : PZ1-PZ2-PZ3.
- Douilles tournevis Phillips® 3/8" : PH1-PH2-PH3.
- 2 douilles 3/8" pour bougies 16 et 21 mm.
- 1 cliquet parcmètre à verrouillage 3/8".
- 2 rallonges 3/8" : 75-250 mm.
- 1 poignée coulissante 3/8".
- 1 réducteur 1/2" - 3/8".
- 1 cardan universel 3/8".
- Livré en boîte compatible tiroir de servante.



	☑	Quantité	Dimensions	Poids kg	📦	EAN
E031806	3/8"	61	L.415xP.283xH.92 mm	5	1	3258950318066

COFFRET DE DOUILLES 3/8" 12 PANS - MÉTRIQUES - 22 PIÈCES

- Douilles 3/8" 12 pans : 6-7-8-9-10-11-12-13-14-15-16-17-18-19-21-22-24 mm.
- 1 cliquet parcmètre à verrouillage 3/8".
- 2 rallonges 3/8" : 75-125 mm.
- 1 douille 3/8" porte-embout 1/4".
- 1 cardan universel 3/8".
- Livré en boîte compatible tiroir de servante.



	☑	Quantité	Dimensions	Poids kg	📦	EAN
E031805	3/8"	22	L.275xP.186xH.80 mm	1,5	1	3258950318059

COFFRET DE DOUILLES LONGUES 3/8" 6 PANS - MÉTRIQUES - 15 PIÈCES

- Douilles longues 3/8" 6 pans : 7-8-9-10-11-12-13-14-15-16-17-18-19-21-22 mm.
- Livré en boîte compatible tiroir de servante.



	☑	Quantité	Dimensions	Poids kg	📦	EAN
E031804	3/8"	15	L.275xP.186xH.80 mm	1,5	1	3258950318042



MODULE DE DOUILLES ET ACCESSOIRES 3/8" MÉTRIQUES - 50 PIÈCES

- Douilles 3/8" 12 pans : 8-9-10-11-12-13-14-15-16-17-18-19-21-22 mm.
- Douilles longues 3/8" 6 pans : 8-10-11-12-13-14-15-16-17-18-19-21-22 mm.
- Douilles tournevis 6 pans 3/8" : 5-6-8-10-12 mm.
- Douilles tournevis fente 3/8" : 5,5-7-8 mm.
- Douilles tournevis Torx® 3/8" : T25-T27-T30-T40-T45-T50.
- Douilles tournevis Pozidriv® 3/8" : PZ1-PZ2-PZ3.
- Douilles tournevis Phillips® 3/8" : PH1-PH2-PH3.
- 1 rallonge 3/8" : 125 mm.
- 1 cardan 3/8".
- 1 cliquet parcmètre à verrouillage 3/8".
- Plateau vide : E031822.



E031821	3/8"	Quantité	Poids kg	1	EAN
		50	2,8	1	3258950318219

MODULE DE DOUILLES ET ACCESSOIRES 3/8" MÉTRIQUES - 20 PIÈCES

- Douilles 3/8" 12 pans : 7-8-9-10-11-12-13-14-15-16-17-18-19-20-21-22 mm.
- 1 cliquet parcmètre à verrouillage 3/8".
- 2 rallonges 3/8" : 125-250 mm.
- 1 cardan 3/8".
- Plateau vide : E031802.



E194678	3/8"	Quantité	Poids kg	1	EAN
		20	1,5	1	3258951946787

JEU DE DOUILLES 3/8" 6 PANS EN POUÇES - 13 PIÈCES

- Douilles 3/8" 6 pans : 1/4"-5/16"-11/32"-3/8"-7/16"-1/2"-9/16"-5/8"-11/16"-3/4"-13/16"-7/8"-1".
- Livré sur rack métallique.



E031803	3/8"	Quantité	Poids g	1	EAN
		13	850	1	3258950318035





CLIQUETS 3/8"

CLIQUET TÊTE RONDE 3/8"

- ISO 3315 - DIN 3122 - ISO 1174-1
- Mécanisme 72 dents.
- Angle de reprise 5°.
- Tête compacte.
- Finition : chrome brillant.
- Poignée bi-matière ergonomique.

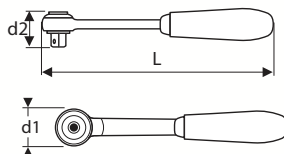

	d1 mm	d2 mm	L mm	Poids g	☒	EAN
E031701	34.5	31.6	199	250	10	3258950317014

CLIQUET PARCÈMETRE À VERROUILLAGE 3/8"

- ISO 3315 - DIN 3122 - ISO 1174-1
- Mécanisme 72 dents.
- Angle de reprise 5°.
- Verrouillage de sécurité de la douille.
- Inversion par levier : visualisation du sens de rotation.
- Finition : chrome brillant.
- Poignée bi-matière ergonomique.
- Kit de réparation disponible: E034902.

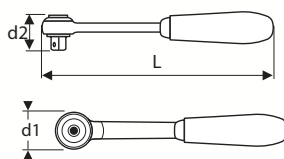

	d1 mm	d2 mm	L mm	Poids g	☒	EAN
E031706	32	29.5	300	285	1	3258950317069

CLIQUET PARCÈMETRE À VERROUILLAGE 3/8" MANCHE MÉTAL

- ISO 3315 - DIN 3122 - ISO 1174-1
- Mécanisme 72 dents.
- Angle de reprise 5°.
- Verrouillage de sécurité de la douille.
- Inversion par levier : visualisation du sens de rotation.
- Finition : chrome brillant.

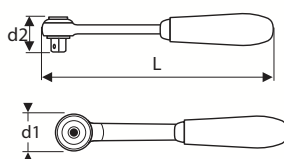
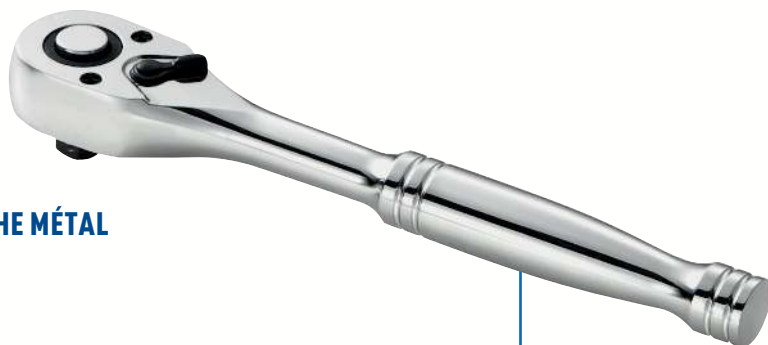

	d1 mm	d2 mm	L mm	Poids g	☒	EAN
E031612	32	30.8	199	322	1	3258950316123





CLIQUET MANCHE ARTICULÉ 3/8"

- ISO 3315 - DIN 3122 - ISO 1174-1
- Mécanisme 72 dents.
- Angle de reprise 5°.
- Manche articulé pour une accessibilité accrue.
- Manche grande longueur pour un desserrage plus puissant.
- Verrouillage de sécurité de la douille.
- Inversion par levier : visualisation du sens de rotation.
- Finition : chrome brillant.
- Poignée bi-matière ergonomique.

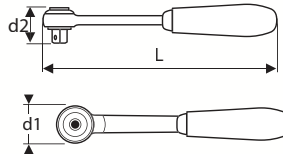
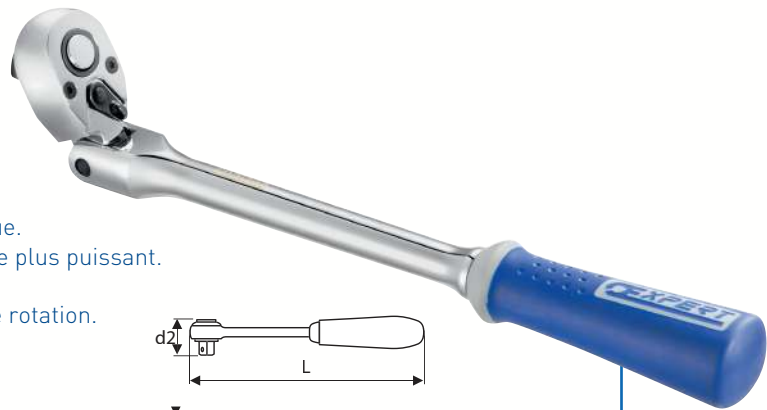

E031702	d1 mm	d2 mm	L mm	Poids g	☒	EAN
E031702	30	31	275	390	1	3258950317021

CLIQUET À TÊTE ARTICULÉE 3/8"

- ISO 3315 - DIN 3122 - ISO 1174-1
- Mécanisme 72 dents.
- Angle de reprise 5°.
- Tête compacte et articulée pour une accessibilité accrue.
- Finition : chrome brillant.
- Poignée bi-matière ergonomique.

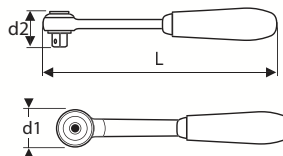
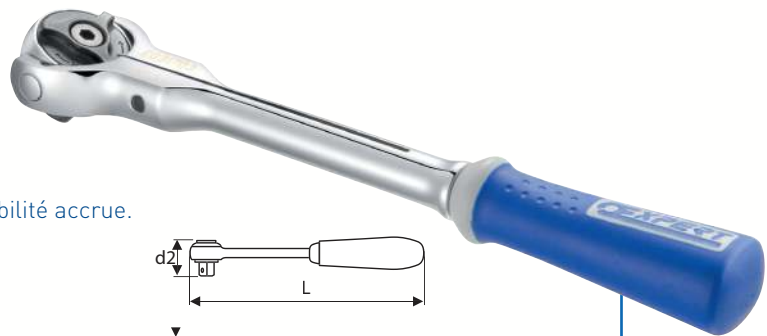

E031703	d1 mm	d2 mm	L mm	Poids g	☒	EAN
E031703	43.6	31.5	234,2	380	1	3258950317038

ACCESSOIRES 3/8"

VILEBREQUIN 3/8"

- ISO 3315 - DIN 3122 - ISO 1174-1
- Grande rapidité de manœuvre.
- Poignée tournante.
- Finition : chrome brillant.



E031604	L mm	Poids g	☒	EAN
E031604	410	395	1	3258950316048





ACCESSOIRES 3/8"

POIGNÉES ARTICULÉES 3/8"

- ISO 3315 - DIN 3122 - ISO 1174-1
- Articulation freinée.
- Manche articulé pour une accessibilité accrue.
- Finition : chrome brillant.
- Poignée bi-matière ergonomique.



	L mm	Poids g	☒	EAN
E031603	375	365	1	3258950316031
E031602	200	211	1	3258950316024

POIGNÉE COULISSANTE 3/8"

- ISO 3315 - DIN 3122 - ISO 1174-1
- Tête coulissante.
- Acier au chrome vanadium.
- Finition : chrome brillant.
- Pour une utilisation manuelle.

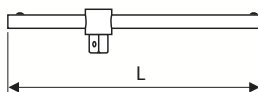

	L mm	Poids g	☒	EAN
E117361	170	128	1	3258951173619

RALLONGES 3/8"

- ISO 3315 - DIN 3122 - ISO 1174-1
- Acier au chrome vanadium.
- Finition: chrome brillant.
- Pour une utilisation manuelle.

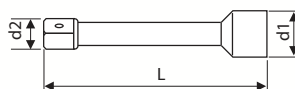
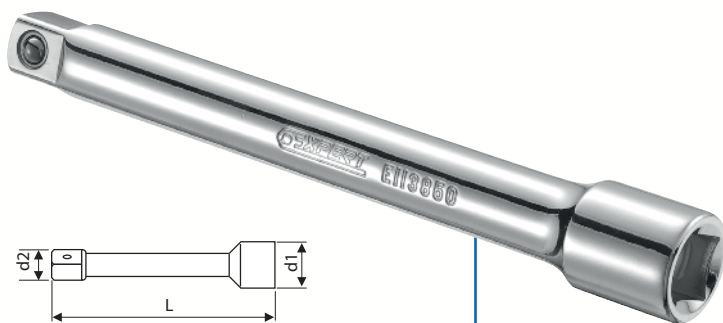

	d1 mm	d2 mm	L mm	Poids g	☒	EAN
E113850	17	12.3	125	120	10	3258951138502
E117363	17	12.3	75	75	10	3258951173633
E117364	17	12.3	250	230	10	3258951173640



RALLONGE FLEXIBLE - 3/8" - 200 MM

- Idéal pour le serrage et desserrage dans des espaces restreints.
- Corps souple.
- Utilisation manuelle (pas d'outils énergisés).

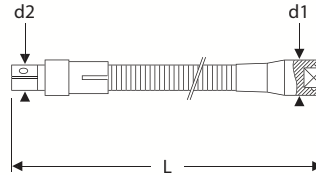
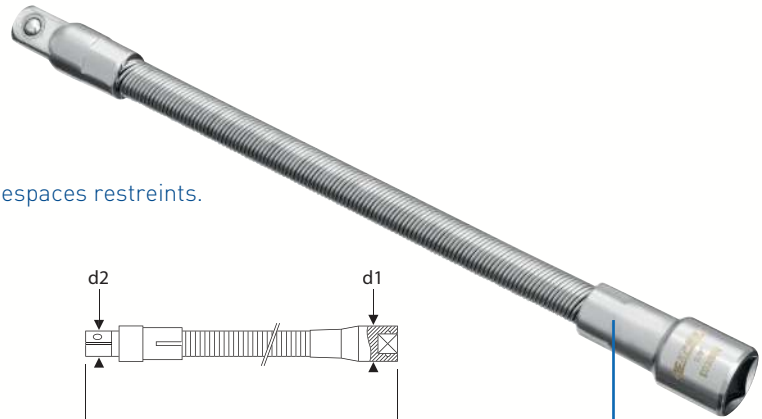

E031614	d1 mm	d2 mm	L mm	Poids g	☒	EAN
E031614	16,2	12,8	200	112	1	3258950316147

DOUILLE 3/8" PORTE-EMBOUS 1/4"

- ISO 1173 - DIN 3126 - ISO 1174-1
- Acier au chrome vanadium.
- Finition : chrome brillant.
- Pour une utilisation manuelle.

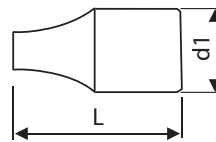

E113851	d1 mm	L mm	Poids g	☒	EAN
E113851	17	25,40	24	1	3258951138519

RÉDUCTEUR 3/8" - 1/4"

- ISO 3316 - DIN 3123 - ISO 1174-1
- Finition : chrome brillant.
- Acier au chrome vanadium.
- Pour une utilisation manuelle.

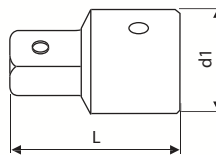

E117365	d1 mm	L mm	Poids g	☒	EAN
E117365	17	25,40	20	1	3258951173657

ADAPTATEUR MAGNÉTIQUE 3/8" - 1/2"

- Utilisation uniquement avec de l'outillage à main.
- Aimanté.
- Livré sur rack métallique.

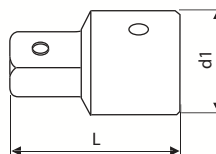

E041506	☒	d1 mm	L mm	Poids g	☒	EAN
E041506	3/8" - 1/2"	25	20	33	1	3258950415062





ACCESSOIRES 3/8"

AUGMENTATEUR 3/8" - 1/2"

- ISO 3316 - DIN 3123 - ISO 1174-1
- Acier au chrome vanadium.
- Finition : chrome brillant.
- Pour une utilisation manuelle.

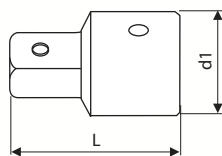

	d1 mm	L mm	Poids g		EAN
E117366	18	36	40	1	3258951173664

CARDAN 3/8"

- ISO 3316 - DIN 3123 - ISO 1174-1
- Acier au chrome vanadium.
- Finition : chrome brillant.
- Pour une utilisation manuelle.

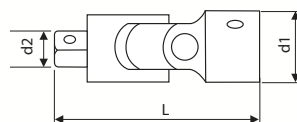

	d1 mm	L mm	Poids g		EAN
E117367	14	29,50	60	10	3258951173671

DOUILLES 3/8"

DOUILLES 3/8" - 12 PANS - MÉTRIQUES

- ISO 2725-1 - DIN 3124 - ISO 1174-1 - ISO 1711-1 - ISO 691
- Acier au chrome vanadium.
- Profil Maxi Drive : transmission du couple de serrage sur les flancs de l'écrou et non sur les arêtes.
- Finition : chrome brillant.
- Pour une utilisation manuelle.

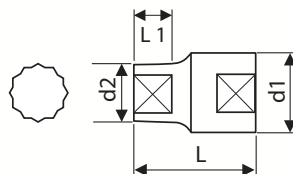

	A mm	d1 mm	d2 mm	L mm	L1 mm	Poids g		EAN
E030933	6	17,1	10,1	25,70	5	18	10	3258950309330
E113830	7	17,1	10,8	25,70	6	18	10	3258951138304
E113831	8	17,1	12	25,70	6	20	10	3258951138311
E113832	9	17,1	13,1	25,70	6,5	20	10	3258951138328
E113833	10	17,1	14,7	25,70	7	20	10	3258951138335
E113834	11	17,1	16	25,70	8	22	10	3258951138342
E113835	12	17,1	17,1	25,70	8,5	22	10	3258951138359
E113836	13	18,3	18,3	25,70	8,5	28	10	3258951138366
E113837	14	19,5	19,5	25,70	10	30	10	3258951138373
E113838	15	20,4	20,4	25,70	10	33	10	3258951138380
E113839	16	22,1	22,1	25,70	10	46	10	3258951138397
E113840	17	23,3	23,3	25,70	10	52	10	3258951138403
E113841	18	24,2	24,2	25,70	11	56	10	3258951138410
E113842	19	25,5	25,5	25,70	12	64	10	3258951138427
E113843	20	26,8	26,8	29	14	68	10	3258951138434
E113844	21	27,7	27,7	29	14	72	10	3258951138441
E113845	22	29,8	29,8	29	14	86	10	3258951138458
E113846	23	30,8	30,8	29	14	90	10	3258951138465
E113847	24	31,8	31,8	29	14	96	10	3258951138472



DOUILLES 3/8" - 6 PANS - MÉTRIQUES

- ISO 2725-1 - DIN 3124 - ISO 1174-1 - ISO 1711-1 - ISO 691
- Acier au chrome vanadium.
- Profil Maxi Drive : transmission du couple de serrage sur les flancs de l'écrou et non sur les arêtes.
- Finition : chrome brillant.
- Pour une utilisation manuelle.

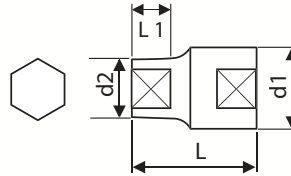

	A mm	d1 mm	d2 mm	L mm	L1 mm	Poids g	☒	EAN
E030935	6	17,1	10,1	25,70	5	18	10	3258950309354
E030936	7	17,1	10,8	25,70	6	18	10	3258950309361
E030937	8	17,1	12	25,70	6	20	10	3258950309378
E030938	9	17,1	13,1	25,70	6,5	20	10	3258950309385
E030939	10	17,1	14,7	25,70	7	20	10	3258950309392
E030940	11	17,1	16	25,70	8	22	10	3258950309408
E030941	12	17,1	17,1	25,70	8,5	22	10	3258950309415
E030942	13	18,3	18,3	25,70	8,5	28	10	3258950309422
E030943	14	19,5	19,5	25,70	10	30	10	3258950309439
E030944	15	20,4	20,4	25,70	10	33	10	3258950309446
E030945	16	22,1	22,1	25,70	10	46	10	3258950309453
E030946	17	23,3	23,3	25,70	10	52	10	3258950309460
E030947	18	24,2	24,2	25,70	11	56	10	3258950309477
E030948	19	25,5	25,5	25,70	12	64	10	3258950309484
E030949	20	26,8	26,8	29	14	68	10	3258950309491
E030950	21	27,7	27,7	29	14	72	10	3258950309507
E030951	22	29,8	29,8	29	14	86	10	3258950309514
E030952	23	30,8	30,8	29	14	90	10	3258950309521
E030953	24	31,8	31,8	29	14	96	10	3258950309538

DOUILLES 3/8" - 6 PANS - POUÇES

- ASME B 107-1 - ISO 1174-1
- Acier au chrome vanadium.
- Profil Maxi Drive : transmission du couple de serrage sur les flancs de l'écrou et non sur les arêtes.
- Finition : chrome brillant.
- Pour une utilisation manuelle.

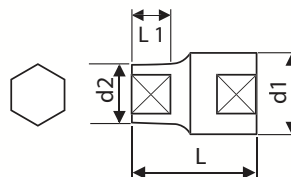

	A "	d1 mm	d2 mm	L mm	L1 mm	Poids g	☒	EAN
E031301	1/4"	17,1	10	25,70	3,2	24	10	3258950313016
E031302	5/16"	17,1	11,7	25,70	4,5	25	10	3258950313023
E031303	11/32"	17,1	13	25,70	5	25	10	3258950313030
E031304	3/8"	17,1	14,2	25,70	5	26	10	3258950313047
E031305	7/16"	17,1	16,3	25,70	7	27	10	3258950313054
E031306	1/2"	18,3	18,3	25,70	7	36	10	3258950313061
E031307	9/16"	19,5	19,5	25,70	9	34	10	3258950313078
E031308	5/8"	22,1	22,1	25,70	10	45	10	3258950313085
E031309	11/16"	24,2	24,2	25,70	10	56	10	3258950313092
E031310	3/4"	25,7	25,7	25,70	12	67	10	3258950313108
E031311	13/16"	27,7	27,7	29	13	74	10	3258950313115
E031312	7/8"	29,8	29,8	29	13	91	10	3258950313122
E031334	15/16"	31,8	31,8	29	13	102	1	3258950313344
E031313	1"	33,2	33,2	35	14	123	10	3258950313139





DOUILLES 3/8"

DOUILLES LONGUES 3/8" - 6 PANS - MÉTRIQUES

- ISO 2725-1 - DIN 3124 - ISO 1174-1 - ISO 1711-1 - ISO 691
- Acier au chrome vanadium.
- Profil Maxi Drive : transmission du couple de serrage sur les flancs de l'écrou et non sur les arêtes.
- Finition : chrome brillant.
- Pour une utilisation manuelle.

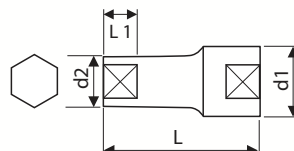

	A mm	d1 mm	d2 mm	L mm	L1 mm	Poids g	☒	EAN
E031502	7	16,5	12	45,5	12	46	10	3258950315027
E031503	8	16,5	12	45,50	12	46	10	3258950315034
E031504	9	16,5	13,1	45,50	14	47	10	3258950315041
E031505	10	16,5	14,7	45,50	15	50	10	3258950315058
E031506	11	16,5	16	45,50	17	53	10	3258950315065
E031507	12	17,1	17,1	45,50	18	53	10	3258950315072
E031508	13	18,5	18,5	45,50	18	54	10	3258950315089
E031509	14	19,5	19,5	50	18	60	10	3258950315096
E031510	15	20,4	20,4	53	20	75	10	3258950315102
E031511	16	22	22	53	20	85	10	3258950315119
E031512	17	23,3	23,3	56	20	102	10	3258950315126
E031513	18	24,2	24,2	56	20	109	10	3258950315133
E031514	19	25,5	25,5	56	20	110	10	3258950315140
E031105	20	26,8	26,8	63,50	22	117	10	3258950311050
E031501	21	27,7	27,7	63,50	22	123	10	3258950315010
E031515	22	29,8	29,8	63,50	22	150	10	3258950315157

DOUILLES LONGUES 3/8" - 6 PANS - POUCES

- ASME B 107-1 - ISO 1174-1
- Acier au chrome vanadium.
- Profil Maxi Drive : transmission du couple de serrage sur les flancs de l'écrou et non sur les arêtes.
- Finition : chrome brillant.
- Pour une utilisation manuelle.

	A "	d1 mm	d2 mm	L mm	L1 mm	Poids g	☒	EAN
E031525	1/4"	16,5	9,8	45,5	10	44	10	3258950315256
E031526	5/16"	16,5	11,7	45,5	12	46	10	3258950315263
E031516	3/8"	16,5	14,2	45,5	15	51	10	3258950315164
E031517	7/16"	16,5	16,5	45,5	17	53	10	3258950315171
E031518	1/2"	18,5	18,5	45,5	18	54	10	3258950315188
E031519	9/16"	19,5	19,5	50	18	60	10	3258950315195
E031520	5/8"	22	22	53	20	85	10	3258950315201
E031521	11/16"	24,2	24,2	56	20	109	10	3258950315218
E031522	3/4"	25,7	25,7	56	22	110	10	3258950315225
E031523	13/16"	27,7	27,7	63,5	22	123	10	3258950315232
E031524	7/8"	29,8	29,8	63,5	22	150	10	3258950315249
E031527	15/16"	31,8	31,8	63,5	22	152	10	3258950315270
E031528	1"	33,8	33,8	63,5	22	155	10	3258950315287





DOUILLES TORX® 3/8"

DOUILLES TORX® 3/8"

- ISO 1174-1
- Pour vis mâles Torx®.
- Acier au chrome vanadium.
- Finition : chrome brillant.

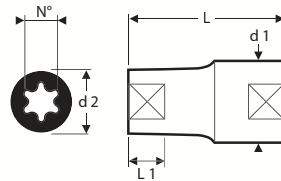

	N°	d1 mm	d2 mm	L mm	Poids g	📦	EAN
E030928	E10	17,1	12,5	29	40	10	3258950309286
E030929	E12	17,1	14,2	29	40	10	3258950309293
E030930	E14	17,1	16	29	50	10	3258950309309
E030931	E16	18,3	17,5	29	100	10	3258950309316

DOUILLES TOURNEVIS 3/8"

JEU DE DOUILLES TOURNEVIS TORX® 3/8" - 4 PIÈCES

- Douilles tournevis Torx® 3/8" : T40-T45-T50-T55.
- Livré sur rack métallique.



	Quantité	Poids g	📦	EAN
E031807	4	150	10	3258950318073

DOUILLES TOURNEVIS 3/8" POUR VIS 6 PANS CREUX

- ISO 2725-1 - DIN3124 - ISO 1174-1
- Acier au chrome vanadium.
- Finition : chrome brillant.

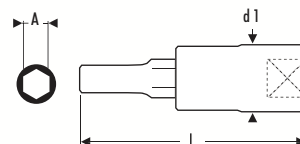

	A mm	d1 mm	L mm	Poids g	📦	EAN
E030901	3	17,9	50	30	10	3258950309019
E030902	4	17,9	50	31	10	3258950309026
E030903	5	17,9	50	32	10	3258950309033
E030904	6	17,9	50	33	10	3258950309040
E030905	7	17,9	50	34	10	3258950309057
E030906	8	17,9	50	43	10	3258950309064
E030934	9	17,9	50	47	10	3258950309347
E030907	10	17,9	50	50	10	3258950309071
E030908	12	22	50	58	10	3258950309088





DOUILLES TOURNEVIS 3/8"

DOUILLES TOURNEVIS 3/8" POUR VIS À FENTE

- ISO 2725-1 - DIN3124 - ISO 1174-1
- Acier au chrome vanadium.
- Finition : chrome brillant.

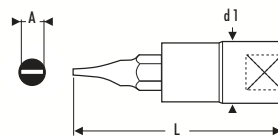

	A mm	d1 mm	L mm	Poids g		EAN
E030909	5,5	17,9	50	33	10	3258950309095
E030910	7	17,9	50	34	10	3258950309101
E030911	8	17,9	50	43	10	3258950309118

DOUILLES TOURNEVIS 3/8" POUR VIS PHILLIPS®

- ISO 2725-1 - DIN3124 - ISO 1174-1
- Acier au chrome vanadium.
- Finition : chrome brillant.

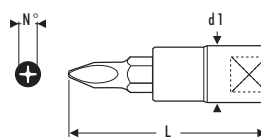

	N°	d1 mm	L mm	Poids g		EAN
E030925	PH1	17,9	50	31	10	3258950309255
E030926	PH2	17,9	50	33	10	3258950309262
E030927	PH3	17,9	50	43	10	3258950309279

DOUILLES TOURNEVIS 3/8" POUR VIS POZIDRIV®

- ISO 2725-1 - DIN3124 - ISO 1174-1
- Acier au chrome vanadium.
- Finition : chrome brillant.

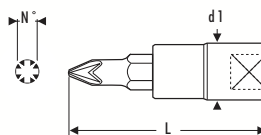

	N°	d1 mm	L mm	Poids g		EAN
E030922	PZ1	17,9	50	31	10	3258950309224
E030923	PZ2	17,9	50	33	10	3258950309231
E030924	PZ3	17,9	50	43	10	3258950309248

DOUILLES TOURNEVIS 3/8" POUR VIS TORX®

- ISO 1174-1
- Acier au chrome vanadium.
- Finition : chrome brillant.

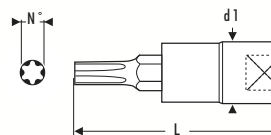

	N°	d1 mm	L mm	Poids g		EAN
E030912	T8	17,9	50	33,5	10	3258950309125
E030913	T10	17,9	50	33,5	10	3258950309132
E030914	T15	17,9	50	33,5	10	3258950309149
E030915	T20	17,9	50	33,5	10	3258950309156
E030916	T25	17,9	50	33,5	10	3258950309163
E030917	T27	17,9	50	33,5	10	3258950309170
E030918	T30	17,9	50	33,5	10	3258950309187
E030919	T40	17,9	50	45	10	3258950309194
E030932	T45	17,9	50	45	10	3258950309323
E030920	T50	17,9	50	48	10	3258950309200
E030921	T55	17,9	50	61	10	3258950309217



COMPOSITIONS DE DOUILLES ET ACCESSOIRES 1/2"

COFFRET DE DOUILLES ET ACCESSOIRES 1/2" MIXTE - 55 PIÈCES

- Douilles 1/2" 6 pans : 8-9-10-11-12-13-14-15-16-17-18-19-20-21-22-23-24-25-26-27-28-29-30-32-34 mm.
- Douilles 1/2" 12 pans : 3/8"-7/16"-1/2"-9/16"-5/8"-11/16"-3/4"-13/16"-7/8"-15/16"-1"-1 1/16"-1 1/8"-1 3/16"-1 1/4".
- Douilles Torx® 1/2" : E10-E11-E12-E14-E16-E18-E20-E24.
- 1 cliquet parcmètre à verrouillage 1/2".
- 2 rallonges 1/2" : 130-250 mm.
- 1 poignée coulissante 1/2".
- 1 cardan 1/2".
- 1 réducteur 1/2" - 3/8".
- 1 augmentateur 3/8" - 1/2".
- Livré en boîte compatible tiroir de servante.



E032909	1/2"	Quantité	Dimensions	Poids kg	1	EAN
		55	L.415xP.283xH.92 mm	6,5		3258950329093



COFFRET DE DOUILLES ET ACCESSOIRES 1/2" MÉTRIQUES - 42 PIÈCES

- Douilles 1/2" 6 pans : 8-9-10-11-12-13-14-15-16-17-18-19-20-21-22-23-24-25-26-27-28-29-30-32 mm.
- Douilles longues 1/2" 6 pans : 12-13-14-15-16-17-18-19-21-22-24 mm.
- 2 rallonges 1/2" : 130-250 mm.
- 1 poignée coulissante 1/2".
- 1 cardan 1/2".
- 1 réducteur 1/2" - 3/8".
- 1 augmentateur 3/8" - 1/2".
- 1 cliquet parcmètre à verrouillage 1/2".
- Livré en boîte compatible tiroir de servante.



E032908	1/2"	Quantité	Dimensions	Poids kg	1	EAN
		42	L.415xP.283xH.92 mm	5,5		3258950329086



COFFRET DE DOUILLES ET ACCESSOIRES 1/2" MÉTRIQUES - 22 PIÈCES

- Douilles 1/2" 6 pans : 8-10-11-12-13-14-15-16-17-18-19-21-22-24-27-30-32 mm.
- 1 cliquet parcmètre à verrouillage 1/2".
- 1 poignée coulissante 1/2".
- 2 rallonges 1/2" : 130-250 mm.
- 1 cardan 1/2".
- Livré en boîte à fermoirs métalliques, compatible tiroir de servante.



E032900	1/2"	Quantité	Dimensions	Poids kg	1	EAN
		22	L.275xP.186xH.92 mm	4		3258950329000





COMPOSITIONS DE DOUILLES ET ACCESSOIRES 1/2"

JEU DE DOUILLES 1/2" MÉTRIQUES - 16 PIÈCES

- Douilles 1/2" 6 pans : 10-11-12-13-14-15-16-17-18-19-21-22-24-27-30-32 mm.
- Livré sur rack métallique.



E032902	1/2"	Quantité	Poids kg	☒	EAN
		16	1,7	1	3258950329024



RACK DE 10 DOUILLES 1/2" MÉTRIQUES

- Douilles 1/2" 6 pans : 9-10-11-12-13-14-15-17-18-19 mm.
- Livré sur rack métallique.



E034837	1/4"	Quantité	Poids kg	☒	EAN
		10	0,715	1	3258950348377



COMPOSITIONS DE DOUILLES ET DOUILLES TOURNEVIS 1/2"

COFFRET DE DOUILLES ET DOUILLES TOURNEVIS TORX® 1/2" - 16 PIÈCES

- Douilles tournevis Torx® 1/2" : T20-T25-T27-T30-T40-T45-T50-T55-T60.
- Douilles Torx® 1/2" : E10-E12-E14-E16-E18-E20-E24.
- Livré en boîte compatible tiroir de servante.



E032907	1/2"	Quantité	Dimensions	Poids kg	☒	EAN
		16	L.275xP.186xH.92 mm	1,65	1	3258950329079



COFFRET DE DOUILLES TOURNEVIS TORX® 1/2" - 32 PIÈCES

- Douilles tournevis 1/2" Torx® :
 - L.55 mm : T20-T25-T27-T30-T40-T45-T50-T55-T60-T70.
 - L.100 mm : T20-T25-T27-T30-T40-T45-T50-T55-T60-T70.
 - L.140 mm : T40-T45-T50-T55-T60-T70.
 - L.200 mm : T40-T45-T50-T55-T60-T70.
- Livré en boîte compatible tiroir de servante.



E200514	1/2"	Quantité	Dimensions	Poids kg	☒	EAN
		32	L.415 x P.314 x H.92 mm	5,15	1	3258952005148





COFFRET DE DOUILLES TOURNEVIS 6 PANS 1/2" - 30 PIÈCES

- Douilles tournevis 1/2" 6 pans :
 L.55 mm : 5-6-7-8-10-12-14-17-19 mm.
 L.100 mm : 5-6-7-8-10-11-12-13 mm.
 L.140 mm : 5-6-7-8-10-12-14 mm.
 L.200 mm : 5-6-7-8-10-12 mm.
- Livré en boîte compatible tiroir de servante.



E200516	1/2"	Quantité	Dimensions	Poids kg	☒	EAN
E200516	1/2"	30	L.415 x P.314 x H.92 mm	5	1	3258952005162



COFFRET DE DOUILLES TOURNEVIS 1/2" CRÉNEAUX - 32 PIÈCES

- Douilles tournevis 1/2" créneaux :
 L.55 mm : M5, M6, M7, M8, M9, M10, M12, M13, M14.
 L.100 mm : M5, M6, M7, M8, M9, M10, M12, M13, M14.
 L.140 mm : M8, M9, M10, M10,3, M12, M13, M14.
 L.200 mm : M8, M9, M10, M10,3, M12, M13, M14.



E200522	1/2"	Quantité	Dimensions	Poids kg	☒	EAN
E200522	1/2"	32	L.415 x P.314 x H.92 mm	5	1	3258952005223



COFFRET DE DOUILLES TOURNEVIS XZN® 1/2" - 26 PIÈCES

- Douilles tournevis 1/2" XZN® :
 L.55 mm : M5-M6-M8-M9-M10-M12-M14-M16.
 L.100 mm : M5-M6-M8-M9-M10-M12-M14.
 L.140 mm : M5-M6-M8-M9-M10-M12-M14.
 L.200 mm : M8-M10-M12-M14-M16.
- Livré en boîte compatible tiroir de servante.



E200515	1/2"	Quantité	Dimensions	Poids kg	☒	EAN
E200515	1/2"	26	L.415 x P.314 x H.92 mm	4,4	1	3258952005155





COMPOSITIONS DE DOUILLES ET DOUILLES TOURNEVIS 1/2"

COFFRET DE DOUILLES TOURNEVIS 6 PANS 1/2" - 13 PIÈCES

- Douilles tournevis 1/2" 6 pans : 4-5-6-8-9-10-12 mm.
- Douilles tournevis longues 1/2" 6 pans : 4-5-6-8-10-12 mm.
- Livré en boîte compatible tiroir de servante.



		Quantité	Dimensions	Poids kg		EAN
E032906	1/2"	13	L.275xP.186xH.92 mm	1,8	1	3258950329062



JEU DE DOUILLES TOURNEVIS 1/2" 6 PANS - 8 PIÈCES

- Douilles tournevis 1/2" 6 pans : 6-7-8-9-10-12-14-17 mm.
- Livré sur rack métallique.



		Quantité	Poids g		EAN
E032904	1/2"	8	750	1	3258950329048



JEU DE DOUILLES LONGUES TOURNEVIS 6 PANS 1/2" - 6 PIÈCES

- Douilles longues tournevis 1/2" 6 pans : 4-5-6-8-10-12 mm, L.90mm.
- Livré sur rack métallique.



		Quantité	Poids g		EAN
E032941	1/2"	6	900	1	3258950329413



JEU DE DOUILLES TOURNEVIS TORX® 1/2" - 9 PIÈCES

- Douilles tournevis Torx® 1/2" 6 pans : T20-T25-T27-T30-T40-T45-T50-T55-T60, L.55mm.
- Livré sur rack métallique.



		Quantité	Poids g		EAN
E032936	1/2"	9	696	1	3258950329369





MODULE DE DOUILLES TOURNEVIS ET DOUILLES TORX® 1/2" - 33 PIÈCES

- Douilles tournevis 1/2" 6 pans : 5-6-7-8-9-10-12-14-17 mm.
- Douilles tournevis longues 1/2" 6 pans : 4-5-6-8-10-12 mm.
- Douilles tournevis Torx® 1/2" : T20-T25-T27-T30-T40-T45-T50-T55-T60.
- Douilles Torx® 1/2" : E10-E11-E12-E14-E16-E18-E20-E22-E24.
- Plateau vide : E032923.



E032922	1/2"	Quantité	Poids g	☒	EAN
		33	2725	1	3258950329222



MODULE DE DOUILLES ET ACCESSOIRES 1/2" MÉTRIQUES - 21 PIÈCES

- Douilles 1/2" 6 pans : 8-10-11-12-13-14-15-16-17-18-19-21-22-23-24-27-30-32 mm.
- 1 cliquet parcmètre à verrouillage 1/2".
- 1 rallonge 1/2" : 250 mm.
- 1 cardan 1/2".
- Plateau vide : E032901.



E194677	1/2"	Quantité	Poids kg	☒	EAN
		21	3,5	1	3258951946770



MODULE DE DOUILLES LONGUES 1/2" MÉTRIQUES - 10 PIÈCES

- Douilles longues 1/2" 6 pans : 10 mm.
- Douilles longues 1/2" 12 pans : 12-13-14-17-19-21-22-23-24 mm.
- Plateau vide : E010515.



E032201	1/2"	Quantité	Poids g	☒	EAN
		10	1968	1	3258950322018



MODULE D'ACCESSOIRES 1/2" MÉTRIQUES - 8 PIÈCES

- 3 rallonges 1/2" : 75-130-250 mm.
- 1 cliquet tête articulée 1/2".
- 1 poignée coulissante 1/2".
- 1 douille 1/2" porte-embout 5/16".
- 1 réducteur 1/2" - 3/8".
- 1 augmentateur 1/2" - 3/4".
- Plateau vide : E032925.

E032924	1/2"	Quantité	Poids g	☒	EAN
		8	2150	1	3258950328010





COMPOSITIONS DE DOUILLES ET DOUILLES TOURNEVIS 1/2"

COFFRET DE DOUILLES 1/2" - 36 PIÈCES

- Douilles 1/2" 6 pans : 8-9-10-11-12-13-14-15-16-17-18-19-21-24-27-28-30-32-34 mm.
- Douilles tournevis 6 pans : 5-6-10-12-14 mm.
- Clés à fourches métriques : 6x7 - 8x9 - 10x11 - 12x13 - 14x15 - 16x17 - 18x19 mm.
- 1 cliquet parcmètre à verrouillage 1/2".
- 2 rallonges 1/2" : 130-250 mm.
- 1 poignée coulissante 1/2".
- 1 cardan 1/2".



E032940	1/2"	Quantité	Poids kg	☒	EAN
		36	6,1	1	3258950329406



COFFRET DE DOUILLES 1/2" - 28 PIÈCES

- Douilles 1/2" 6 pans : 8-9-10-11-12-13-14-15-16-17-18-19-20-21-22-23-24-25-26-27-28-30-32-34 mm.
- 1 cliquet parcmètre à verrouillage 1/2".
- 1 poignée coulissante 1/2".
- 1 cardan 1/2".
- 1 rallonge 1/2" : 250 mm.



E032939	1/2"	Quantité	Poids kg	☒	EAN
		28	5,3	1	3258950329390



COFFRET DE DOUILLES 1/2" - 26 PIÈCES

- Douilles 1/2" 6 pans : 10-11-12-13-14-15-16-17-18-19-20-21-22-23-24-27-28-30-34 mm.
- 1 cliquet tête ronde 1/2".
- 2 rallonges 1/2" : 130-250 mm.
- 1 poignée coulissante 1/2".
- 1 cardan 1/2".
- 1 vilebrequin 1/2".
- 1 douille à bougie 1/2" : 21 mm.



E032943	1/2"	Quantité	Poids kg	☒	EAN
		26	6	1	3258950329437





COFFRET DE DOUILLES 1/2" - 25 PIÈCES

- Douilles 1/2" 6 pans : 8-9-10-11-12-13-14-16-17-18-19-21-24-27-30-32 mm.
- Clés à fourches métriques : 6x7 - 8x9 - 10x11 - 12x13 - 14x15 - 16x17 - 18x19 mm.
- 1 cliquet tête ronde 1/2".
- 1 rallonge 1/2" : 130 mm.



E032937	1/2"	Quantité	Poids kg	1	EAN
		25	3,9	1	3258950329376



COFFRET DE DOUILLES 1/2" - 14 PIÈCES

- Douilles 1/2" 6 pans : 10-11-12-13-16-18-21-24-27-30-34 mm.
- 1 cliquet tête ronde 1/2".
- 1 rallonge 1/2" : 250 mm.
- 1 poignée coulissante 1/2".



E032938	1/2"	Quantité	Poids kg	1	EAN
		14	3,1	1	3258950329383



JEU DE DOUILLES SUR RACK 1/2" - 18 PIÈCES

- Douilles 1/2" 6 pans : 8-9-10-11-12-13-14-15-16-17-18-19-20-21-22-23 mm.
- 1 cliquet parcmètre à verrouillage 1/2".
- 1 rallonge 1/2" : 130 mm.
- Livré sur rack.



E032942	1/2"	Quantité	Poids kg	1	EAN
		18	1,8	1	3258950329420





CLIQUETS 1/2"

CLIQUET TÊTE RONDE 1/2"

- ISO 3315 - DIN 3122 - ISO 1174-1
- Mécanisme 72 dents.
- Angle de reprise 5°.
- Tête compacte.
- Finition : chrome brillant.
- Poignée bi-matière ergonomique.



E032801	d1 mm	d2 mm	L mm	Poids g	☒	EAN
E032801	42,4	42	250	490	1	3258950328010

CLIQUET PARCÈMÈTRE À VERROUILLAGE 1/2"

- ISO 3315 - DIN 3122 - ISO 1174-1
- Mécanisme 72 dents.
- Angle de reprise 5°.
- Verrouillage de sécurité de la douille.
- Inversion par levier : visualisation du sens de rotation.
- Finition : chrome brillant.
- Poignée bi-matière ergonomique.
- Kit de réparation disponible: E034903.



E032808	d1 mm	d2 mm	L mm	Poids g	☒	EAN
E032808	38	36,8	250	528	1	3258950328009

CLIQUET PARCÈMÈTRE À VERROUILLAGE 1/2" MANCHE MÉTAL

- ISO 3315 - DIN 3122 - ISO 1174-1
- Mécanisme 72 dents.
- Angle de reprise 5°.
- Verrouillage de sécurité de la douille.
- Inversion par levier : visualisation du sens de rotation.
- Finition : chrome brillant.

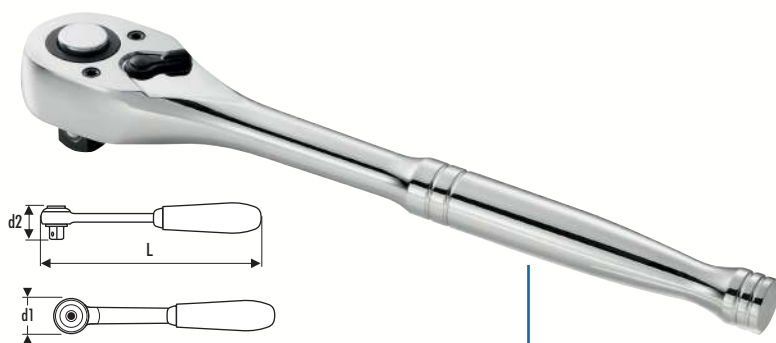

E032709	d1 mm	d2 mm	L mm	Poids g	☒	EAN
E032709	39,2	39	250	588	1	3258950327099



CLIQUET MANCHE ARTICULÉ 1/2"

- ISO 3315 - DIN 3122 - ISO 1174-1
- Mécanisme 72 dents.
- Angle de reprise 5°.
- Manche articulé pour une accessibilité accrue.
- Manche grande longueur pour un desserrage plus puissant.
- Verrouillage de sécurité de la douille.
- Inversion par levier : visualisation du sens de rotation.
- Finition : chrome brillant.
- Poignée bi-matière ergonomique.

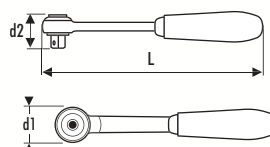

	d1 mm	d2 mm	L mm	Poids g		EAN
E032803	40	40	437	930	1	3258950328034

CLIQUET TÊTE ARTICULÉE 1/2"

- ISO 3315 - DIN 3122 - ISO 1174-1
- Mécanisme 72 dents.
- Angle de reprise 5°.
- Tête compacte.
- Finition : chrome brillant.
- Poignée bi-matière ergonomique.

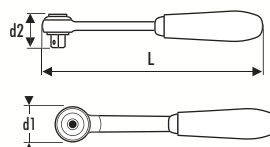
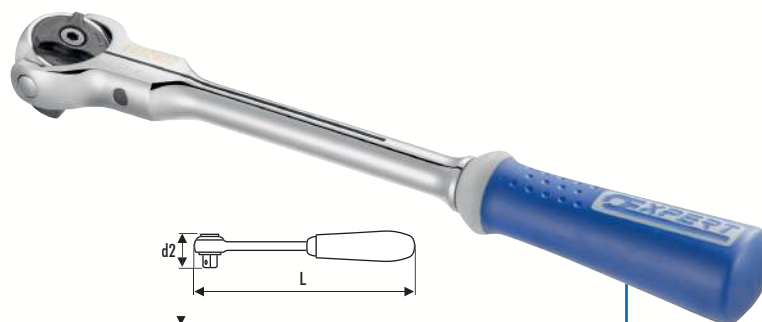

	d1 mm	d2 mm	L mm	Poids g		EAN
E032802	49,1	39,2	306	640	1	3258950328027

POIGNÉES ARTICULÉES 1/2"

- ISO 3315 - DIN 3122 - ISO 1174-1
- Articulation freinée.
- Manche articulé pour une accessibilité accrue.
- Finition : chrome brillant.
- Poignée bi-matière ergonomique.



	L mm	Poids g		EAN
E032701	300	560	1	3258950327013
E032804	450	860	1	3258950328041
E032805	600	1120	1	3258950328058





ACCESSOIRES 1/2"

VILEBREQUIN 1/2"

- ISO 3315 - DIN 3122 - ISO 1174-1
- Grande rapidité de manœuvre.
- Poignée tournante.
- Finition : chrome brillant.



	L mm	Poids g		EAN
E032702	425	510	1	3258950327020

POIGNÉE COUDÉE 1/2"

- ISO 1174 - DIN 3122
- Finition : chrome mat.



	L mm	Poids g		EAN
E032713	200	280	1	3258950327136

POIGNÉE COUDÉE AVEC MANCHE 1/2"

- ISO 1174 - DIN 3122
- Poignée bi-matière ergonomique.
- Finition : chrome mat.

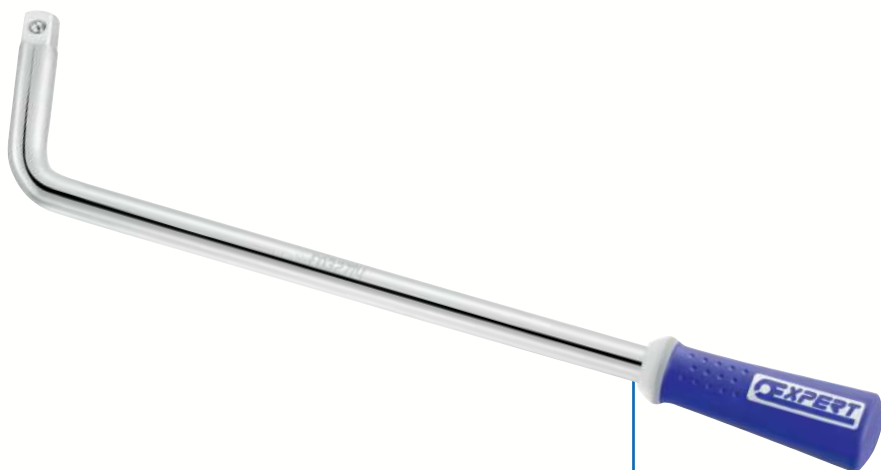

	L mm	Poids g		EAN
E032714	400	691	1	3258950327143



POIGNÉE COULISSANTE 1/2"

- ISO 3315 - DIN 3122 - ISO 1174-1
- Tête coulissante.
- Acier au chrome vanadium.
- Pour une utilisation manuelle.



	L mm	Poids g	📦	EAN
E117259	240	316	1	3258951172599

RALLONGES 1/2"

- ISO 3315 - DIN 3122 - ISO 1174-1
- Acier au chrome vanadium.
- Finition: chrome brillant.
- Pour une utilisation manuelle.

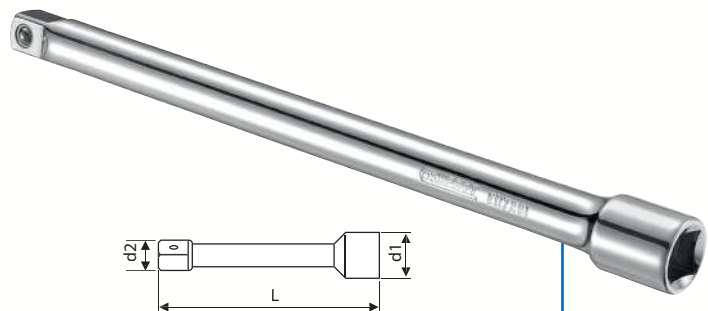

	d1 mm	d2 mm	L mm	Poids g	📦	EAN
E113710	22.5	12.7	75	125	1	3258951137109
E117260	22.5	12.7	130	220	1	3258951172605
E117261	22.5	12.7	250	405	1	3258951172612

RALLONGE FLEXIBLE - 1/2" - 200 MM

- Idéal pour le serrage et desserrage dans des espaces restreints.
- Corps souple.
- Utilisation manuelle (pas d'outils énergisés).



	Poids g	📦	EAN
E032711	212	1	3258950327112





ACCESSOIRES 1/2"

DOUILLE 1/2" PORTE-EMBOUS 5/16"

- ISO 1173 - DIN 3126 - ISO 1174-1
- Acier au chrome vanadium.
- Finition : chrome brillant.
- Pour une utilisation manuelle.

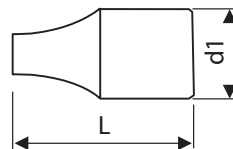

	d1 mm	d2 mm	L mm	Poids g	☒	EAN
E113711	25	12.7	40	90	5	3258951137116

RÉDUCTEUR 1/2" - 3/8"

- ISO 3316 - DIN 3123 - ISO 1174-1
- Acier au chrome vanadium.
- Finition : chrome brillant.
- Pour une utilisation manuelle.

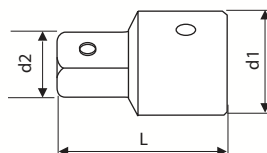

	d1 mm	d2 mm	L mm	Poids g	☒	EAN
E117262	22	12.7	34,5	46	1	3258951172629

AUGMENTATEUR 1/2" - 3/4"

- ISO 3316 - DIN 3123 - ISO 1174-1
- Acier au chrome vanadium.
- Finition : chrome brillant.
- Pour une utilisation manuelle.

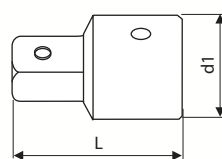

	d1 mm	d2 mm	L mm	Poids g	☒	EAN
E117263	25.2	12.7	42	75	5	3258951172636

ADAPTATEUR MAGNÉTIQUE 1/2" - 3/4"

- Utilisation uniquement avec de l'outillage à main.
- Aimanté.
- Livré sur rack métallique.



	☒	L mm	Poids g	☒	EAN
E041507	1/2" - 3/4"	25,5	74	1	3258950415079



CARDAN 1/2"

- ISO 3316 - DIN 3123 - ISO 1174-1
- Acier au chrome vanadium.
- Finition : chrome brillant.
- Pour une utilisation manuelle.

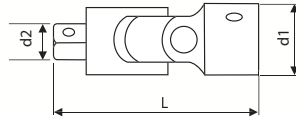

	d1 mm	d2 mm	L mm	Poids g	☒	EAN
E117264	24,9	12,7	40,5	140	1	3258951172643



DOUILLES 1/2"

DOUILLES 1/2" - 6 PANS - MÉTRIQUES

- ISO 2725-1 - DIN 3124 - ISO 1174-1 - ISO 1711-1 - ISO 691
- Acier au chrome vanadium.
- Profil Maxi Drive : transmission du couple de serrage sur les flancs de l'écrou et non sur les arêtes.
- Finition chrome brillant.
- Pour une utilisation manuelle.

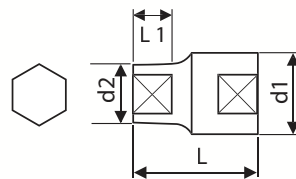

	A mm	d1 mm	d2 mm	L mm	L1 mm	Poids g	☒	EAN
E117086	8	21,8	12,4	38	9	45	1	3258951170861
E117087	9	21,8	14	38	10	45	1	3258951170878
E117088	10	21,8	15,5	38	10	48	1	3258951170885
E117089	11	21,8	16,7	38	11	50	1	3258951170892
E117090	12	21,8	18	38	10	50	1	3258951170908
E117091	13	21,8	19,2	38	10	52	1	3258951170915
E117092	14	21,8	20,5	38	10	54	1	3258951170922
E117093	15	21,8	21	38	14	54	1	3258951170939
E117094	16	23,3	22,5	38	14	66	1	3258951170946
E117095	17	24	24	38	14	76	1	3258951170953
E117096	18	24,8	24,8	38	14	84	1	3258951170960
E117097	19	26,3	26,3	38	16,7	84	1	3258951170977
E117098	20	26,8	26,8	38	17,3	84	1	3258951170984
E117099	21	27,7	27,7	38	18	92	1	3258951170991
E117250	22	29,8	29,8	40	18	118	1	3258951172506
E117251	23	30,8	30,8	40	18	125	1	3258951172513
E117252	24	31,8	31,8	40	18	134	1	3258951172520
E031937	25	32,8	32,8	41	20	142	1	3258950319377
E117253	26	33,8	33,8	41	20	160	1	3258951172537
E117254	27	35,8	35,8	41	20	192	1	3258951172544
E117255	28	37,6	37,6	41	20	220	1	3258951172551
E117256	29	37,8	37,8	41	20	210	1	3258951172568
E117257	30	39,8	39,8	41	20	234	1	3258951172575
E117258	32	41,8	41,8	41	20	266	1	3258951172582
E031936	34	43,8	43,8	45,50	25	300	1	3258950319360
E031938	36	49,8	49,8	57,20	27	462	1	3258950319384





DOUILLES 1/2"

DOUILLES 1/2" - 12 PANS - MÉTRIQUES

- ISO 2725-1 - DIN 3124 - ISO 1174-1 - ISO 1711-1 - ISO 691
- Acier au chrome vanadium.
- Profil Maxi Drive : transmission du couple de serrage sur les flancs de l'écrou et non sur les arêtes.
- Finition chrome brillant.
- Pour une utilisation manuelle.

	A mm	d1 mm	d2 mm	L mm	L1 mm	Poids g	☒	EAN
E117051	8	21.8	12.4	38	9	45	1	3258951170519
E117052	9	21.8	14	38	10	45	1	3258951170526
E117053	10	21.8	15.5	38	10	18	1	3258951170533
E117054	11	21.8	16.7	38	10	50	1	3258951170540
E117055	12	21.8	18	38	10	50	1	3258951170557
E117056	13	21.8	19.2	38	10	52	1	3258951170564
E117057	14	21.8	20.5	38	10	54	1	3258951170571
E117058	15	21.8	21	38	14	54	1	3258951170588
E117059	16	23.3	22.5	38	14	66	1	3258951170595
E117060	17	24	24	38	14	76	1	3258951170601
E117061	18	24.8	24.8	38	14	84	1	3258951170618
E117062	19	26.3	26.3	38	16.7	84	1	3258951170625
E117063	20	26.8	26.8	38	17.3	84	1	3258951170632
E117064	21	27.7	27.7	38	18	92	1	3258951170649
E117065	22	29.8	29.8	40	18	118	1	3258951170656
E117066	23	30.8	30.8	40	18	125	1	3258951170663
E117067	24	31.8	31.8	40	18	134	1	3258951170670
E117068	26	33.8	33.8	41	20	160	1	3258951170687
E117069	27	35.8	35.8	41	20	192	1	3258951170694
E117070	28	37.6	37.6	41	20	210	1	3258951170700
E117071	29	37.8	37.8	41	20	210	1	3258951170717
E117072	30	39.8	39.8	41	20	234	1	3258951170724
E117073	32	41.8	41.8	41	20	266	1	3258951170731
E032001	36	49.8	49.8	57,20	27	462	1	3258950320014

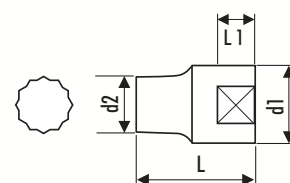

DOUILLES 1/2" - 12 PANS - POUCES

- ASME B 107-1 - ISO 1174-1
- Acier au chrome vanadium.
- Profil Maxi Drive : transmission du couple de serrage sur les flancs de l'écrou et non sur les arêtes.
- Finition chrome brillant.
- Pour une utilisation manuelle.

	A "	d1 mm	d2 mm	L mm	L1 mm	Poids g	☒	EAN
E113701	3/8"	21.8	14.7	38	9	45	1	3258951137017
E113702	7/16"	21.8	17	38	9	45	1	3258951137024
E113703	1/2"	21.8	19	38	10	48	1	3258951137031
E117074	9/16"	21.8	20.8	38	12.5	55	1	3258951170748
E117075	19/32"	21.8	20.8	38	14.3	55	1	3258951170755
E117076	5/8"	23.3	22.5	38	14.3	68	1	3258951170762
E113704	21/32"	23.3	23.3	38	14.3	68	1	3258951137048
E117077	11/16"	24.2	24.2	38	14.3	74	1	3258951170779
E117078	3/4"	26.3	26.3	38	18	87	1	3258951170786
E113705	25/32"	26.8	26.8	38	18	86	1	3258951137055
E117079	13/16"	27.7	27.7	38	18	92	1	3258951170793
E117080	7/8"	29.8	29.8	38	18	117	1	3258951170809
E117081	15/16"	31.8	31.8	38	18	136	1	3258951170816
E113706	31/32"	32.8	32.8	38	18	140	1	3258951137062
E117082	1"	33.8	33.8	41	18	148	1	3258951170823
E117083	1"1/16	35.8	35.8	41	20	190	1	3258951170830
E117084	1"1/8	37	37	41	20	228	1	3258951170847
E113707	1"3/16	39.8	39.8	41	20	230	1	3258951137079
E117085	1"1/4	41.8	41.8	41	20	268	1	3258951170854

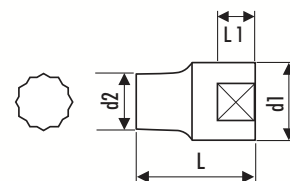



DOUILLES LONGUES 1/2" - 6 PANS - MÉTRIQUES

- ISO 2725-1 - DIN 3124 - ISO 1174-1 - ISO 1711-1 - ISO 691
- Acier au chrome vanadium.
- Profil Maxi Drive : transmission du couple de serrage sur les flancs de l'écrou et non sur les arêtes.
- Finition chrome brillant.
- Pour une utilisation manuelle.

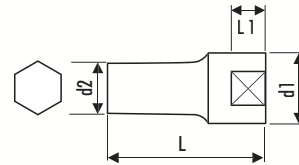

	A mm	d1 mm	d2 mm	L mm	L1 mm	Poids g	☒	EAN
E032103	10	22	15.5	79	17	98	1	3258950321035
E117265	12	22	18	79	19	105	1	3258951172650
E117266	13	22	19.2	79	21	115	1	3258951172667
E117267	14	22	20.5	79	25	120	1	3258951172674
E117268	15	22	21	79	28	125	1	3258951172681
E117269	16	23.3	22.5	79	31	128	1	3258951172698
E117270	17	24	24	79	34	140	1	3258951172704
E117271	18	25.3	25.3	79	34	160	1	3258951172711
E117272	19	26.5	26.5	79	36	160	1	3258951172728
E117273	21	27.8	27.8	79	36	200	1	3258951172735
E117274	22	29.8	29.8	79	36	215	1	3258951172742
E117275	24	31.8	31.8	79	36	255	1	3258951172759
E117276	27	35.8	35.8	79	36	310	1	3258951172766
E117277	30	39.8	39.8	79	36	355	1	3258951172773

DOUILLES LONGUES 1/2" - 12 PANS - MÉTRIQUES

- ISO 2725-1 - DIN 3124 - ISO 1174-1 - ISO 1711-1 - ISO 691
- Acier au chrome vanadium.
- Profil Maxi Drive : transmission du couple de serrage sur les flancs de l'écrou et non sur les arêtes.
- Finition chrome brillant.
- Pour une utilisation manuelle.

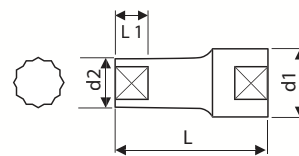

	A mm	d1 mm	d2 mm	L mm	L1 mm	Poids g	☒	EAN
E032203	10	22	15.5	79	17	98	1	3258950322032
E117278	12	22	18	79	19	105	1	3258951172780
E117279	13	22	19.2	79	21	115	1	3258951172797
E117280	14	22	20.5	79	25	120	1	3258951172803
E117281	15	22	21	79	28	125	1	3258951172810
E117282	16	23.3	22.5	79	31	128	1	3258951172827
E117283	17	24	24	79	34	140	1	3258951172834
E117284	18	25.3	25.3	79	34	160	1	3258951172841
E117285	19	26.5	26.5	79	36	160	1	3258951172858
E117286	21	27.8	27.8	79	36	200	1	3258951172865
E117287	22	29.8	29.8	79	36	215	1	3258951172872
E117288	23	30.8	30.8	79	36	232	1	3258951172889
E117289	24	31.8	31.8	79	36	255	1	3258951172896
E117290	27	35.8	35.8	79	36	310	1	3258951172902
E117291	30	39.8	39.8	79	36	355	1	3258951172919
E117292	32	41.3	41.3	79	36	408	1	3258951172926





DOUILLES 1/2"

DOUILLES LONGUES 1/2" - 12 PANS - POUCES

- ASME B 107-1 - ISO 1174-1
- Acier au chrome vanadium.
- Profil Maxi Drive : transmission du couple de serrage sur les flancs de l'écrou et non sur les arêtes.
- Finition chrome brillant.
- Pour une utilisation manuelle.

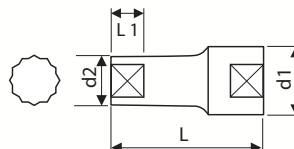

	A"	d1 mm	d2 mm	L mm	L1 mm	Poids g	☒	EAN
E113713	1/2"	22	19	79	20	116	1	3258951137130
E113714	9/16"	22	20.8	79	22	118	1	3258951137147
E113715	5/8"	23.3	22.5	79	24	126	1	3258951137154
E113716	11/16"	24	24	79	26	146	1	3258951137161
E113717	3/4"	26	26	79	29	180	1	3258951137178
E113718	13/16"	27	27	79	31	240	1	3258951137185
E113719	1/8"	29	29	79	31	250	1	3258951137192
E113720	15/16"	31	31	79	33	265	1	3258951137208
E113721	1"	33	33	79	33	290	1	3258951137215
E113722	1 1/16	35	35	79	33	315	1	3258951137222
E113723	1 1/8	37	37	79	33	350	1	3258951137239
E113724	1 1/4	41	41	79	33	360	1	3258951137246

DOUILLES TORX® 1/2"

DOUILLES TORX® 1/2"

- ISO 1174-1
- Pour vis mâles Torx®.
- Acier au chrome vanadium.
- Finition : chrome brillant.

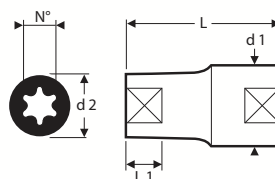

	N°	d1 mm	d2 mm	L mm	L1 mm	Poids g	☒	EAN
E031984	E8	21,8	11	38	12,7	49	1	3258950319841
E031927	E10	21,8	13,3	38	10	41	1	3258950319278
E031935	E11	21,8	14	38	11	41	1	3258950319353
E031928	E12	21,8	15	38	12	47	1	3258950319285
E031929	E14	21,8	17	38	12	47	1	3258950319292
E031930	E16	21,8	18,5	38	12	57	1	3258950319308
E031931	E18	21,8	20	38	12	57	1	3258950319315
E031932	E20	23,3	23,3	38	13	63	1	3258950319322
E031933	E22	24,8	24,8	38	15	80	1	3258950319339
E031934	E24	26,8	26,8	38	16	97	1	3258950319346



DOUILLES TOURNEVIS 1/2"

DOUILLES TOURNEVIS 1/2" POUR VIS 6 PANS CREUX

- ISO 2725-1 - DIN3124 - ISO 1174-1
- Acier au chrome vanadium.
- Finition : chrome brillant.

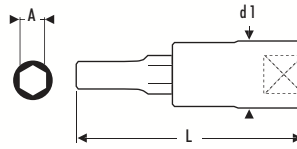

	A mm	d1 mm	L mm	Poids g	☒	EAN
E031901	4	22	55	59	1	3258950319018
E031902	5	22	55	60	1	3258950319025
E031903	6	22	55	62	1	3258950319032
E031904	7	22	55	64	1	3258950319049
E031905	8	22	55	65	1	3258950319056
E031906	9	22	55	72	1	3258950319063
E031907	10	22	55	80	1	3258950319070
E031908	12	22	55	102	1	3258950319087
E031909	14	22	55	127	1	3258950319094
E031910	17	22	55	152	1	3258950319100
E031911	19	22	55	201	1	3258950319117

DOUILLES TOURNEVIS 1/2" EMBOUT LONG POUR VIS 6 PANS CREUX

- ISO 2725-1 - DIN3124 - ISO 1174-1
- Acier au chrome vanadium.
- Finition : chrome brillant.

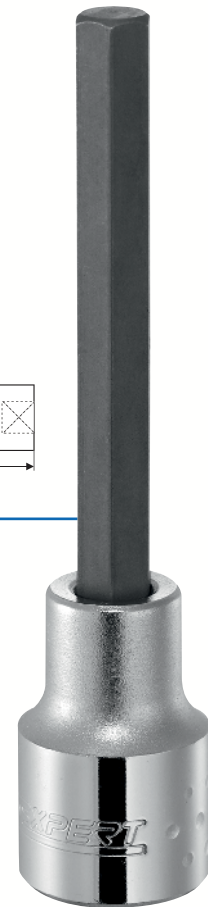
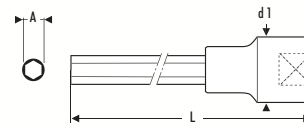

	A mm	d1 mm	L mm	Poids g	☒	EAN
E031912	4	22	100	69	1	3258950319124
E031913	5	22	100	71	1	3258950319131
E031914	6	22	100	77	1	3258950319148
E031982	7	22	100	75	1	3258950319827
E031915	8	22	100	79	1	3258950319155
E031916	10	22	100	132	1	3258950319162
E031917	12	22	100	144	1	3258950319179
E031983	14	22	100	153	1	3258950319834

DOUILLES TOURNEVIS 1/2" POUR VIS TORX®

- ISO 1174-1
- Acier au chrome vanadium.
- Finition : chrome brillant.

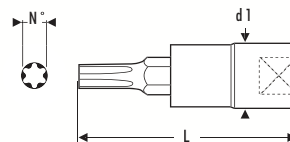

	N°	d1 mm	L mm	Poids g	☒	EAN
E031918	T20	22	55	58	1	3258950319186
E031919	T25	22	55	58	1	3258950319193
E031920	T27	22	55	59	1	3258950319209
E031921	T30	22	55	59	1	3258950319216
E031922	T40	22	55	62	1	3258950319223
E031923	T45	22	55	63	1	3258950319230
E031924	T50	22	55	74	1	3258950319247
E031925	T55	22	55	96	1	3258950319254
E031926	T60	22	55	117	1	3258950319261

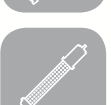



DOUILLES TOURNEVIS 1/2"

DOUILLES TOURNEVIS 1/2" EMBOUT LONG POUR VIS TORX®

- ISO 1174 - ISO3120
- Acier au chrome vanadium.
- Finition: chrome brillant.

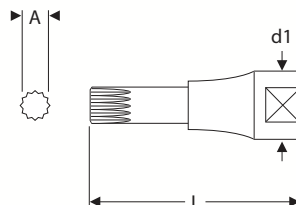

	A mm	d1 mm	L mm	Poids g	☒	EAN
E031978	T40	22	120	93	1	3258950319780
E031980	T45	22	120	94	1	3258950319797
E031981	T50	22	120	102	1	3258950319803
E031979	T55	22	120	127	1	3258950319810



DOUILLES TOURNEVIS 1/2" POUR VIS XZN®

- ISO 1174 - ISO3120
- Acier au chrome vanadium.
- Finition: chrome brillant.

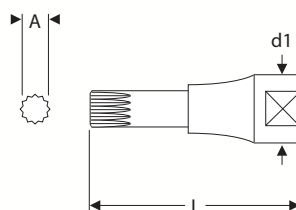

	A mm	d1 mm	L mm	Poids g	☒	EAN
E031967	M5	22	55	52	1	3258950319674
E031968	M6	22	55	56	1	3258950319681
E031969	M8	22	55	59	1	3258950319698
E031970	M10	22	55	70	1	3258950319704
E031971	M12	22	55	77	1	3258950319711
E031972	M14	22	55	91	1	3258950319728
E031973	M16	22	55	98	1	3258950319735



DOUILLES TOURNEVIS 1/2" EMBOUT LONG POUR VIS XZN®

- ISO 1174 - ISO3120
- Acier au chrome vanadium.
- Finition: chrome brillant.

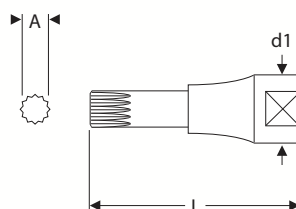

	A mm	d1 mm	L mm	Poids g	☒	EAN
E031974	M8	24	120	126	1	3258950319742
E031975	M10	24	120	128	1	3258950319759
E031976	M12	24	120	159	1	3258950319766
E031977	M14	24	120	191	1	3258950319773





COMPOSITIONS DE DOUILLES 3/4"

COFFRET DE DOUILLES 3/4" - 14 PIÈCES

- Douilles 3/4" 6 pans : 22-24-27-30-32-34-36-41-46-50 mm.
- 1 poignée coulissante 3/4"
- 1 cliquet 3/4".
- 2 rallonges 3/4" : 200-400 mm.
- Livré en boîte métallique.



E194682	3/4"	Quantité	Dimensions	Poids kg	☒	EAN
E194682	3/4"	14	L.539xP.133xH.80 mm	14	1	3258951946824

COFFRET DE DOUILLES 3/4" - 18 PIÈCES

- Douilles 3/4" 6 pans : 19-21-22-24-27-30-32-34-36-41-46-50-55 mm.
- 2 rallonges 3/4" : 200-400 mm.
- 1 poignée coulissante 3/4".
- 1 cliquet 3/4".
- 1 cardan 3/4".
- Livré en boîte métallique.



E194683	3/4"	Quantité	Dimensions	Poids kg	☒	EAN
E194683	3/4"	18	L.539xP.133xH.80 mm	15,5	1	3258951946831

CLIQUETS 3/4"

CLIQUET AVEC MANCHE 3/4"

- ISO 3315 - DIN 3122 - ISO 1174-1
- Equipé d'un verrouillage de sécurité pour douilles et accessoires.
- Mécanisme 24 dents.
- Angle de reprise 15°.
- Acier chrome vanadium.
- Finition : chrome mat.
- Livré avec manche verrouillable sur la tête de cliquet.

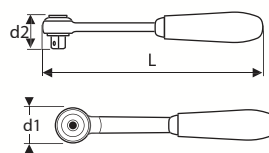
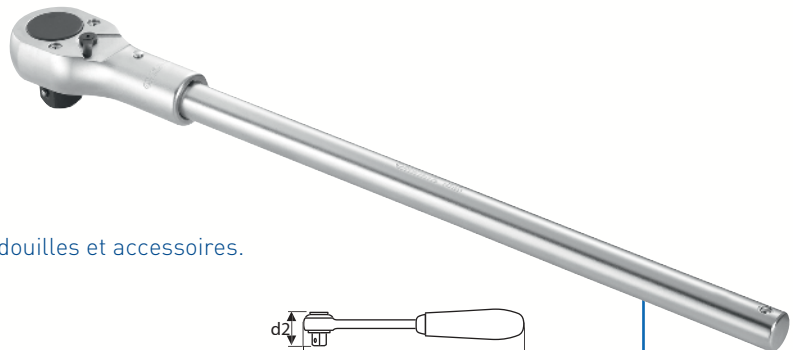

E113819	d1 mm	d2 mm	L mm	Poids kg	☒	EAN
E113819	63,4	59	568	2,37	1	3258951138199





CLIQUETS 3/4"

CLIQUET 3/4"

- ISO 3315 - DIN 3122 - ISO 1174-1
- Equipé d'un verrouillage de sécurité pour douilles et accessoires.
- Mécanisme 24 dents.
- Angle de reprise 15°.
- Finition : chrome mat.
- Acier chrome vanadium.
- Livré sans manche.

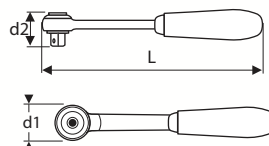

E113817	d1 mm	d2 mm	L mm	Poids kg		EAN
E113817	63.4	59	155	1,24	1	3258951138175

MANCHE POUR CLIQUET 3/4"

- ISO 3315 - DIN 3122
- Finition : chrome mat.
- Pour une utilisation manuelle.
- Acier chrome vanadium.

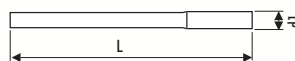
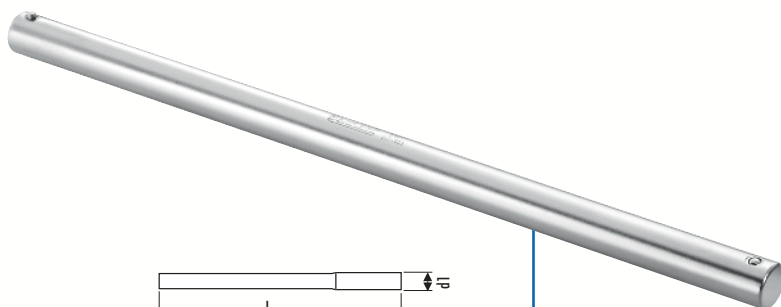

E113816	d1 mm	L mm	Poids kg		EAN
E113816	20	455	1,13	1	3258951138168

ACCESSOIRES 3/4"

POIGNÉE COULISSANTE 3/4"

- ISO 3315 - DIN 3122 - ISO 1174-1
- Haute résistance au couple.
- Acier au chrome vanadium.
- Finition : chrome mat.
- Pour une utilisation manuelle.
- Equipé d'un verrouillage de sécurité avec douilles et accessoires.

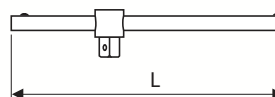
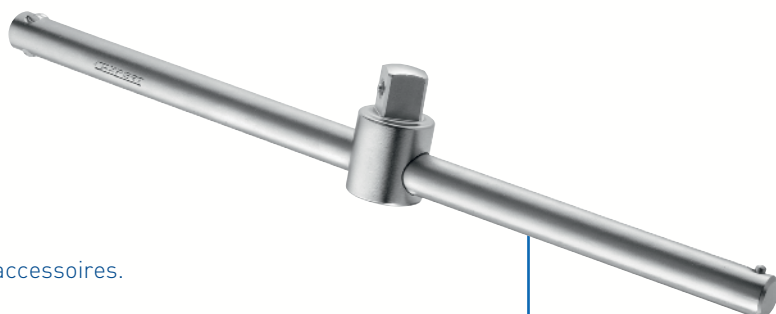

E113815	L mm	Poids kg		EAN
E113815	455	1,30	1	3258951138151



POIGNÉE ARTICULÉE 3/4"

- ISO 3315 - DIN 3122 - ISO 1174-1
- Haute résistance au couple.
- Acier au chrome vanadium.
- Finition : chrome mat.
- Pour une utilisation manuelle.



	L mm	Poids kg	📦	EAN
E033804	1250	3,70	1	3258950338040

RALLONGES 3/4"

- ISO 3316 - DIN 3123 - ISO 1174-1
- Finition : chrome mat.
- Acier chrome vanadium.
- Pour une utilisation manuelle.

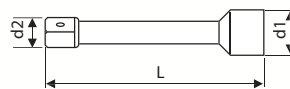
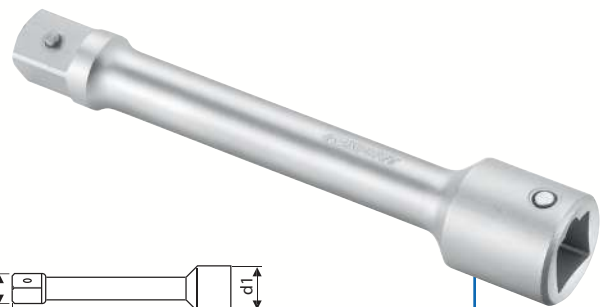

	d1 mm	d2 mm	L mm	Poids g	📦	EAN
E113820	35.5	25	100	410	1	3258951138205
E113823	35.5	25	400	1130	1	3258951138236
E113824	35.5	25	200	620	1	3258951138243

RÉDUCTEUR 3/4" - 1/2"

- ISO 3316 - DIN 3123 - ISO 1174-1
- Verrouillage de sécurité.
- Acier chrome vanadium.
- Pour une utilisation manuelle.

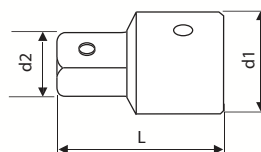

	d1 mm	d2 mm	L mm	Poids g	📦	EAN
E113821	34	12.58	48	166	1	3258951138212





ACCESSOIRES 3/4"

AUGMENTATEUR 3/4" - 1"

- ISO 3316 - DIN 3123 - ISO 1174-1
- Finition : chrome mat.
- Verrouillage de sécurité.
- Acier chrome vanadium.
- Pour une utilisation manuelle.

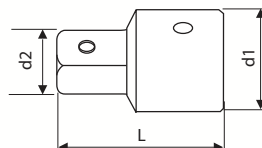

E033802	d1 mm	d2 mm	L mm	Poids g		EAN
E033802	38	33.5	62	340	1	3258950338026

CARDAN 3/4"

- ISO 3316 - DIN 3123 - ISO 1174-1
- Finition : chrome mat.
- Verrouillage de sécurité.
- Acier chrome vanadium.
- Pour une utilisation manuelle.

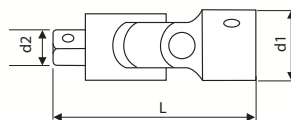

E113822	d1 mm	d2 mm	L mm	Poids g		EAN
E113822	40	25	107	550	1	3258951138229

CARDAN 3/4" POUR BARRE

- ISO 3316 - DIN 3123 - ISO 1174-1
- Acier chrome vanadium.
- Finition : chrome mat.
- Utilisation avec manche E113816.
- Verrouillage de sécurité.
- Pour une utilisation manuelle.

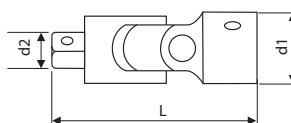

E033801	d1 mm	d2 mm	L mm	Poids g		EAN
E033801	36	25	138	550	1	3258950338019



DOUILLES 3/4"

DOUILLES 3/4" - 6 PANS - MÉTRIQUES

- ISO 2725-1 - DIN 3124 - ISO 1174-1 - ISO 1711-1 - ISO 691
- Verrouillage de sécurité.
- Acier chrome vanadium.
- Finition : chrome mat.
- Pour une utilisation manuelle.

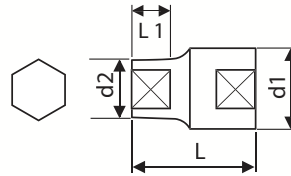

	A mm	d1 mm	d2 mm	L mm	L1 mm	Poids g	☒	EAN
E113790	19	33	27.2	50	14	207	1	3258951137901
E113791	21	33	31.2	50	16.5	208	1	3258951137918
E113792	22	36	32.2	50	16.5	221	1	3258951137925
E113793	23	36	33.2	50	16.5	244	1	3258951137932
E113794	24	36	34.2	51	16.5	237	1	3258951137949
E113795	26	36	37	52	22	231	1	3258951137956
E113796	27	36	38	52	22	232	1	3258951137963
E113797	28	36	39.5	52	22	239	1	3258951137970
E113798	29	36	40.5	52	24	245	1	3258951137987
E113799	30	36	42	54	24	282	1	3258951137994
E113800	32	36	44	56	24	301	1	3258951138007
E113801	33	36	46	56	26	330	1	3258951138014
E113802	34	36	47	56	26	322	1	3258951138021
E113803	35	38	48	58	26	344	1	3258951138038
E113804	36	38	50	58	28	347	1	3258951138045
E113805	38	38	52	60	28	478	1	3258951138052
E113806	40	40	54	62	30	493	1	3258951138069
E113807	41	40	56	64	30	504	1	3258951138076
E113808	42	40	57	64	30	552	1	3258951138083
E113809	44	40	60	66	32	587	1	3258951138090
E113810	46	42	62	66	32	641	1	3258951138106
E113811	50	42	68	70	34	725	1	3258951138113
E113812	54	45	72	72	36	880	1	3258951138120
E113813	55	45	75	75	36	875	1	3258951138137



DOUILLES 3/4" - 12 PANS - POUCES

- ASME B 107-1 - ISO 1174-1
- Verrouillage de sécurité.
- Acier chrome vanadium.
- Finition : chrome mat.
- Pour une utilisation manuelle.

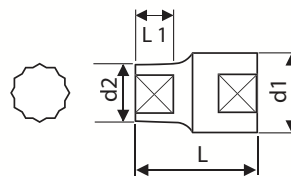

	A"	d1 mm	d2 mm	L mm	L1 mm	Poids g	☒	EAN
E033503	7/8"	33	31.2	50	14	210	1	3258950335032
E033504	15/16"	36.2	34.2	51	16.5	220	1	3258950335049
E033505	1"	36	37	52	16.5	220	1	3258950335056
E033506	1"1/16	36	38	52	22	220	1	3258950335063
E033507	1"1/8	36	40	52	22	250	1	3258950335070
E033508	1"3/16	36	42	54	24	260	1	3258950335087
E033509	1"1/4	36	44	56	24	270	1	3258950335094
E033510	1"5/16	36	46	56	26	300	1	3258950335100
E033511	1"3/8	38	48	58	26	340	1	3258950335117
E033512	1"7/16	38	50	58	28	350	1	3258950335124
E033513	1"1/2	38	52	60	28	390	1	3258950335131
E033514	1"5/8	40	56	64	30	480	1	3258950335148
E033515	1"7/8	42	64	68	34	660	1	3258950335155
E033516	1"3/4	40	60	66	32	560	1	3258950335162
E033517	1"13/16	42	62	66	32	620	1	3258950335179
E033518	2"	42	68	70	34	680	1	3258950335186





COMPOSITION DE DOUILLES 1"

COFFRET CLIQUET DOUILLES 1" - 14 PIÈCES

- Douilles 1" 6 pans : 41-46-50-55-60-65-70-75-80 mm.
- 2 rallonges 1" : 200-400 mm.
- 1 cliquet 1" avec manche.
- 1 poignée coulissante 1".
- Livré en boîte métallique : E034702.



E034701	1"	Quantité	Dimensions	Poids kg	☒	EAN
		14	L.658xP.211xH.108 mm	29	1	3258950347011

CLIQUET 1"

CLIQUET 1"

- ISO 3315 - DIN 3122 - ISO 1174-1
- Verrouillage de sécurité pour douilles et accessoires.
- Bouton de déverrouillage rapide.
- Acier chrome vanadium.
- Finition : chrome mat.
- Livré avec manche verrouillable sur la tête de cliquet.

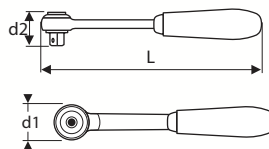
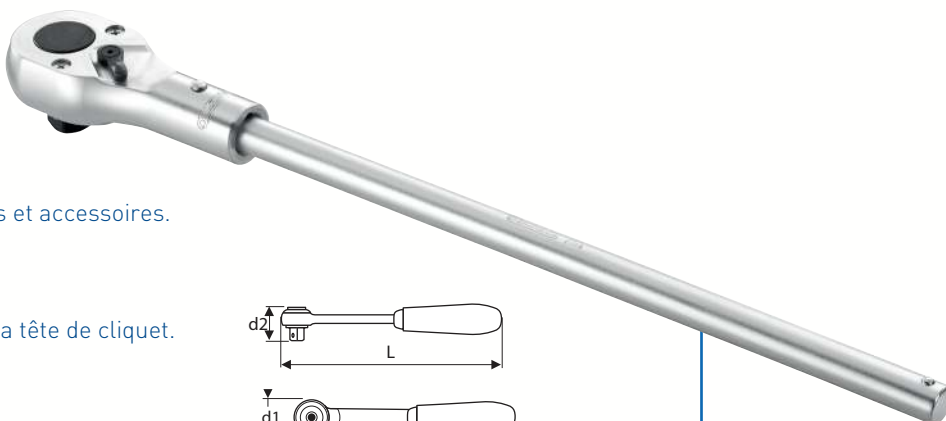

E034601	d1 mm	d2 mm	L mm	Poids kg	☒	EAN
	71.5	71	666	2	1	3258950346014

ACCESSOIRES 1"

POIGNÉE COULISSANTE 1"

- ISO 3316 - DIN 3123 - ISO 1174-1
- Verrouillage de sécurité.
- Bouton de déverrouillage rapide.
- Acier chrome vanadium.
- Finition : chrome mat.

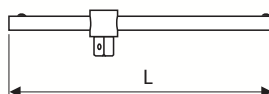

E034503	L mm	Poids kg	☒	EAN
	500	2,4	1	3258950345031



RALLONGES 1"

- ISO 3316 - DIN 3123 - ISO 1174-1
- Verrouillage de sécurité.
- Bouton de déverrouillage rapide.
- Finition : chrome mat.
- Acier chrome vanadium.

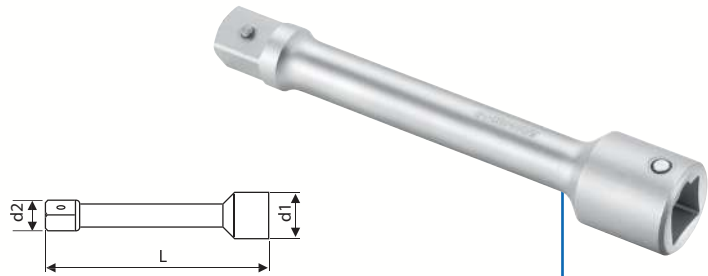

	d1 mm	d2 mm	L mm	Poids kg	☒	EAN
E034501	48	33.5	200	1,1	1	3258950345017
E034502	48	33.5	400	2	1	3258950345024

RÉDUCTEUR 1" - 3/4"

- ISO 3316 - DIN 3123 - ISO 1174-1
- Acier chrome vanadium.
- Finition : chrome mat.
- Verrouillage de sécurité.
- Pour une utilisation manuelle.

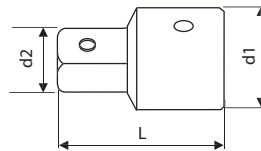

	d1 mm	d2 mm	L mm	Poids g	☒	EAN
E033803	42	33.5	80	415	1	3258950338033

DOUILLES 1"

DOUILLES 1" - 6 PANS - MÉTRIQUES

- ISO 2725-1 - DIN 3124 - ISO 1174-1 - ISO 1711-1 ISO 691
- Verrouillage de sécurité.
- Bouton de déverrouillage rapide.
- Finition : chrome mat.
- Acier chrome vanadium.
- Pour une utilisation manuelle.

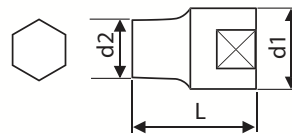

	A mm	d1 mm	d2 mm	L mm	Poids g	☒	EAN
E034101	41	47	45	70	685	1	3258950341019
E034102	46	65	50	75	852	1	3258950341026
E034103	50	70	50	75	968	1	3258950341033
E034104	55	76	55	80	1262	1	3258950341040
E034105	60	82	55	84	1432	1	3258950341057
E034106	65	88	55	87	1652	1	3258950341064
E034107	70	94	60	70	1921	1	3258950341071
E034108	75	100	60	97	2261	1	3258950341088
E034109	80	105	60	103	2800	1	3258950341095



VISSAGE





Tournevis

P.104



Tournevis bi-matière

P.112



Clés à douilles emmanchées

P.116



Jeu de clés mâles

P.117



Clés mâles 6 pans

P.118



Clés mâles en T

P.123



Tournevis à frapper

P.127



Coffrets d'embouts

P.128



Embouts de vissage

P.130



Porte-embouts et accessoires

P.132



PINCES 1000 VOLTS ET TOURNEVIS DE PRÉCISION

Voir section Électricité - Électronique p 218.





JEUX DE TOURNEVIS

JEU DE 10 TOURNEVIS FENTE-PHILLIPS®

- Tournevis pour vis à fente (mécanicien) : 2,5 x 75 - 3 x 75 - 4 x 100 - 5,5 x 125 - 6,5 x 150 (écrou) mm.
- Tournevis pour vis à fente (compact) : 4 x 30 mm.
- Tournevis Phillips® : PH0 x 75 - PH1 x 100 - PH2 x 125.
- Tournevis Phillips® (compact) : PH2 x 30.



	Quantité	Poids g		EAN
E160905	10	740	5	3258951609057

JEU DE 8 TOURNEVIS FENTE-PHILLIPS®

- Tournevis pour vis à fente (électricien) : 3 x 50 - 4 x 100 mm.
- Tournevis pour vis à fente (mécanicien) : 5,5 x 125 - 6,5 x 150 - 8 x 175 (écrou) mm.
- Tournevis Phillips® : PH0 x 75 - PH1 x 100 - PH2 x 125 (écrou).



	Quantité	Poids g		EAN
E160904	8	800	5	3258951609040

JEU DE 8 TOURNEVIS FENTE-POZIDRIV®

- Tournevis pour vis à fente (électricien) : 3 x 50 - 4 x 100 mm.
- Tournevis pour vis à fente (mécanicien) : 5,5 x 125 - 6,5 x 150 - 8 x 175 (écrou) mm.
- Tournevis Pozidriv® : PZ0 x 75 - PZ1 x 100 - PZ2 x 125 (écrou).

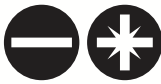

	Quantité	Poids g		EAN
E160906	8	800	5	3258951609064



JEU DE 8 TOURNEVIS FENTE-PHILLIPS®-POZIDRIV®

- Tournevis pour vis à fente (électricien) : 3 x 50 - 4 x 100 mm.
- Tournevis pour vis à fente (mécanicien) : 5,5 x 125 - 6,5 x 150 mm.
- Tournevis Pozidriv® : PZ1 x 100 - PZ2 x 125.
- Tournevis Phillips® : PH1 X 100 - PH2 x 125.



	Quantité	Poids g	📦	EAN
E160907	8	710	5	3258951609071



JEU DE 6 TOURNEVIS FENTE-PHILLIPS®

- Tournevis pour vis à fente (mécanicien) : 2,5 x 75 - 3 x 75 - 4 x 100 - 5,5 x 125 mm.
- Tournevis Phillips® : PH1 x 100 - PH2 x 125.



	Quantité	Poids g	📦	EAN
E160902	6	430	5	3258951609026



JEU DE 6 TOURNEVIS FENTE-POZIDRIV®

- Tournevis pour vis à fente (électricien) : 3,5 x 75 - 5,5 x 125 mm.
- Tournevis pour vis à fente (mécanicien) : 6,5 x 150 - 8 x 175.
- Tournevis Pozidriv® : PZ1 x 100 - PZ2 x 125.

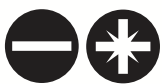

	Quantité	Poids g	📦	EAN
E160903	6	720	5	3258951609033





JEUX DE TOURNEVIS

JEU DE 5 TOURNEVIS FENTE-PHILLIPS®

- Tournevis pour vis à fente (électricien) : 3,5 x 75 - 4 x 100 - 5,5 x 125 mm.
- Tournevis Phillips® : PH1 x 100 - PH2 x 125.



E160901	Quantité	Poids g		EAN
E160901	5	330	5	3258951609019

MODULE DE 8 TOURNEVIS FENTE-PHILLIPS®

- Tournevis pour vis à fente (électricien) : 3,5 x 75 - 4 x 100.
- Tournevis pour vis à fente (mécanicien) : 5,5 x 125 - 6,5 x 150 - 8 x 175.
- Tournevis Phillips® : PH0 x 75 - PH1 x 100 - PH2 x 125.
- Plateau vide : E160916.



E194940	Quantité	L mm	L mm	Poids g		EAN
E194940	8	354	173	914	1	3258951949405



LES JEUX DE TOURNEVIS SONT LIVRÉS DANS DES BOÎTES PROMOTIONNELLES ANTI-VOL ET PAR MULTIPLE DE 5 JEUX FOURNIS DANS UN PRÉSENTOIR DE COMPTOIR.





JEU DE 7 TOURNEVIS TORX®

→ ACUMENT TMD 702

→ Tournevis Torx® : T10-T15-T20-T25-T27-T30-T40.



E160908	Quantité	Poids g	📦	EAN
E160908	7	640	5	3258951609088



JEU DE 7 TOURNEVIS RÉSORTORX®

→ ACUMENT CID 602

→ Tournevis Resistorx® :

TT10-TT15-TT20-TT25-TT27-TT30-TT40.



E160909	Quantité	Poids g	📦	EAN
E160909	7	640	5	3258951609095



MODULE DE 6 TOURNEVIS RÉSORTORX®

→ Tournevis Resistorx® : TT10-TT15-TT20-TT25-TT30-TT40.

→ Plateau vide : E160917.



E194941	Quantité	L mm	L mm	Poids g	📦	EAN
E194941	6	354	173	744	1	3258951949412





TOURNEVIS

TOURNEVIS POUR VIS FENTE ÉLECTRICIEN

- ISO 2380-1 - ISO 2380-2
- Manche ergonomique tri-matière confortable et efficace.
- Code couleur empreinte : rouge.
- Lame en acier au Chrome Vanadium ronde fraisée, chromée.
- Extrémité sablée.



	A x L2 x B mm	L1 mm	d mm	Poids g		EAN
E160101	2,0 x 50 x 0,4	149	20	16	5	3258951601013
E165006	2,5 x 50 x 0,4	149	20	18	5	3258951650066
E164978	3,0 x 50 x 0,5	149	20	20	5	3258951649787
E164983	3,5 x 75 x 0,6	177	27	37	5	3258951649831
E165017	4,0 x 100 x 0,8	202	27	43	5	3258951650172
E165093	4,0 x 150 x 0,8	252	27	50	5	3258951650936
E160102	4,0 x 250 x 0,8	352	27	65	5	3258951601020
E165476	5,5 x 125 x 1,0	230	32	80	5	3258951654767
E160103	5,5 x 250 x 1,0	355	32	104	5	3258951601037
E165096	6,5 x 150 x 1,2	266	40	133	5	3258951650967
E160104	6,5 x 250 x 1,2	366	40	164	5	3258951601044

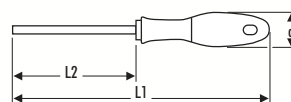

TOURNEVIS POUR VIS FENTE MÉCANICIEN

- ISO 2380-1 - ISO 2380-2
- Manche ergonomique tri-matière confortable et efficace.
- Code couleur empreinte : rouge.
- Lame en acier au Chrome Vanadium ronde forgée, chromée.
- Extrémité sablée.

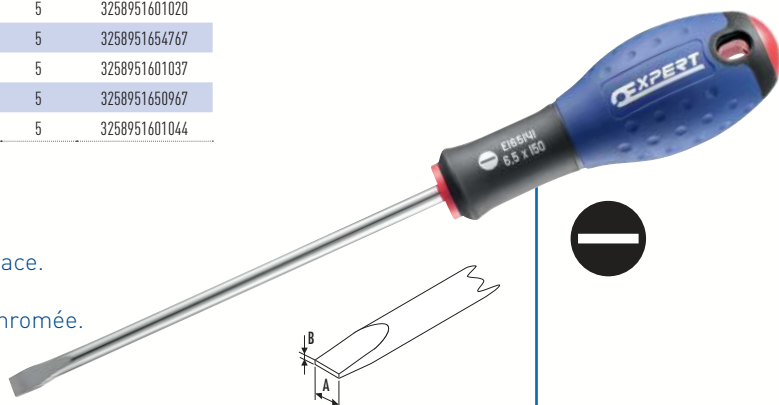

	A x L2 x B mm	L1 mm	d mm	Poids g		EAN
E160201	2,5 x 75 x 0,4	177	27	28	10	3258951602010
E165479	3 x 75 x 0,5	173	30	31	10	3258951654798
E165480	3 x 100 x 0,5	198	38	32	10	3258951654804
E165016	4 x 100 x 0,8	202	43	42	10	3258951650165
E165481	4 x 125 x 0,8	227	47	46	10	3258951654811
E165483	5,5 x 150 x 1,0	227	32	47	10	3258951654835
E165098	5,5 x 100 x 1,0	205	32	69	10	3258951650981
E165482	5,5 x 125 x 1,0	230	32	73	10	3258951654828
E160206	6,5 x 125 x 1,2	241	40	117	10	3258951602065
E165141	6,5 x 150 x 1,2	266	40	123	10	3258951651414
E165138	8,0 x 175 x 1,6	291	40	177	10	3258951651384

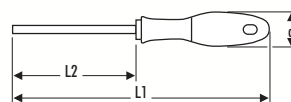

TOURNEVIS POUR VIS FENTE MÉCANICIEN AVEC ÉCROU

- ISO 2380-1 - ISO 2380-2
- Manche ergonomique tri-matière confortable et efficace.
- Code couleur empreinte : rouge.
- Lame en acier au Chrome Vanadium ronde forgée, chromée.
- Extrémité sablée.
- Écrou 6 pans.

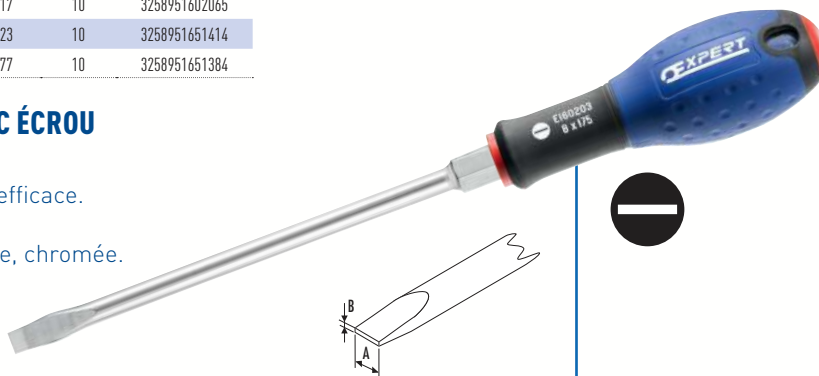

	A x L2 x B mm	L1 mm	d mm	Poids g		EAN
E160202	6,5 x 150 x 1,2	266	40	130	5	3258951602027
E160203	8,0 x 175 x 1,2	266	40	150	5	3258951602034
E160204	10 x 200 x 1,6	226	40	226	5	3258951602041
E160205	12 x 250 x 2,0	366	40	289	5	3258951602058

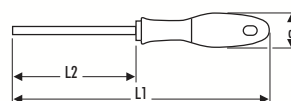



TOURNEVIS BOULE POUR VIS À FENTE ÉLECTRICIEN

→ ISO 2380-1 - ISO 2380-2

- Manche ergonomique tri-matière confortable et efficace.
- Code couleur empreinte : rouge.
- Lame en acier au chrome vanadium ronde fraisée, chromée.
- Extrémité sablée.
- Tournevis compact idéal pour les vis difficiles d'accès.

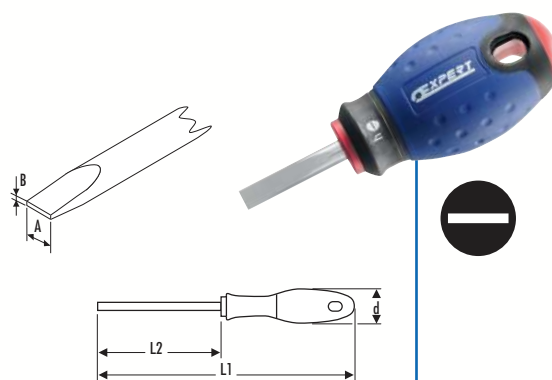

	A x L2 x B mm	L1 mm	d mm	Poids g	📦	EAN
E165484	4,0 x 25 x 0,8	86	32	33	5	3258951654842
E165400	5,5 x 25 x 1,0	86	32	39	5	3258951654002
E165404	6,5 x 25 x 1,2	86	32	45	5	3258951654040

TOURNEVIS TORX®

→ ACUMENT TMD 702

- Manche ergonomique tri-matière confortable et efficace.
- Code couleur empreinte : vert.
- Lame en acier au chrome vanadium ronde, chrome satiné.

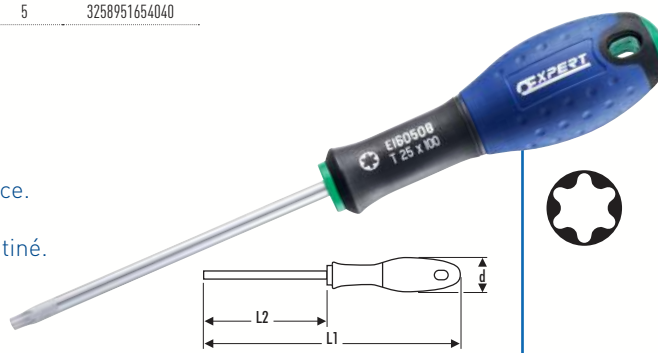

	N°	L1 mm	L2 mm	d mm	Poids g	📦	EAN
E160501	T6	148	50	20	18	5	3258951605011
E160502	T7	148	50	20	18	5	3258951605028
E160503	T8	148	50	20	18	5	3258951605035
E160504	T9	173	75	20	19	5	3258951605042
E160505	T10	177	75	27	34	5	3258951605059
E160506	T15	177	75	27	37	5	3258951605066
E160507	T20	202	100	27	44	5	3258951605073
E160508	T25	205	100	32	71	5	3258951605080
E160509	T27	205	100	32	75	5	3258951605097
E160510	T30	241	125	40	118	5	3258951605103
E160511	T40	241	125	40	135	5	3258951605110

TOURNEVIS RESISTORX®

→ ACUMENT CID 602

- Manche ergonomique tri-matière confortable et efficace.
- Code couleur empreinte : vert.
- Lame en acier au chrome vanadium ronde chromée.
- Extrémité sablée.

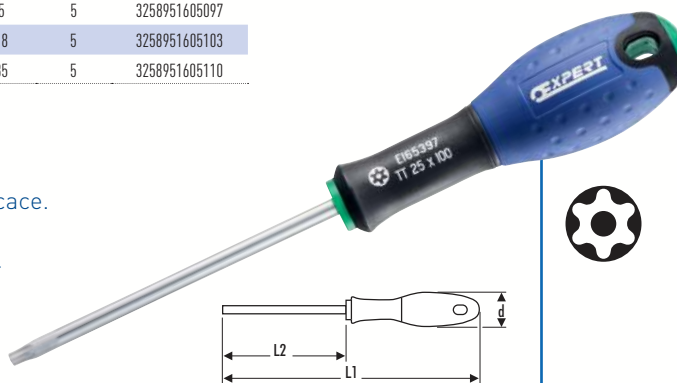

	N°	L1 mm	L2 mm	d mm	Poids g	📦	EAN
E165340	TT 10	177	75	27	34	5	3258951653401
E165395	TT 15	177	75	27	37	5	3258951653951
E165396	TT 20	202	100	27	44	5	3258951653968
E165397	TT 25	205	100	32	71	5	3258951653975
E160601	TT 27	205	100	32	75	5	3258951606018
E165398	TT 30	241	125	40	118	5	3258951653982
E165399	TT 40	241	125	40	135	5	3258951653999





TOURNEVIS

TOURNEVIS POUR VIS PHILLIPS®

→ ISO 8764-1 - ISO 8764-2

- Manche ergonomique tri-matière confortable et efficace.
- Code couleur empreinte : jaune.
- Lame en acier au chrome vanadium ronde chromée.
- Extrémité sablée.

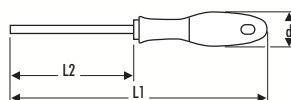
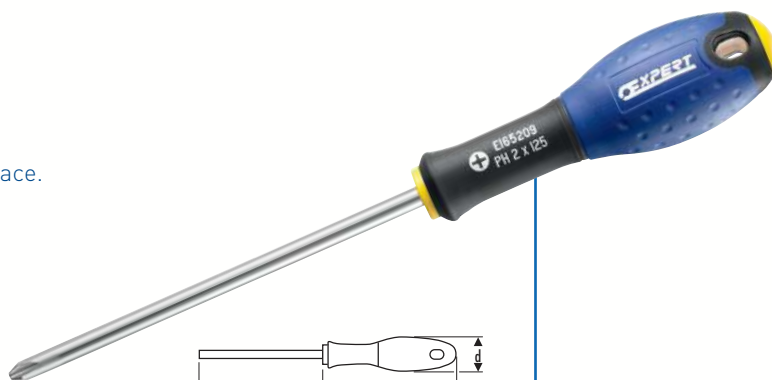

	N°	L1 mm	L2 mm	d mm	Poids g		EAN	
	E165204	PH 00	149	50	20	20	5	3258951652046
	E165206	PH 0	177	75	27	44	10	3258951652060
	E165207	PH 1	205	100	32	69	10	3258951652077
	E165209	PH 2	230	125	32	88	10	3258951652091
	E160304	PH 1	355	250	32	101	5	3258951603048
	E160305	PH 2	355	250	32	123	5	3258951603055

TOURNEVIS POUR VIS PHILLIPS® AVEC ÉCROU

→ ISO 8764-1 - ISO 8764-2

- Manche ergonomique tri-matière confortable et efficace.
- Code couleur empreinte : jaune.
- Lame en acier au chrome vanadium ronde chromée.
- Extrémité sablée.
- Écrou 6 pans.

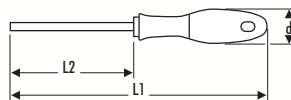

	N°	L1 mm	L2 mm	d mm	Poids g		EAN	
	E160301	PH 2	230	125	32	95	5	3258951603017
	E160302	PH 3	266	150	40	167	5	3258951603024
	E160303	PH 4	316	200	40	254	5	3258951603031

TOURNEVIS BOULE POUR VIS PHILLIPS®

→ ISO 8764-1- ISO 8764-2

- Manche ergonomique tri-matière confortable et efficace.
- Code couleur empreinte : jaune.
- Lame en acier au Chrome Vanadium ronde fraisée, chromée.
- Extrémité sablée.
- Tournevis compact idéal pour les vis difficiles d'accès.

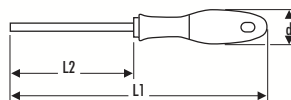

	N°	L1 mm	L2 mm	d mm	Poids g		EAN	
	E165406	PH 1	86	30	32	37	5	3258951654064
	E165407	PH 2	86	30	32	42	5	3258951654071



TOURNEVIS POUR VIS POZIDRIV®

- ISO 8764-1 - ISO 8764-2
- Manche ergonomique tri-matière confortable et efficace.
- Code couleur empreinte : bleu.
- Lame en acier au chrome vanadium ronde chromée.
- Extrémité sablée.

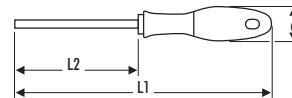

	N°	L1 mm	L2 mm	d mm	Poids g	☒	EAN
E165319	PZ 0	177	75	27	41	10	3258951653197
E165335	PZ 1	205	100	32	69	10	3258951653357
E165337	PZ 2	230	125	32	88	10	3258951653371

TOURNEVIS POUR VIS POZIDRIV® AVEC ÉCROU

- ISO 8764-1 - ISO 8764-2
- Manche ergonomique tri-matière confortable et efficace.
- Code couleur empreinte : bleu.
- Lame en acier au chrome vanadium ronde chromée.
- Extrémité sablée.
- Écrou 6 pans.

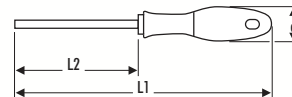

	N°	L1 mm	L2 mm	d mm	Poids g	☒	EAN
E160401	PZ 2	230	125	32	95	5	3258951604014
E160402	PZ 3	266	150	40	165	5	3258951604021
E160403	PZ 4	316	200	40	254	5	3258951604038

TOURNEVIS BOULE POUR VIS POZIDRIV®

- ISO 8764-1 - ISO 8764-2
- Manche ergonomique tri-matière confortable et efficace.
- Code couleur empreinte : bleu.
- Lame en acier au chrome vanadium ronde fraisée, chromée.
- Extrémité sablée.
- Tournevis compact idéal pour les vis difficiles d'accès.

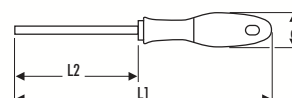

	N°	L1 mm	L2 mm	d mm	Poids g	☒	EAN
E165408	PZ 1	86	30	32	37	5	3258951654088
E165409	PZ 2	86	30	32	42	5	3258951654095





En complément de sa gamme de tournevis tri-matière, EXPERT vous propose une offre alternative en bi-matière.



CARACTÉRISTIQUES

Ergonomie

Manche

Code couleur

Lame

Extrémité sablée

•

Tri-matière

•

Bi-matière

•

Chromée

Zinguée

•

GAMME

Lames standard



Lames longues



Lames courtes



Lames avec écrous



Isolés 1000V



JEUX DE TOURNEVIS - BI-MATIÈRE

JEU DE 10 TOURNEVIS - BI-MATIÈRE - FENTE-PHILLIPS®-POZIDRIV®

- Tournevis pour vis à fente (électricien) : 2,5 x 50 - 3 x 50 - 4 x 100 mm.
- Tournevis pour vis à fente (mécanicien) : 5,5 x 125 - 6,5 x 150 mm.
- Tournevis Phillips® : PH0 x 75 - PH1 x 100 - PH2 x 125.
- Tournevis Pozidriv® [compact] : PZ1 x 100 - PZ2 x 125.



E160924	Poids g 650	📦 5	EAN 3258951609248
---------	----------------	--------	----------------------



JEU DE 7 TOURNEVIS - BI-MATIÈRE - FENTE-PHILLIPS®

- Tournevis pour vis à fente (électricien) : 2,5 x 50 - 3 x 50 - 4 x 100 mm.
- Tournevis pour vis à fente (mécanicien) : 5,5 x 125 - 6,5 x 150 mm.
- Tournevis Phillips® : PH1 x 100 - PH2 x 125.



E160922	Poids g	📦	EAN
E160922	466	5	3258951609224



JEU DE 7 TOURNEVIS - BI-MATIÈRE - FENTE-POZIDRIV®

- Tournevis pour vis à fente (électricien) : 2,5 x 50 - 3 x 50 - 4 x 100 mm.
- Tournevis pour vis à fente (mécanicien) : 5,5 x 125 - 6,5 x 150 mm.
- Tournevis Pozidriv® : PZ1 x 100 - PZ2 x 125.

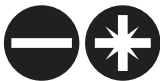

E160923	Poids g	📦	EAN
E160923	466	5	3258951609231



JEU DE 5 TOURNEVIS - BI-MATIÈRE - FENTE-PHILLIPS®

- Tournevis pour vis à fente (électricien) : 3,5 x 75 - 4 x 100 mm.
- Tournevis pour vis à fente (mécanicien) : 5,5 x 125 mm.
- Tournevis Phillips® : PH1 x 100 - PH2 x 125.



E160920	Poids g	📦	EAN
E160920	330	5	3258951609200

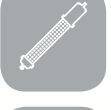



JEUX DE TOURNEVIS - BI-MATIÈRE

JEU DE 5 TOURNEVIS - BI-MATIÈRE - FENTE-POZIDRIV®

- Tournevis pour vis à fente (électricien) : 3,5 x 75 - 4 x 100 mm.
- Tournevis pour vis à fente (mécanicien) : 5,5 x 125 mm.
- Tournevis Pozidriv® : PZ1 x 100 - PZ2 x 125.

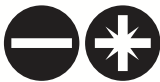

E160921	Poids g	📦	EAN
	330	5	3258951609217

TOURNEVIS - BI-MATIÈRE

TOURNEVIS - BI-MATIÈRE - POUR VIS FENTE ÉLECTRICIEN

- ISO 2380-1 - ISO 2380-2
- Manche ergonomique bi-matière confortable et efficace.
- Lame en acier au chrome vanadium, zinguée.

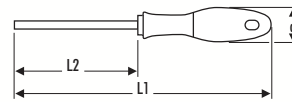
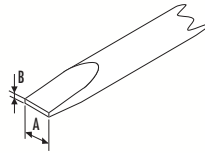

	A x L2 x B mm	L1 mm	d mm	Poids g	📦	EAN
E160250	2,5 x 50 x 0,4	149	20	16	5	3258951602508
E160252	3,5 x 75 x 0,6	177	27	37	10	3258951602522
E160253	4,0 x 100 x 0,8	202	27	43	10	3258951602539

TOURNEVIS - BI-MATIÈRE - POUR VIS FENTE MÉCANICIEN

- ISO 2380-1 - ISO 2380-2
- Manche ergonomique bi-matière confortable et efficace.
- Lame en acier au chrome vanadium, zinguée.

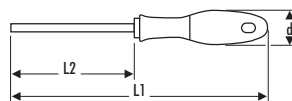
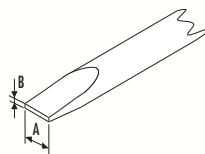

	A x L2 x B mm	L1 mm	d mm	Poids g	📦	EAN
E160254	5,5 x 125 x 1,0	230	32	69	10	3258951602546
E160255	6,5 x 150 x 1,2	266	40	123	10	3258951602553
E160256	8,0 x 175 x 1,6	291	40	177	10	3258951602560



TOURNEVIS - BI-MATIÈRE - POUR VIS PHILLIPS®

- ISO 8764-1 - ISO 8764-2
- Manche ergonomique bi-matière confortable et efficace.
- Lame en acier au chrome vanadium, zinguée.

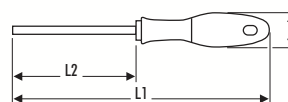

	L1 mm	L2 mm	d mm	Poids g	☒	EAN
E160340	177	75	27	44	10	3258951603406
E160341	205	100	32	69	10	3258951603413
E160342	230	125	32	88	10	3258951603420

TOURNEVIS - BI-MATIÈRE - POUR VIS POZIDRIV®

- ISO 8764-1 - ISO 8764-2
- Manche ergonomique bi-matière confortable et efficace.
- Lame en acier au chrome vanadium, zinguée.

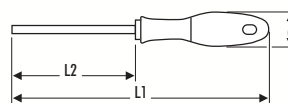

	L1 mm	L2 mm	d mm	Poids g	☒	EAN
E160410	177	75	27	41	10	3258951604106
E160411	205	100	32	69	10	3258951604113
E160412	230	125	32	88	10	3258951604120





MINI TOURNEVIS

MINI TOURNEVIS PLAT

- Manche acétate de cellulose bleu.
- Lame ronde au chrome vanadium, nickelée.
- Agrafe sur E161111.

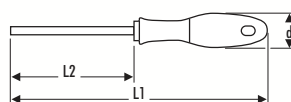
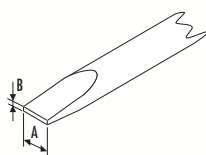

	A x L2 x B mm	L1 mm	L2 mm	d mm	Poids g	☒	EAN
E161110	2,0x35x0,4	75	35	12,5	7	1	3258951611104
E161111	2,5x35x0,4	110	50	13	10	1	3258951611111

CLÉS À DOUILLES EMMANCHÉES

CLÉS À DOUILLE EMMANCHÉES MÉTRIQUES

- ISO 2236 - DIN 3125
- Manche ergonomique bi-matière confortable et efficace.
- Code couleur empreinte : gris.
- Lame en acier au chrome vanadium, chromée.

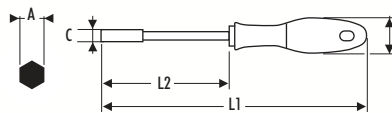

	A mm	L1 mm	L2 mm	C mm	d mm	Poids g	☒	EAN
E121501	5	230	125	8	32	78	1	3258951215012
E121502	5,5	230	125	8,8	32	78	1	3258951215029
E121503	6	230	125	9,4	32	80	1	3258951215036
E121504	7	230	125	11	32	100	1	3258951215043
E121505	8	240	125	12	40	125	1	3258951215050
E121506	9	240	125	13,3	40	132	1	3258951215067
E121507	10	240	125	14,5	40	148	1	3258951215074
E121517	13	240	125	18,5	40	220	1	3258951215173



JEUX DE CLÉS MÂLES

JEU DE 7 CLÉS MÂLES 6 PANS MÉTRIQUES

- Sur support plastique, étui compact et résistant.
- Type couteau de poche.
- Finition brunie.



E469262	Quantité	Contenu	Poids g		EAN
E469262	7	2,5-3-4-5-6-8-10 mm.	250	12	3258954692629

JEU DE 8 CLÉS MÂLES TORX®

- Sur support plastique, étui compact et résistant.
- Type couteau de poche.
- Finition : brunie.



E469263	Quantité	Contenu	Poids g		EAN
E469263	8	T9-T10-T15-T20-T25-T27-T30-T40	156	12	3258954692636





CLÉS MÂLES 6 PANS

JEU DE 9 CLÉS MÂLES LONGUES 6 PANS MÉTRIQUES

- Sur support plastique, étui compact et résistant.
- Clés en acier au chrome vanadium, zinguées.
- Longues.
- Finition : phosphate noir.



	Quantité	Contenu	Poids g		EAN
E113947	9	1,5-2-2,5-3-4-5-6-8-10 mm	350	1	3258951139479

CLÉS MÂLES 6 PANS LONGUES MÉTRIQUES

- ISO 2936 - DIN 911
- Fabriquée en acier au chrome vanadium pour une tenue au couple supérieure aux normes en vigueur.
- Arêtes des faces des extrémités microchanfreinées pour une meilleure tenue dans la tête de vis.
- Finition : phosphate noir.

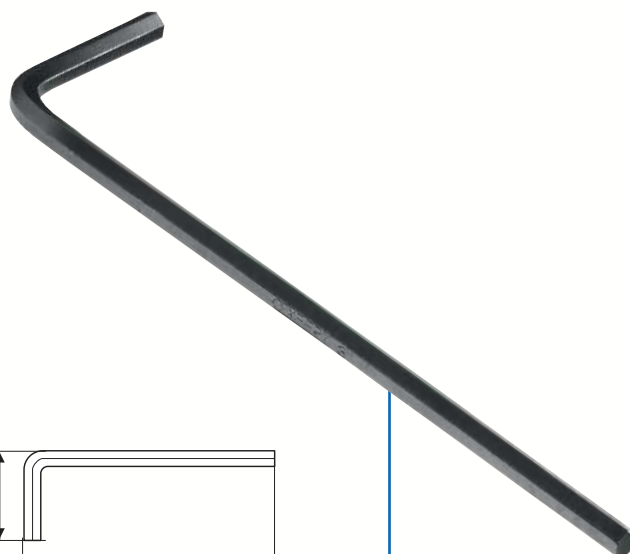

	A mm	L mm	l mm	Poids g		EAN
E113930	1,5	64	16	150	10	3258951139301
E113931	2	77	18	2	10	3258951139318
E113932	2,5	88	21	4	10	3258951139325
E113933	3	93	23	7	10	3258951139332
E113934	4	104	29	13	10	3258951139349
E113935	5	120	33	24	10	3258951139356
E113936	6	141	38	41	10	3258951139363
E113938	8	158	44	81	10	3258951139387
E113939	10	180	50	142	10	3258951139394
E120303	12	202	57	218	5	3258951203033
E120301	9	169	47	108	10	3258951203019
E120302	11	191	53	182	5	3258951203026
E120304	14	229	70	354	1	3258951203040
E120305	17	262	80	562	1	3258951203057



JEU DE 10 CLÉS MÂLES 6 PANS MÉTRIQUES

- Jeu économique.
- Sur support plastique.
- Finition: phosphate noir.

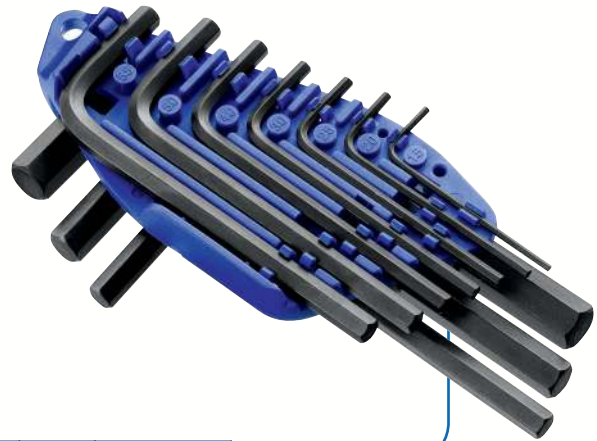

	Quantité	Contenu	Poids g	📦	EAN
E069253	10	2-2,5-3-4-5-6-7-8-9-10 mm	310	12	3258950692531

JEU DE 9 CLÉS MÂLES LONGUES 6 PANS EN POUÇES

- Sur support plastique, étui compact et résistant.
- Clés en acier au chrome vanadium, zinguées.
- Longues.
- Finition : phosphate noir.



	Quantité	Contenu	Poids g	📦	EAN
E121101	9	1/16"-5/64"-3/32"-1/8"-5/32"-3/16"-7/32"-1/4"-3/8"	290	1	3258951211014

JEU DE 9 CLÉS MÂLES TÊTE SPHÉRIQUE 6 PANS MÉTRIQUES

- Sur support plastique, étui compact et résistant.
- Clés en acier au chrome vanadium, zinguées.
- Longues à tête sphérique.
- Finition : phosphate noir.



	Quantité	Contenu	Poids g	📦	EAN
E113976	9	1,5-2-2,5-3-4-5-6-8-10 mm	350	1	3258951139769





CLÉS MÂLES 6 PANS

CLÉS MÂLES 6 PANS LONGUES TÊTE SPHÉRIQUE MÉTRIQUES

→ ISO 2936 - DIN 911

- La tête sphérique permet un débattement jusqu'à 15°, pour un vissage aisé et rapide, dans des endroits difficiles d'accès.
- Elle permet aussi une pénétration rapide et facile dans l'empreinte de la vis.
- Finition : phosphate noir.



	A mm	L mm	l mm	Poids g		EAN
E113964	1,5	64	16	1	10	3258951139646
E113965	2	77	18	2	10	3258951139653
E113966	2,5	88	21	4	10	3258951139660
E113967	3	93	23	8	10	3258951139677
E113968	4	104	29	14	10	3258951139684
E113969	5	120	33	24	10	3258951139691
E113970	6	141	38	36	10	3258951139707
E113972	8	158	44	80	10	3258951139721
E113974	10	180	50	139	10	3258951139745

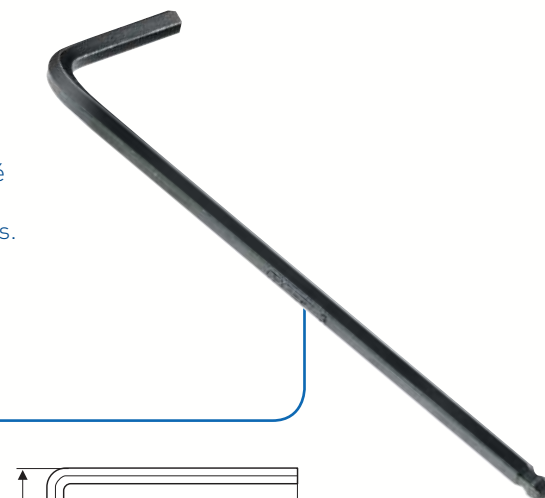

JEU DE 9 CLÉS MÂLES TÊTE SPHÉRIQUE 6 PANS EN POUÇES

- Sur support plastique, étui compact et résistant.
- Clés en acier au chrome vanadium, zinguées.
- Longues à tête sphérique.
- Finition : phosphate noir.



	Quantité	Contenu	Poids g		EAN
E117816	9	1/16"-5/64"-3/32"-1/8"-5/32"-3/16"-7/32"-1/4"-3/8"	290	1	3258951178164



CLÉS MÂLES 6 PANS LONGUES TÊTE SPHÉRIQUE EN POUÇES

→ ISO 2936 - DIN 911

- La tête sphérique permet un débattement jusqu'à 15°, pour un vissage aisé et rapide, dans des endroits difficiles d'accès.
- Elle permet aussi une pénétration rapide et facile dans l'empreinte de la vis.
- Finition : phosphate noir.



	A "	L mm	l mm	Poids g		EAN
E120601	1/16"	78	16	2	5	3258951206010
E120603	3/32"	88	19	5	5	3258951206034
E120602	5/64"	83	17	3	5	3258951206027
E120604	1/8"	98,5	22	8	5	3258951206041
E120605	5/32"	108	25	12	5	3258951206058
E120606	3/16"	119	28,5	20	5	3258951206065
E120607	7/32"	129,5	32	39	5	3258951206072
E120608	1/4"	140	35	50	5	3258951206089
E120609	3/8"	181	44,5	130	5	3258951206096

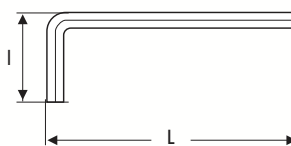



JEU DE 9 CLÉS MÂLES COURTES 6 PANS MÉTRIQUES

- Sur support plastique, étui compact et résistant.
- Clés en acier au chrome vanadium, zinguées.
- Courtes.
- Finition : phosphate noir.



	Quantité	Contenu	Poids g	☒	EAN
E113929	9	1,5-2-2,5-3-4-5-6-8-10 mm.	260	1	3258951139295

CLÉS MÂLES 6 PANS COURTES MÉTRIQUES

- ISO 2936 - DIN 911
- Fabriquée en acier au chrome vanadium pour une tenue au couple supérieure aux normes en vigueur.
- Arêtes des faces des extrémités microchanfreinées pour une meilleure tenue dans la tête de vis.
- Finition : phosphate noir.



	A mm	L mm	l mm	Poids g	☒	EAN
E120101	0,9	41	11	50	10	3258951201015
E113911	1,3	42	14	1	10	3258951139110
E113912	1,5	47	16	1	10	3258951139127
E113913	2	52	18	3	10	3258951139134
E113914	2,5	59	21	3	10	3258951139141
E113915	3	66	23	6	10	3258951139158
E120102	3,5	70	26	7	10	3258951201022
E113916	4	74	29	10	10	3258951139165
E120103	4,5	80	31	13	10	3258951201039
E113917	5	85	33	18	10	3258951139172
E113918	6	96	38	30	10	3258951139189
E113919	7	102	41	43	10	3258951139196
E113920	8	108	44	60	10	3258951139202
E113921	9	114	47	79	10	3258951139219
E113922	10	122	50	104	10	3258951139226
E113923	11	129	53	143	5	3258951139233
E113924	12	137	57	168	5	3258951139240
E113925	13	145	63	212	1	3258951139257
E113926	14	154	70	264	1	3258951139264
E113927	17	177	80	444	1	3258951139271
E113928	19	199	89	555	1	3258951139288





CLÉS MÂLES TORX®

JEU DE 7 CLÉS MÂLES TORX®

- Sur support plastique, étui compact et résistant.
- Clés en acier au chrome vanadium, finition phosphate noir.



E121102	Quantité	Contenu	Poids g	📦	EAN
E121102	7	T10-T15-T20-T25-T27-T30-T40	110	1	3258951211021

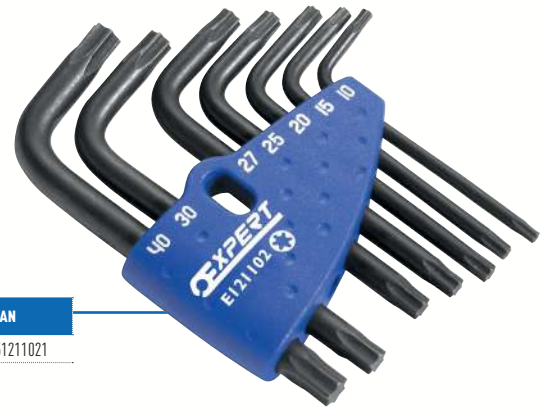

CLÉS MÂLES TORX®

- ACUMENT TMD 702
- Finition : phosphate noir.



	N°	L mm	l mm	Poids g	📦	EAN
E113994	T10	54	20	4	10	3258951139943
E113995	T15	58	22	5	10	3258951139950
E113996	T20	61	24	7	10	3258951139967
E113997	T25	66	25	9	10	3258951139974
E113998	T27	69	27	15	10	3258951139981
E113999	T30	76	30	20	10	3258951139998
E113854	T40	83	33	29	10	3258951138540



JEU DE 7 CLÉS MÂLES RÉSISTORX® SUR SUPPORT PLASTIQUE

- Sur support plastique, étui compact et résistant.
- Clés en acier au chrome vanadium, finition phosphate noir.



E121103	Quantité	Contenu	Poids g	📦	EAN
E121103	7	TT10-TT15-TT20-TT25-TT27-TT30-TT40	110	1	3258951211038



CLÉS MÂLES RESISTORX®

- ACUMENT CID 602
- Finition : phosphate noir.



	N°	L mm	l mm	Poids g	📦	EAN
E113858	TT10	54	20	4	10	3258951138588
E113859	TT15	58	22	5	10	3258951138595
E113860	TT20	61	24	7	10	3258951138601
E113861	TT25	66	25	9	10	3258951138618
E120901	TT27	69	27	15	5	3258951209011
E113862	TT30	76	30	20	10	3258951138625
E113863	TT40	83	33	29	10	3258951138632





CLÉS MÂLES EN T

JEUX DE 7 CLÉS MÂLES EN T EMMANCHÉES 6 PANS MÉTRIQUES

- Clés mâles en T emmanchées 6 pans : 2,5-3-4-5-6-8-10 mm.

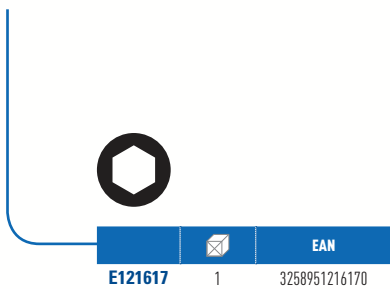

CLÉS MÂLES EN T EMMANCHÉES 6 PANS MÉTRIQUES (1)

- ISO 2936 - DIN 911
- Poignée en T ergonomique pour une utilisation efficace des deux extrémités de la clé.
- Acier au silicium.
- Finition : phosphate noir.

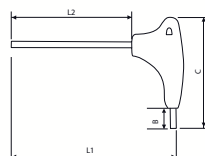
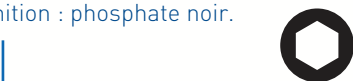

	A mm	L1 mm	L2 mm	B mm	C mm	Poids g		EAN
E121602	2	127	100	10	52	18	18	3258951216026
E121601	2,5	127	100	10	52	20	5	3258951216019
E121603	3	127	100	10	52	21	5	3258951216033
E121604	4	183	150	11	66	47	5	3258951216040
E121605	5	183	150	11	66	60	5	3258951216057
E121606	6	240	200	12	82	112	5	3258951216064
E121607	8	240	200	14	82	165	5	3258951216071
E121608	10	240	200	16	82	233	5	3258951216088

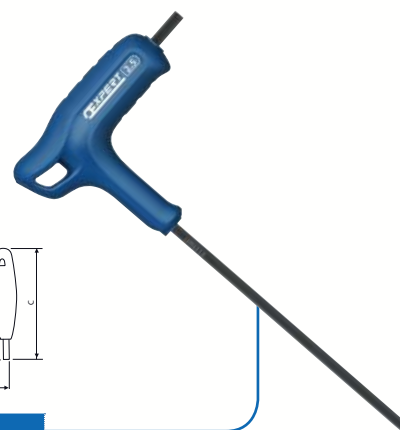

MODULE DE 8 CLÉS MÂLES EN T EMMANCHÉES 6 PANS

- 2 clés mâles en T emmanchées 6 pans : 2,5-3 mm.
- 6 clés mâles en T emmanchées 6 pans à tête sphérique : 4-5-6-7-8-10 mm.
- Plateau vide : E121205.

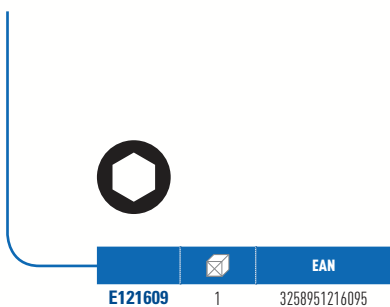



CLÉS MÂLES EN T

JEUX DE 6 CLÉS MÂLES EN T EMMANCHÉES 6 PANS À TÊTE SPHÉRIQUE

→ Clés mâles en T emmanchées 6 pans à tête sphérique : 4-5-6-7-8-10 mm.



	Poids g	📦	EAN
E121616	755	1	3258951216163



CLÉS MÂLES EN T EMMANCHÉES 6 PANS À TÊTE SPHÉRIQUE MÉTRIQUES

→ ISO 2936 - DIN 911

- Poignée en T ergonomique pour une utilisation efficace des deux extrémités de la clé.
- Tête sphérique permettant une inclinaison jusqu'à 15°.
- Acier au silicium.
- Finition : phosphate noir.

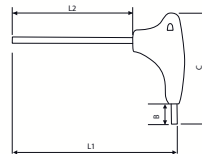

	A mm	L1 mm	L2 mm	B mm	C mm	Poids g	📦	EAN
E121610	4	183	150	11	66	47	5	3258951216101
E121611	5	183	150	12	66	60	5	3258951216118
E121612	6	240	200	12	82	112	5	3258951216125
E121613	7	240	200	13	82	137	5	3258951216132
E121614	8	240	200	14	82	165	5	3258951216149
E121615	10	240	200	16	82	233	5	3258951216156



JEU DE 7 CLÉS MÂLES EN T EMMANCHÉES TORX®

→ Clés mâles en T emmanchées Torx® : T10-T15-T20-T25-T27-T30-T40.



	Poids g	📦	EAN
E121709	355	1	3258951217092





CLÉS MÂLES EN T

MODULE DE 7 CLÉS MÂLES EN T EMMANCHÉES TORX®

- Clés mâles en T emmanchées Torx® : T10-T15-T20-T25-T27-T30-T40.
- Plateau vide : E121214.



	Poids g		EAN
E121708	547	1	3258951217085

CLÉS MÂLES EN T EMMANCHÉES TORX®

- ACUMENT TMD 702
- Poignée en T ergonomique pour une utilisation efficace des deux extrémités de la clé.
- Acier au silicium.
- Finition : phosphate noir.

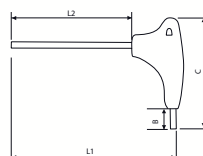

	N°	L1 mm	L2 mm	B mm	C mm	Poids g		EAN
E121701	T10	126	100	10	52	18	5	3258951217016
E121702	T15	126	100	10	52	25	5	3258951217023
E121703	T20	133	100	11	66	35	5	3258951217030
E121704	T25	133	100	12	66	50	5	3258951217047
E121705	T27	133	100	12	66	55	5	3258951217054
E121706	T30	191	150	12	82	60	5	3258951217061
E121707	T40	191	150	14	82	112	5	3258951217078





CLÉS MÂLES EN T

CLÉS MÂLES EN T 6 PANS

- UNI 2936 - ISO 2936 - DIN ISO 2936
- Précision dimensionnelle assurant un couplage parfait avec la vis.
- Corps en acier au chrome vanadium.
- Finition : chrome, brillante.

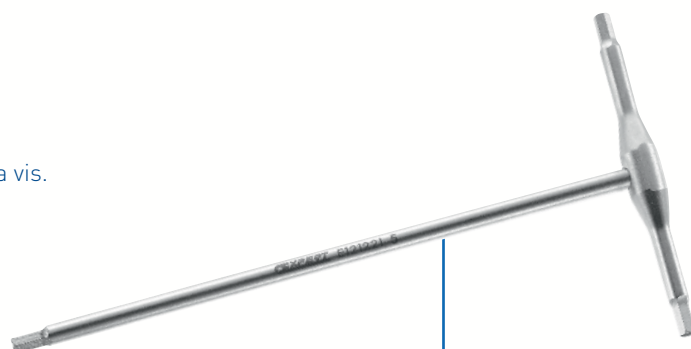
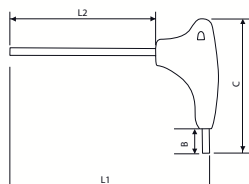

	A mm	L1 mm	L2 mm	C mm	Poids g	☒	EAN
E121215	2	125	117	62.5	19	5	3258951212158
E121216	2.5	125	117	62.5	19	5	3258951212165
E121217	3	150	142	75	24	5	3258951212172
E121218	3.5	150	142	75	24	5	3258951212189
E121219	4	180	170	90	62	5	3258951212196
E121220	4.5	180	170	90	62	5	3258951212202
E121221	5	210	198	105	99	5	3258951212219
E121222	6	210	196	105	135	5	3258951212226
E121223	7	210	196	105	135	5	3258951212233
E121224	8	250	234	125	200	5	3258951212240
E121226	10	300	279.5	150	410	5	3258951212264
E121227	12	320	296	160	590	5	3258951212271
E121228	14	340	312	170	830	5	3258951212288

JEU DE CLÉS MÂLES EN T 6 PANS



	Contenu	Poids g	☒	EAN
E121229	2,5 - 3 - 4 - 5 - 6 - 8 mm.	550	1	3258951212295
E121230	2 - 2.5 - 3 - 3.5 - 4 - 4.5 - 5 - 6 - 7 - 8 - 10 - 12 - 14 mm.	2610	1	3258951212301



TOURNEVIS À FRAPPER

COFFRET TOURNEVIS À FRAPPER - 12 PIÈCES

- Déblocage rapide et en toute sécurité des vis grippées, rouillées ou collées.
- Livré en boîte métallique.
- Contenu :
 - Tournevis à frapper 1/2".
 - Douille porte-embouts 1/2" - 5/16".
 - Embout extracteur n°3, L.67 mm.
 - Embout extracteur n°4, L.71 mm.
 - 2 embouts pour vis à fente 8-10 mm, L.36 mm.
 - 2 embouts pour vis Phillips® 2-3 mm, L.36 mm.
 - 2 embouts pour vis à fente 8-10 mm, L.80 mm.
 - 2 embouts pour vis Philips® 2-3 mm, L.80 mm.



E230301	Poids g	📦	EAN
1250	1	3258952303015	

EMBOUTS DE VISSAGE

MODULE DE VISSAGE

- Boîte d'embouts et accessoires 49 pièces contenant :
 - Embouts fente : 4-4,5-5,5-6,5x2-8 mm.
 - Embouts Phillips® : PH1x2-PH2x3-PH3.
 - Embouts Pozidriv® : PZ1x2-PZ2x3-PZ3x2.
 - Embouts Torx® : T10x2-T15x2-T20x2-T25x2-T30x2.
 - Embouts ResisTorx® : TT10-TT15x2-TT20x2-TT25x2-TT30x2-TT40.
 - Embouts 6 pans : 2-3x2-4x2-5x2-6x2 mm.
 - Porte-embouts magnétique à bague de verrouillage.
 - Tournevis porte-embouts revolver à cliquet + 7 embouts :
 - fente : 4-5,5-6 mm,
 - Phillips® : PH1-PH2, Pozidriv® : PZ1-PZ2.
 - Jeu de 9 clés mâles 6 pans métriques sur étui : 1,5-2-2,5-3-4-5-6-8-10 mm.
 - Jeu de 7 clés mâles Torx® sur étui : T10-T15-T20-T25-T27-T30-T40 mm.
 - Porte douille 1/4".
 - Plateau vide : E121106.



E121105	Quantité	Poids g	📦	EAN
5	1392	1	3258951211052	





EMBOUTS DE VISSAGE

COFFRET D'EMBOUTS 1/4" - 100 PIÈCES

- Embouts fente : 3 - 4 - 4.5 - 5 - 5.5 - 6 - 6.5 - 7 - 8 mm.
- Embouts Phillips® : PH00 - PH0 - PH1x2 - PH2x2 - PH3 - PH4.
- Embouts Pozidriv® : PZ1 - PZ2x2 - PZ3 - PZ4.
- Embouts 6 pans métriques : 1.5 - 2 - 2.5 - 3 - 4 - 5 - 5.5 - 6 - 7 - 8 mm.
- Embouts 6 pans en pouces : 1/16" - 5/64" - 3/32" - 7/64" - 1/8" - 9/64" - 5/32" - 3/16" - 7/32" - 1/4".
- Embouts Tri-wing® : #1 - #2 - #3 - #4.
- Embouts Spanner® : #4 - #6 - #8 - #10 - #12.
- Embouts Torq-set® : #6 - #8 - #10.
- Embouts Carré Robertson : #0 - #1 - #2x2 - #3.
- Embouts Papillon : 1/8" - 5/32" - 3/16" - 1/4" - 5/16".
- Embouts XZN® : M5 - M6 - M8.
- Embouts Torx® : T8 - T9 - T10 - T15 - T20 - T25 - T27 - T30 - T40 - T45.
- Embouts 6 pans avec protection, métriques : 2 - 2.5 - 3 - 4 - 5 - 6mm.
- Embouts 6 pans avec protection, en pouce : 5/64" - 3/32" - 7/64" - 1/8" - 9/64" - 5/32".
- Embouts Resistorx® : TT8 - TT10 - TT15 - TT20 - TT25 - TT27 - TT30 - TT35 - TT40.
- Porte-embouts magnétique 1/4" [E113648].
- Porte-embouts à verrouillage 1/4" [E168733].



E131709	Quantité	Poids g		EAN
E131709	100	902	1	3258951317099

COFFRET D'EMBOUTS 1/4" - 49 PIÈCES

- Embouts fente : 4-4,5-5,5-6,5x2-8 mm.
- Embouts Phillips® : PH1x2-PH2x3-PH3.
- Embouts Pozidriv® : PZ1x2-PZ2x3-PZ3x2.
- Embouts Torx® : T10x2-T15x2-T20x2-T25x2-T30x2.
- Embouts ResisTorx® : TT10-TT15x2-TT20x2-TT25x2-TT30x2-TT40.
- Embouts 6 pans : 2-3x2-4x2-5x2-6x2 mm.
- Porte-embouts à bague de verrouillage.



E131701	Quantité	Poids g		EAN
E131701	49	392	10	3258951317013

COFFRET D'EMBOUTS ET DOUILLES 1/4" - 39 PIÈCES

- Embouts fente : 4-5,5-6,5-8 mm.
- Embouts Phillips® : PH1-PH2x2-PH3.
- Embouts Pozidriv® : PZ1-PZ2-PZ3.
- Embouts Torx® : T8-T10-T15-T20-T25-T30-T40.
- Embouts ResisTorx® : TT10-TT15-TT20-TT25-TT27-TT30-TT40.
- Embouts 6 pans : 3-4-5-6 mm.
- Porte-embouts à bague de verrouillage.
- Douilles 6 pans : 6-7-8-10-11-12-13 mm.
- Adaptateur douilles.
- Mini cliquet.



E131705	Quantité	Poids g		EAN
E131705	39	445	10	3258951317051



COFFRET D'EMBOUS 1/4" - 32 PIÈCES

- Embouts fente : 4-5,5-6,5-8 mm.
- Embouts Phillips® : PH1-PH2-PH3.
- Embouts Pozidriv® : PZ1-PZ2-PZ3.
- Embouts Torx® : T8-T10-T15-T20x2-T25x2-T30-T40.
- Embouts ResisTorx® : TT10-TT15-TT20-TT25-TT27-TT30-TT40.
- Embouts 6 pans : 3-4-5-6 mm.
- Mini cliquet.
- Porte-embouts à bague de verrouillage.



E131702	Quantité	Poids g	📦	EAN
	32	367	10	3258951317020



COFFRET D'EMBOUS 1/4" - 19 PIÈCES

- Embouts fente : 4-4,5-5,5 mm.
- Embouts Phillips® : PH1-PH2.
- Embouts Pozidriv® : PZ1-PZ2-PZ3.
- Embouts Torx® : T10-T15-T20-T25-T30-T40.
- Embouts 6 pans : 3-4-5-6 mm.
- Porte-embouts magnétique.



E113901	Quantité	Poids g	📦	EAN
	19	188	20	3258951139011



COFFRET D'EMBOUS 1/4" - 61 PIÈCES

- Embouts fente : 4 mm x 3 - 6 mm x 3.
- Embouts Phillips® : PH1 x 3 - PH2 x 6 - PH3 x 3.
- Embouts Pozidriv® : PZ1 x 3 - PZ2 x 6 - PZ3 x 3.
- Embouts 6 pans métriques : 4 mm x 3 - 5 mm x 3 - 6 mm x 3.
- Embouts Torx® : T10 x 3 - T15 x 3 - T20 x 3 - T25 x 3 - T27 x 3 - T30 x 3 - T40 x 3.
- Porte-embouts magnétique 1/4".



E131710	Quantité	Poids g	📦	EAN
	61	445	1	3258951317105





EMBOUS DE VISSAGE

EMBOUS À FENTE 25 MM - 1/4"

→ ISO 1173 - ISO 2380-1 - ISO 2351-1



	A mm	Taille Hexagonale "	Quantité	Poids g	✉	EAN
E130101	4	1/4	6	42	20	3258951301012
E130103	5,5	1/4	6	46	20	3258951301036
E130104	6,5	1/4	6	46	20	3258951301043
E130102	4,5	1/4	6	42	20	3258951301029
E130105	8	1/4	6	63	20	3258951301050



EMBOUS TORSION PHILLIPS® 25 MM - 1/4"

→ ISO 1173 - ISO 8764-1 - ISO 2351-2



	N°	Taille Hexagonale "	Quantité	Poids g	✉	EAN
E113685	PH 1	1/4	6	42	20	3258951136850
E113686	PH 2	1/4	6	46	20	3258951136867
E113687	PH 3	1/4	6	50	20	3258951136874



EMBOUS TORSION POZIDRIV® 25 MM - 1/4"

→ ISO 1173 - ISO 8764-1 - ISO 2351-2



	N°	Taille Hexagonale "	Quantité	Poids g	✉	EAN
E113631	PZ 1	1/4	6	42	20	3258951136317
E113632	PZ 2	1/4	6	46	20	3258951136324
E113633	PZ 3	1/4	6	50	20	3258951136331



EMBOUS 6 PANS 25 MM - 1/4"

→ ISO 1173 - ISO 2936 - ISO 2351-3



	A mm	Taille Hexagonale "	Quantité	Poids g	✉	EAN
E113650	2	1/4	6	50	20	3258951136508
E113651	2,5	1/4	6	54	20	3258951136515
E113652	3	1/4	6	54	20	3258951136522
E117768	4	1/4	6	54	20	3258951177686
E113654	5	1/4	6	54	20	3258951136546
E113655	6	1/4	6	63	20	3258951136553
E113656	7	1/4	6	75	20	3258951136560
E113657	8	1/4	6	75	20	3258951136577
E113658	10	1/4	6	88	20	3258951136584





EMBOUS TORX® 25 MM - 1/4"

→ ISO 1173



	N°	Taille Hexagonale "	Quantité	Poids g	📦	EAN
E117771	T6	1/4	3	33	20	3258951177716
E117772	T7	1/4	3	33	20	3258951177723
E117773	T8	1/4	3	38	20	3258951177730
E117774	T9	1/4	3	38	20	3258951177747
E117775	T10	1/4	3	38	20	3258951177754
E117776	T15	1/4	3	38	20	3258951177761
E117777	T20	1/4	3	38	20	3258951177778
E117778	T25	1/4	3	38	20	3258951177785
E117779	T30	1/4	3	38	20	3258951177792
E117780	T40	1/4	3	42	20	3258951177808



EMBOUS RESISTORX® 25 MM - 1/4"

→ ISO 1173



	N°	Taille Hexagonale "	Quantité	Poids g	📦	EAN
E117781	TT10	1/4	3	38	20	3258951177815
E117782	TT15	1/4	3	38	20	3258951177822
E117783	TT20	1/4	3	38	20	3258951177839
E117784	TT25	1/4	3	38	20	3258951177846
E117785	TT27	1/4	3	38	20	3258951177853
E117786	TT30	1/4	3	38	20	3258951177860
E117787	TT40	1/4	3	38	20	3258951177877



EMBOUS PHILLIPS® 50 MM - 1/4"

→ ISO 1173 - ISO 8764-1 - ISO 2351-2



	N°	Taille Hexagonale "	Quantité	Poids g	📦	EAN
E113691	PH 1	1/4	6	70	20	3258951136911
E113692	PH 2	1/4	6	76	20	3258951136928
E113693	PH 3	1/4	6	82	20	3258951136935



EMBOUS POZIDRIV® 50 MM - 1/4"

→ ISO 1173 - ISO 8764-1 - ISO 2351-2



	N°	Taille Hexagonale "	Poids g	📦	EAN
E113637	PZ 1	1/4	70	20	3258951136379
E113638	PZ 2	1/4	76	20	3258951136386
E113639	PZ 3	1/4	82	20	3258951136393





EMBOUS DE VISSAGE

EMBOUS 6 PANS 50 MM - 1/4"

→ ISO 1173 - ISO 2936 - ISO 2351-3



	A mm	Quantité	Poids g	☒	EAN
E113659	3	6	70	20	3258951136591
E113660	4	6	76	20	3258951136607
E113661	5	6	82	20	3258951136614
E113662	6	6	88	20	3258951136621



DOUILLES MAGNÉTIQUES POUR VIS 6 PANS

→ ISO 1173 - ISO 691 - ISO 1711-1

→ Maintien de la vis par aimant.



	A mm	L mm	Poids g	☒	EAN
E113643	7	65	45	24	3258951136430
E113644	8	65	45	24	3258951136447
E113645	9	65	45	24	3258951136454
E113646	10	65	51	24	3258951136461
E131608	13	65	46	24	3258951316085



PORTE-EMBOUS ET ACCESSOIRES

TOURNEVIS PORTE-EMBOUS 1/4"

→ ISO 1173 - DIN 3126

→ Poignée directement moulée sur la lame : extrêmement fiable et durable.

→ Poignée soft grip antidérapante.

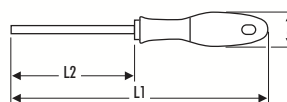

	L1 mm	L2 mm	d mm	Poids g	☒	EAN
E165490	230	125	32	130	5	3258951654903

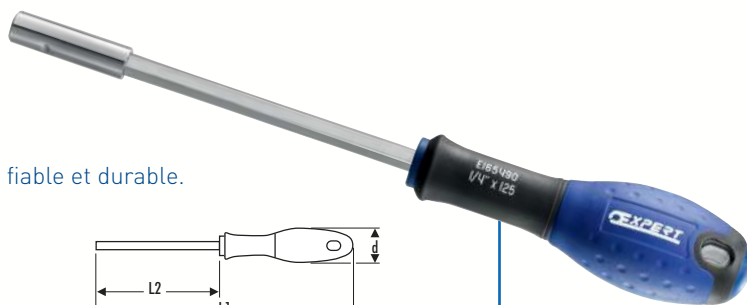

MINI PORTE-EMBOUS À CLIQUET 1/4"

→ ISO 1173

	L mm	Poids g	☒	EAN
E131601	91	54	20	3258951316016





COFFRET DE VISSAGE 1/4" AVEC TOURNEVIS REVOLVER – 59 PIÈCES

- Tournevis porte embouts revolver à cliquet (E160802).
- Embouts fente : 3 – 4x3 – 4.5 – 5 – 5.5x2 – 6 – 6.5x2 – 8 mm.
- Embouts Phillips® : PH1x3 – PH2x4 – PH3.
- Embouts Pozidriv® : PZ1x3 – PZ2x3 – PZ3.
- Embouts 6 pans : 2x2 – 3 – 4x2 – 5x2 – 6x2 mm.
- Embouts Torx® : T10 – T15x2 – T20x2 – T25x2 – T30x2 – T40x2.
- Embouts Resistorx® : TT10 – TT15x2 – TT20x2 – TT25x2 – TT30x2 – TT40.



E160804	Poids g	📦	EAN
891	1	3258951608043	

TOURNEVIS PORTE-EMBOUTS REVOLVER À CLIQUET

- Tournevis porte embouts revolver à cliquet.
- Réservoir 6 embouts.
- Ouverture par pression simultanée de 2 boutons.
- 2 positions de vissage : traditionnelle et position revolver pour une puissance de vissage décuplée.
- Livré avec : Fente : 4-5,5-6,5 mm, Phillips® : PH1-PH2, Pozidriv® : PZ1-PZ2.



E160802	Taille Hexagonale "	Poids g	📦	EAN
1/4	320	10	3258951608029	





PORTE-EMBOUTS ET ACCESSOIRES

TOURNEVIS PORTE-EMBOUTS À CLIQUET

- Réservoir 6 embouts.
- Ouverture par pression simultanée de 2 boutons.
- Livré avec : Fente : 4-5,5-6,5 mm, Phillips® : PH1-PH2, Pozidriv® : PZ1-PZ2.



E160801	1/4	Poids g	10	EAN
		300		3258951608012

MINI TOURNEVIS PORTE-EMBOUTS À CLIQUET

- Livré avec 1 réservoir de 3 embouts :
- Fente : 5,5 mm.
- Phillips® : PH2.
- Pozidriv® : PZ2.



E160803	1/4	Poids g	10	EAN
		170		3258951608036

TOURNEVIS PORTE-EMBOUTS TURN 6

- Manche en acétate de cellulose transparent.
- Manche de prise directe avec l'embout, évitant toute perte de puissance lors de serrages importants.
- Lame nickelée équipée d'un adaptateur magnétique chromé.
- Bouchon en élastomère.
- Livré avec : Fente : 4,5-6,5, Phillips® : PH1-PH2, Pozidriv® : PZ1-PZ2.



E161115	Poids g	1	EAN
	200		3258951611159



TOURNEVIS PORTE-LAMES

- Manche réservoir en acétate.
- Mandrin en laiton.
- Lames rondes nickelées.
- E161112 livré avec : fente 2,0 - 3,0 - 3,5.
- E161113 livré avec : fente 3,5 - 5,0, PH1, 1 pointe.



	L mm	Poids g	📦	EAN
E161112	135	28	1	3258951611128
E161113	155	58	1	3258951611135

PORTE-EMBOUITS À VERROUILLAGE 1/4"

→ ISO 1173



	L mm	Poids g	📦	EAN
E168733	60	28	20	3258951687338

PORTE-EMBOUITS MAGNÉTIQUE 1/4"

→ ISO 1173



	L mm	Poids g	📦	EAN
E113648	60	22	20	3258951136485
E131609	120	41	1	3258951316092

PORTE-DOUILLES 1/4"

→ ISO 1173 - ISO 1174-1



	L mm	Poids g	📦	EAN
E113649	50	29	24	3258951136492



SERRAGE CONTRÔLÉ





Clés dynamométriques

P.138

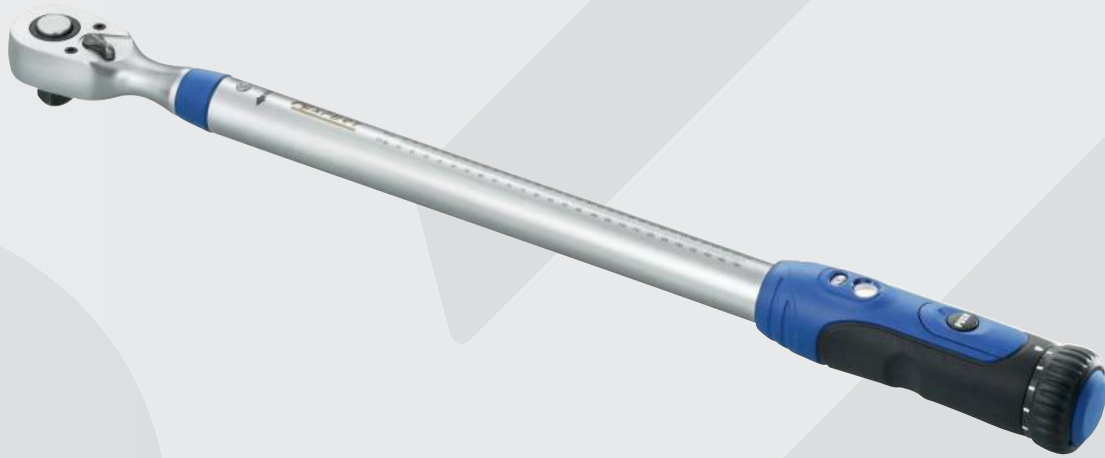

Multiplicateur de couple

P.139





CLÉS DYNAMOMÉTRIQUES

CLÉS DYNAMOMÉTRIQUES

- ISO 6789
- Précision : +/- 4%.
- Poignée confortable.
- Lecture directe de la valeur de couple.
- Rapide et facile à régler.
- Endurance prouvée.
- Livré avec certificat d'étalonnage.

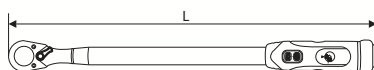

	□	N.m	L mm	Poids g	☒	EAN
E100105	1/4"	5 - 25	323	760	1	3258951001059
E100106	3/8"	10 - 50	400	988	1	3258951001066
E100107	1/2"	20 - 100	400	988	1	3258951001073
E100108	1/2"	40 - 200	517	1360	1	3258951001080
E100109	1/2"	60 - 340	620	1730	1	3258951001097
E100110	3/4"	150 - 750	1200	5850	1	3258951001103



KITS DE RÉPARATION DE CLIQUETS

- E100501 : pour clé dynamométrique 1/4" E100105.
- E100502 : pour clés dynamométriques 3/8" E100106.
- E100503 : pour clés dynamométriques 1/2" E100108, E100112 et E100113.
- E100504 : pour clé dynamométrique 3/4" E100110.
- E100505 : pour clé dynamométrique 1/2" E100107.
- E100506 : pour clé dynamométrique 1/2" E100109.



	☒	EAN
E100501	1	3258951005019
E100502	1	3258951005026
E100503	1	3258951005026
E100504	1	3258951005026
E100505	1	3258951005040
E100506	1	3258951005040

MULTIPLICATEURS DE COUPLE

MULTIPLICATEURS DE COUPLE

- Serrage et desserrage puissant.
- Douille fusible.
- Un bras de réaction droit.
- Un bras de réaction à 90°.



	☒	Ratio	N.m entrée	N.m sortie	Poids g	☒	EAN
E100103	1/2" x 3/4"	6,5	231	1500	6200	1	3258951001035
E100104	1/2" x 1"	12	208	2500	8600	1	3258951001042

DOUILLES FUSIBLES

	N.m	Poids g	☒	EAN
E100203	1500	70	1	3258951002032
E100204	2500	70	1	3258951002049



OUTILLAGE ÉNERGISÉ





Clés à chocs

P.142



Perceuse

P.144



Meuleuses

P.145



Ponceuse

P.146



Riveteuse

P.146



Cliquets

P.146



Douilles impact 3/8"

P.148



Douilles impact 1/2"

P.148



Douilles impact 3/4"

P.153



Douilles impact 1"

P.156





CLÉS À CHOCS

CLÉ À CHOCS 1/2" COMPACTE

- Construction compacte pour accéder aux zones difficiles à atteindre.
- Couple : 678 N.m au desserrage.
- Gaine caoutchouc sur poignée.
- Gâchette progressive.
- Réglage de puissance: 3.
- Diamètre tuyau : 3/8" - 10 mm.
- Connexion outil : 1/4".



	Poids kg		EAN
E230104	1,6	1	3258952301042

CLÉ À CHOCS 1/2"

- Mécanisme de frappe double marteau.
- Couple : 814 N.m au desserrage.
- Gaine caoutchouc sur poignée.
- Gâchette progressive.
- Réglage de puissance : 5.
- Diamètre tuyau : 3/8" - 10 mm.
- Connexion outil : 1/4".



	Poids kg		EAN
E230110	2,7	1	3258952301103

SUPPORT MAGNÉTIQUE RANGE OUTILS

- 4 crochets pour poser des douilles jusqu'au carré 1/2".
- Anneau pour clé à chocs.
- Support pour clé dynamométrique ou cliquet.



		EAN
E231015	1	3258952310150



CLÉ À CHOCS 3/4" - 1017 N.M

- Mécanisme de frappe double marteau durable.
- Couple : 1017 N.m au desserrage.
- La gaine caoutchouc sur la poignée permet un travail confortable et isole du froid.
- Echappement par la poignée.
- Gâchette progressive.
- Inverseur facile d'accès intégrant 3 niveaux de puissance au serrage.
- Diamètre tuyau : 3/8" - 10 mm.
- Connexion outil : 1/4".



	Poids kg		EAN
E230115	2,9	1	3258952301158

CLÉ À CHOCS 3/4" - 1400 N.M

- Mécanisme de frappe double marteau durable.
- Couple : 1400 N.m au desserrage.
- La gaine caoutchouc sur la poignée permet un travail confortable et isole du froid.
- Echappement par la poignée.
- Gâchette progressive.
- Inverseur facile d'accès intégrant 3 niveaux de puissance au serrage.
- Diamètre tuyau : 3/8" - 10 mm.
- Connexion outil : 1/4".



	Poids kg		EAN
E230116	4,75	1	3258952301165

CLÉ À CHOCS PISTOLET 1"

- Mécanisme de frappe durable de type pinless rocking dog.
- Couple : 2170 N.m au desserrage.
- Echappement latéral.
- Gâchette progressive.
- Inverseur facile d'accès intégrant 3 niveaux de puissance au serrage.
- Diamètre tuyau : 3/4" - 19 mm.
- Connexion outil : 1/2".

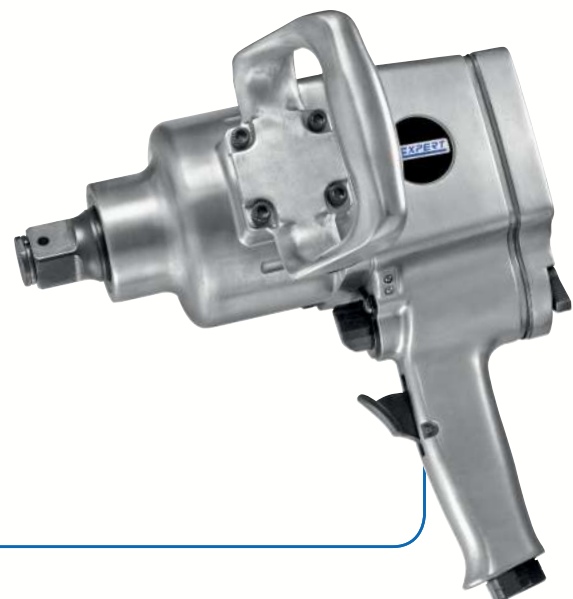

	Poids kg		EAN
E230120	12	1	3258952301202





CLÉS À CHOCS

CLÉ À CHOCS 1"

- Mécanisme de frappe durable type pinless rocking dog.
- Couple : 2170 N.m au desserrage.
- Gaine caoutchouc sur poignée.
- Gâchette progressive.
- Réglage de puissance : 3.
- Diamètre tuyau : 3/4" - 19 mm.
- Connexion outil : 1/2".



	Poids kg		EAN
E230125	9,8	1	3258952301257

CLÉ À CHOCS BROCHE LONGUE 1"

- Mécanisme de frappe durable de type pinless rocking dog.
- Couple : 2170 N.m au desserrage.
- Échappement latéral.
- Gâchette progressive.
- Inverseur facile d'accès intégrant 3 niveaux de puissance en serrage.
- Diamètre tuyau : 3/4" - 19 mm.
- Connexion outil : 1/2".

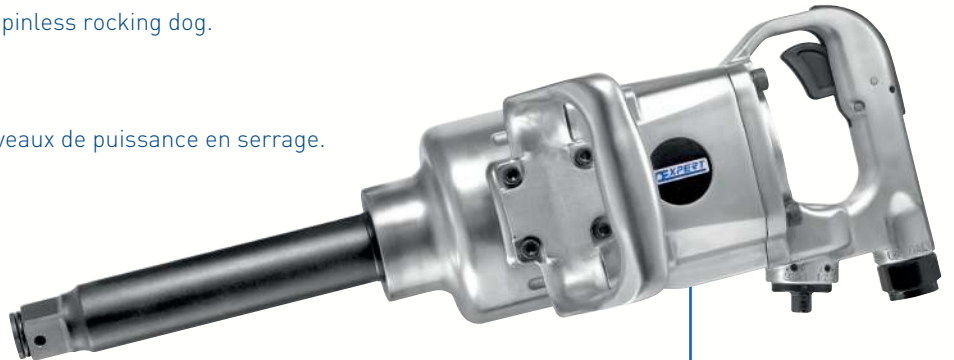

	Poids kg		EAN
E230126	9,8	1	3258952301257

PERCEUSE

PERCEUSE RÉVERSIBLE 3/8"

- Mandrin à serrage rapide.
- Capacité du mandrin : 3/8" - 10 mm.
- Vitesse à vide : 1 800 tr/min.
- Puissance : 0,3 kW.
- Diamètre tuyau : 3/8" - 10 mm.
- Connexion outil : 1/4".



	Poids kg		EAN
E230402	1,170	1	3258952304029



MEULEUSES

MEULEUSE DROITE 1/4"

- Vitesse à vide : 25 000 tr/min.
- Gâchette progressive pour un meilleur contrôle de la vitesse.
- Puissance : 0,3 kW.
- Diamètre tuyau : 3/8" - 10 mm.
- Connexion outil : 1/4".



E230502	Poids g	📦	EAN
	562	1	3258952305026

MEULEUSE D'ANGLE À PINCE 1/4"

- Vitesse à vide : 20 000 tr/min.
- Gâchette progressive pour un meilleur contrôle de la vitesse.
- Puissance : 0,25 kW.
- Diamètre tuyau : 3/8" - 10 mm.
- Connexion outil : 1/4".



E230503	Poids g	📦	EAN
	502	1	3258952305033

MEULE D'ÉBARDAGE DIAM.125 - M14

- Vitesse à vide : 11000 tr/min.
- Gâchette de sécurité.
- Puissance : 0,75 kW.
- Diamètre tuyau : 3/8" - 10 mm.
- Connexion outil : 1/4".



E230508	Poids kg	📦	EAN
	1,90	1	3258952305088





PONCEUSE

PONCEUSE ORBITALE 15 MM - 5 MM

- Vitesse à vide : 10 000 tr/min.
- Vitesse variable par la gâchette.
- Echappement d'air tournant sur 360°
- Diamètre tuyau : 3/8" - 10 mm.
- Connexion outil : 1/4".



	Poids kg		EAN
E230603	0,65	1	3258952306030

RIVETEUSE

RIVETEUSE PNEUMATIQUE

- Pour rivets de 2,4-3,2-4,0-4,8 mm.
- Pour une utilisation avec de l'acier, de l'aluminium, du cuivre ou d'autres matériaux tendres.
- Force de traction : 9 kN.
- Gâchette large pour faciliter l'utilisation.
- Course de l'outil : 14 mm.
- Diamètre tuyau : 3/8" - 10 mm.
- Connexion outil : 1/4".



	Poids kg		EAN
E230901	1,720	1	3258952309017

CLIQUETS

CLIQUET PNEUMATIQUE 1/4" "MINI"

- Conception compacte pour travailler dans un environnement confiné.
- Vitesse à vide : 250 tr/min.
- Couple maximum : 27 N.m.
- Echappement latéral.
- Inversion facile à la tête du cliquet.
- Diamètre tuyau : 1/4" - 6 mm.
- Connexion outil : 1/4".



	L mm	d mm	Poids kg		EAN
E230201	175,5	36	0,52	1	3258952302018



CLIQUET PNEUMATIQUE 3/8" "MINI"

- Conception compacte pour travailler dans un environnement confiné.
- Vitesse à vide : 250 tr/min.
- Couple maximum : 54 N.m.
- Echappement latéral.
- Inversion facile à la tête du cliquet.
- Diamètre tuyau : 1/4" - 6 mm.
- Connexion outil : 1/4".



	L mm	d mm	Poids kg	☒	EAN
E230202	175,5	36	0,52	1	3258952302025

CLIQUET PNEUMATIQUE 3/8"

- Mécanisme robuste pour une utilisation quotidienne.
- Vitesse à vide : 150 tr/min.
- Couple maximum : 68 N.m.
- Echappement latéral.
- Inversion facile à la tête du cliquet.
- Diamètre tuyau : 3/8" - 10 mm.
- Connexion outil : 1/4".



	L mm	L1 mm	d mm	Poids kg	☒	EAN
E230203	267	110,8	40,5	1,17	1	3258952302032

CLIQUET PNEUMATIQUE 1/2"

- Mécanisme robuste pour une utilisation quotidienne.
- Vitesse à vide : 150 tr/min.
- Couple maximum : 68 N.m.
- Echappement latéral.
- Inversion facile à la tête du cliquet.
- Diamètre tuyau : 3/8" - 10 mm.
- Connexion outil : 1/4".



	L mm	L1 mm	d mm	Poids kg	☒	EAN
E230204	267	110,8	40,5	1,17	1	3258952302049





DOUILLES IMPACT 3/8"

JEU DE DOUILLES IMPACT 3/8" - 9 PIÈCES

- Douilles impact 3/8" : 8-9-10-11-12-13-14-17-19 mm.
- Livré avec joncs et goupilles de sécurité.
- Livré sur rack métallique.



E041601	3/8"	Poids kg	1	EAN
		1,30		3258950416014

COMPOSITIONS DE DOUILLES IMPACT 1/2"

COFFRET DE DOUILLES LONGUES IMPACT 1/2" - 14 PIÈCES

- Douilles longues impact 1/2" 6 pans : 10-11-12-13-14-16-17-19-21-22-24-27-30-32 mm.
- Livré avec joncs et goupilles de sécurité.
- Livré en boîte à fermoirs métalliques, compatible tiroir de servante.



E041602	1/2"	Poids kg	1	EAN
		4,65		3258950416021

COFFRET DE DOUILLES ET ACCESSOIRES IMPACT 1/2" - 17 PIÈCES

- Douilles impact 1/2" 6 pans : 10-11-12-13-14-15-16-17-18-19-21-22-24-27-30-32 mm.
- Rallonge impact 1/2" : 125 mm.
- Livré avec joncs et goupilles de sécurité.
- Livré en boîte à fermoirs métalliques, compatible tiroir de servante.



E041603	1/2"	Poids kg	1	EAN
		3,80		3258950416038



MODULE MOUSSE IMPACT 1/2" - 11 PIÈCES

- Clé à chocs compacte 1/2".
- Douilles impact 1/2" - 6 pans - métriques: 11-12-13-17-19-21-22-24-27 mm.
- Rallonge impact 1/2": 125 mm.
- 2 lots de 5 joncs et 5 goupilles pour douilles impact 1/2" : E117881 : 8 à 14 mm. E117884 : 15 à 32 mm.
- Plateau vide : E231105.



E231101	1/2"	Poids g	1	EAN
		3,2		3258952311010

MODULE MOUSSE IMPACT 1/2" - 10 PIÈCES

- Clé à chocs 1/2".
- Douilles longues impact 1/2" - 6 pans - métriques: 13-16-17-18-19-21-22-24 mm.
- Rallonge impact 1/2" : 125 mm.
- 2 lots de 5 joncs et 5 goupilles pour douilles impact 1/2" : E117881 : 8 à 14 mm. E117884 : 15 à 32 mm.
- Plateau vide : E231106.



E231102	1/2"	Poids kg	1	EAN
		5,2		3258952311027





COMPOSITIONS DE DOUILLES IMPACT 1/2"

MODULE DE DOUILLES ET ACCESSOIRES IMPACT 1/2" - 26 PIÈCES

- Douilles impact 1/2" 6 pans : 10-11-12-13-14-15-16-17-18-19-21-22-24 mm.
- Douilles Impact Torx® : E10-E12-E14-E16-E18-E20-E24.
- Douilles Impact longues pour jantes alliage : 17-19-21 mm.
- 1 lot de 5 joncs et 5 goupilles pour douilles impact 1/2" 8 à 14 mm.
- 1 lot de 5 joncs et 5 goupilles pour douilles impact 1/2" 15 à 32 mm.
- 1 rallonge impact 1/2" - 125 mm.
- Plateau vide : E041606.

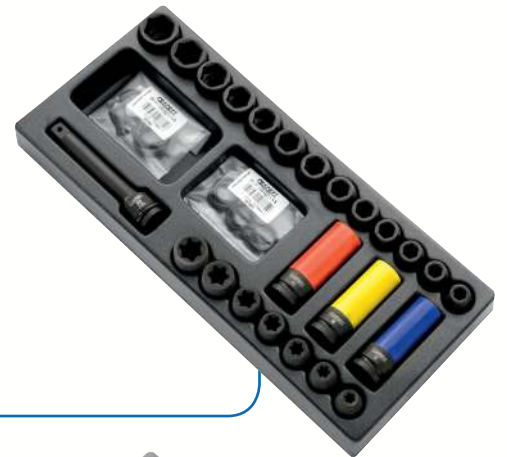

Code	Spécification	Poids kg	Boîte	EAN
E041604	1/2"	3,55	1	3258950416045

MODULE DE DOUILLES IMPACT 1/2" - 17 PIÈCES

- Douilles impact 1/2" : 8-10-11-12-13-14-15-16-17-18-19-21-22-24 mm.
- 2 rallonges impact 1/2" : 50-250 mm.
- 1 cardan impact 1/2".
- Plateau vide : E040602.



Code	Spécification	Poids kg	Boîte	EAN
E040601	1/2"	2,35	1	3258950406015

MODULE DE DOUILLES LONGUES IMPACT 1/2" - 25 PIÈCES

- Douilles longues impact 1/2" 6 pans : 10-11-13-14-16-17-18-19-21-22-24-27-30-32 mm.
- 1 rallonge impact 1/2" : 125 mm.
- Douilles tournevis impact hexagonales 1/2" : 5-6-8-10-12-14-17-19.
- 1 lot de 5 joncs et 5 goupilles pour douilles impact 1/2" de 8 à 14 mm.
- 1 lot de 5 joncs et 5 goupilles pour douilles impact 1/2" de 15 à 32 mm.
- Plateau vide : E041645.



Code	Spécification	Poids kg	Boîte	EAN
E041644	1/2"	5,24	1	3258950416441

JEU DE DOUILLES IMPACT TORX® 1/2" - 7 PIÈCES

- Douilles impact Torx® 1/2" : E10-E12-E14-E16-E18-E20-E24.



Code	Spécification	Poids kg	Boîte	EAN
E041605	1/2"	0,7	1	3258950416052



ACCESSOIRES IMPACT 1/2"

RALLONGES IMPACT 1/2"

- ISO 1174-1
- Spécialement étudiées pour résister aux contraintes des machines à choc.
- Acier au chrome Molybdène.
- Pour votre sécurité, utilisez les rallonges impact avec les bagues et goupilles adaptées.

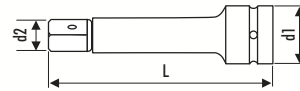

	L mm	d2 mm	Poids g	☒	EAN
E113616	50	16	97	1	3258951136164
E113617	125	16	230	1	3258951136171
E113618	250	16	430	1	3258951136188

DOUILLE IMPACT 1/2" PORTE-EMBOUS 5/16"

- ISO 2725-2 - ISO 1711-1 - ISO 1174-2
- Spécialement étudiée pour résister aux contraintes des machines à choc.
- Acier au chrome Molybdène.
- Pour votre sécurité, utilisez les douilles Impact avec les bagues et goupilles adaptées.

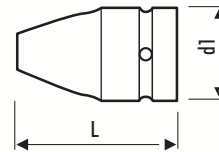

	L mm	Poids g	☒	EAN
E113619	40	90	1	3258951136195

CARDAN IMPACT 1/2"

- ISO 1174-2
- Spécialement étudié pour résister aux contraintes des machines à choc.
- Acier au chrome Molybdène.
- Pour votre sécurité, utilisez les cardans Impact avec les bagues et goupilles adaptées.

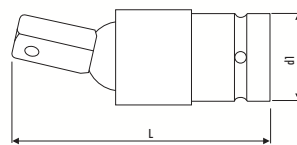

	L mm	Poids g	☒	EAN
E113620	60	170	1	3258951136201

LOT DE 5 JONCS ET 5 BAGUES POUR DOUILLES IMPACT 1/2"

- E117881 pour douilles de 8 à 14 mm.
- E117884 pour douilles de 15 à 32 mm.

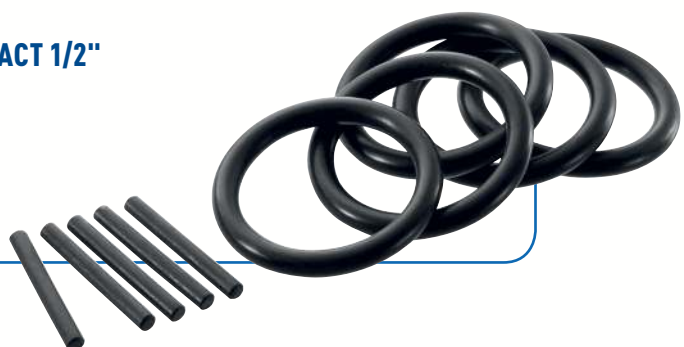

	Poids g	☒	EAN
E117881	5	1	3258951178812
E117884	6	1	3258951178843





DOUILLES IMPACT 1/2"

DOUILLES IMPACT 1/2" - 6 PANS - MÉTRIQUES

→ ISO 2725-2 - ISO 1711-2 - ISO 1174-2

→ Spécialement étudiées pour résister aux contraintes des machines à choc.

→ Acier au chrome Molybdène.

→ Pour votre sécurité, utilisez les douilles Impact avec les bagues et goupilles adaptées.



	A mm	L mm	d1 mm	d2 mm	Poids g	☒	EAN
E113489	8	38	25	15	86	1	3258951134894
E113490	10	38	25	17.5	87	1	3258951134900
E113491	11	38	25	18.7	89	1	3258951134917
E113492	12	38	25	20	89	1	3258951134924
E113493	13	38	25	21.3	88	1	3258951134931
E113494	14	38	25	22.5	88	1	3258951134948
E113495	15	38	30	23.7	136	1	3258951134955
E113496	16	38	30	25	138	1	3258951134962
E113497	17	38	30	26.2	133	1	3258951134979
E113498	18	38	30	27.5	134	1	3258951134986
E113499	19	38	30	28.7	128	1	3258951134993
E113588	21	38	30	30	120	1	3258951135884
E113589	22	38	30	32	160	1	3258951135891
E113592	24	45	30	35	177	1	3258951135921
E113594	27	50	30	38	222	1	3258951135945
E113596	30	50	30	42	240	1	3258951135969
E113597	32	50	30	44	244	1	3258951135976

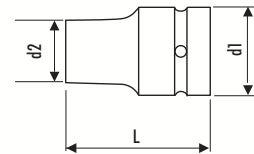

DOUILLES LONGUES IMPACT 1/2" - 6 PANS - MÉTRIQUES

→ ISO 2725-2 - ISO 1711-2 - ISO 1174-2

→ Spécialement étudiées pour résister aux contraintes des machines à choc.

→ Acier au chrome Molybdène.

→ Pour votre sécurité, utilisez les douilles Impact avec les bagues et goupilles adaptées.

	A mm	L mm	d1 mm	d2 mm	Poids g	☒	EAN
E113598	10	78	25	17.5	139	1	3258951135983
E113599	11	78	25	18.7	147	1	3258951135990
E113600	13	78	25	21.3	165	1	3258951136003
E113605	14	78	25	22.5	168	1	3258951136058
E113606	16	78	30	25	238	1	3258951136065
E113607	17	78	30	26.2	238	1	3258951136072
E113608	18	78	30	27.5	252	1	3258951136089
E113609	19	78	30	28.7	252	1	3258951136096
E113610	21	78	30	31	272	1	3258951136102
E113611	22	78	30	32	279	1	3258951136119
E113612	24	78	30	35	325	1	3258951136126
E113613	27	78	30	38	384	1	3258951136133
E113614	30	78	30	42	411	1	3258951136140
E113615	32	78	30	44	427	1	3258951136157

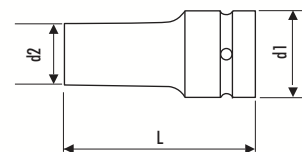



DOUILLES TOURNEVIS HEXAGONALES IMPACT 1/2"

→ ISO 1174-2

- Spécialement étudiées pour résister aux contraintes des machines à choc.
- Acier au chrome Molybdène.
- Douilles tournevis monobloc.
- Pour votre sécurité, utilisez les douilles impact avec les bagues et goupilles adaptées.

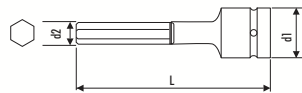

	A mm	L mm	d1 mm	d2 mm	Poids g	☒	EAN
E113623	5	75	25	6	84	1	3258951136232
E113624	6	75	25	7.1	89	1	3258951136249
E113625	8	75	25	9.5	97	1	3258951136256
E113626	10	75	25	11.8	108	1	3258951136263
E113627	12	75	25	14	125	1	3258951136270
E113628	14	75	25	16	143	1	3258951136287
E113629	17	75	25	19.8	178	1	3258951136294
E113630	19	75	25	22.1	203	1	3258951136300



COMPOSITIONS DE DOUILLES IMPACT 3/4"

MODULE MOUSSE IMPACT 3/4" - 11 PIÈCES

- Clé à chocs 3/4".
- Douilles impact 3/4" - métriques : 19-22-24-27-30-32-36-38 mm.
- 1 Lot de 5 joncs et 5 bagues pour douilles impact 3/4" (E113563).
- Rallonge impact 3/4" : 175 mm.
- Plateau vide : E231107.



	☒	Poids g	☒	EAN
E231103	3/4"	8,1	1	3258952311034

ACCESSOIRES IMPACT 3/4"

RALLONGES IMPACT 3/4"

- ISO 1174-2
- Spécialement étudiées pour résister aux contraintes des machines à choc.
- Acier au chrome Molybdène.
- Pour votre sécurité utilisez les rallonges impact avec les bagues et goupilles adaptées.

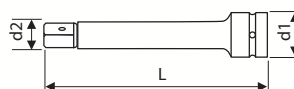

	L mm	d1 mm	d2 mm	Poids g	☒	EAN
E113487	175	44	25	883	1	3258951134870
E113488	250	44	25	1167	1	3258951134887





ACCESSOIRES IMPACT 3/4"

CARDAN IMPACT 3/4"

- ISO 1174-2
- Spécialement étudié pour résister aux contraintes des machines à choc.
- Acier au chrome Molybdène.
- Pour votre sécurité utilisez les cardans impact avec les bagues et goupilles adaptées

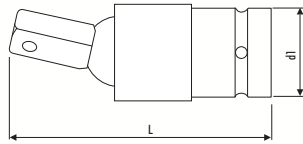

	L mm	d1 mm	Poids g	☒	EAN
E041501	107	25.6	700	1	3258950415017



RÉDUCTEUR IMPACT 3/4" - 1/2"

- ISO 1174-2
- Spécialement étudié pour résister aux contraintes des machines à choc.
- Acier au chrome Molybdène.
- Pour votre sécurité utilisez les adaptateurs Impact avec les bagues et goupilles adaptées.

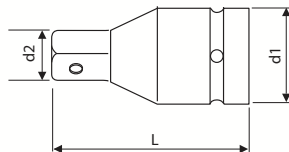

	L mm	d1 mm	d2 mm	Poids g	☒	EAN
E041502	56	44	12.58	350	1	3258950415024



RÉDUCTEUR IMPACT 1" - 3/4"

- ISO 1174-2
- Spécialement étudié pour résister aux contraintes des machines à choc.
- Acier au chrome Molybdène.
- Pour votre sécurité utilisez les adaptateurs Impact avec les bagues et goupilles adaptées.

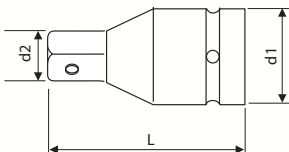

	L mm	d1 mm	d2 mm	Poids g	☒	EAN
E041503	75	54	25	800	1	3258950415031



LOT DE 5 JONCS ET 5 BAGUES POUR DOUILLES IMPACT 3/4"

- Pour douilles 3/4" de 17 à 50 mm.

	Poids g	☒	EAN
E113563	10,6	1	3258951135631





DOUILLES IMPACT 3/4"

DOUILLES IMPACT 3/4" - MÉTRIQUES

- ISO 2725-2 - ISO 1711-2 - ISO 1174-2
- Spécialement étudiées pour résister aux contraintes des machines à choc.
- Acier au chrome Molybdène.
- Pour votre sécurité utilisez les douilles Impact avec les bagues et goupilles adaptées.

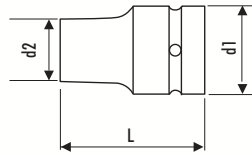

	A mm	L mm	d1 mm	d2 mm	Poids g	☒	EAN
E041101	17	38	30	26.2	367	1	3258950411019
E041102	19	38	30	28.7	367	1	3258950411026
E041103	21	38	30	30	367	1	3258950411033
E041104	22	38	30	32	367	1	3258950411040
E041105	24	45	30	35	400	1	3258950411057
E041106	27	50	30	38	400	1	3258950411064
E113470	30	50	30	42	429	1	3258951134702
E113471	32	50	30	44	475	1	3258951134719
E113472	33	56	44	51	481	1	3258951134726
E113473	34	56	44	52	492	1	3258951134733
E113475	36	56	44	54	523	1	3258951134757
E113476	38	58	44	57	565	1	3258951134764
E113477	41	58	44	60	608	1	3258951134771
E113479	46	63	44	67	770	1	3258951134795

DOUILLES LONGUES IMPACT 3/4" - MÉTRIQUES

- ISO 2725-2 - ISO 1711-2 - ISO 1174-2
- Spécialement étudiées pour résister aux contraintes des machines à choc.
- Acier au chrome Molybdène.
- Pour votre sécurité utilisez les douilles impact avec les bagues et goupilles adaptées.

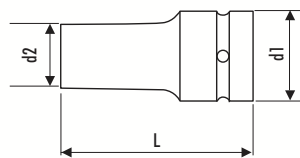

	A mm	L mm	d1 mm	d2 mm	Poids g	☒	EAN
E113480	17	95	44	31	541	1	3258951134801
E113481	19	95	44	33	566	1	3258951134818
E113482	24	95	44	39	634	1	3258951134825
E113483	27	95	44	43	705	1	3258951134832
E113484	30	95	44	47	734	1	3258951134849
E113485	32	95	44	49	829	1	3258951134856
E041301	33	95	44	52	800	1	3258950413013
E113486	36	95	44	54	930	1	3258951134863
E041302	41	95	44	60	1000	1	3258950413020
E041303	46	95	44	67	1200	1	3258950413037





COMPOSITIONS DE DOUILLES IMPACT 1"

JEU DE 4 DOUILLES LONGUES IMPACT 1" SUR RACK

- Douilles longues impact 1" 6 pans – métriques.
- Douilles : 27-32-33-36 mm.
- Livré avec joncs et goupilles de sécurité.
- Livré sur rack métallique [E042406].



E041648	1"	Poids g	1	EAN
		608		3258950416489

JEU DE 8 DOUILLES IMPACT 1" SUR RACK

- Douilles impact 1" 6 pans – métriques.
- Douilles : 27-30-32-33-36-41-46-50 mm.
- Livré avec joncs et goupilles de sécurité.
- Livré sur rack métallique [E042408].



E041647	1"	Poids g	1	EAN
		1350		3258950416472

ACCESSOIRES IMPACT 1"

RALLONGE DOUILLES IMPACT 1"

- ISO 1174-2
- Spécialement étudiées pour résister aux contraintes des machines à choc.
- Acier au chrome Molybdène.
- Pour votre sécurité utilisez les rallonges impact avec les bagues et goupilles adaptées.

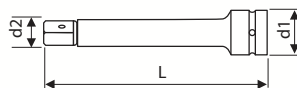

E042402	L mm	d1 mm	d2 mm	Poids g	1	EAN
	200	54	34	1626		3258950424026



LOT DE 5 JONCS ET 5 BAGUES POUR DOUILLES IMPACT 1"

→ Pour douilles 1" de 19 à 70 mm.

E042401	Poids g	☒	EAN
	7	1	3258950424019



DOUILLES IMPACT 1"

DOUILLES IMPACT 1"

→ ISO 2725-2 - ISO 1711-2 - ISO 1174-2

→ Spécialement étudiées pour résister aux contraintes des machines à choc.

→ Acier au chrome Molybdène.

→ Pour votre sécurité utilisez les douilles Impact avec les bagues et goupilles adaptées.

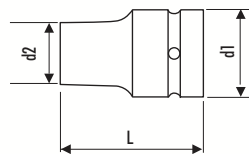

	A mm	L mm	d1 mm	d2 mm	Poids g	☒	EAN
E042204	27	58	50,9	44	500	1	3258950422046
E042207	30	60	50,9	48	540	1	3258950422077
E042208	32	60	50,9	50,9	570	1	3258950422084
E042209	33	62	52	52,9	630	1	3258950422091
E042211	36	62	52	55,9	650	1	3258950422114
E042213	41	62	52	61,5	700	1	3258950422138
E042215	46	64	58	68	980	1	3258950422152
E042216	50	70	58	73	1140	1	3258950422169

DOUILLES IMPACT LONGUES 1"

→ ISO 2725-2 - ISO 1711-2 - ISO 1174-2

→ Spécialement étudiées pour résister aux contraintes des machines à choc.

→ Acier au chrome Molybdène.

→ Pour votre sécurité utilisez les douilles Impact avec les bagues et goupilles adaptées.

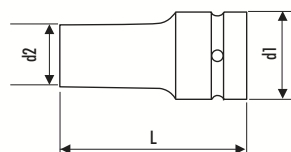

	A mm	L mm	d1 mm	d2 mm	Poids g	☒	EAN
E042304	27	90	50,9	44	740	1	3258950423043
E042307	32	90	50,9	50,9	900	1	3258950423074
E042308	33	90	52	52,9	940	1	3258950423081
E042310	36	90	52	55,9	1000	1	3258950423104

PINCES





Jeux de pinces mécanicien

P.160



Pincres multiprises

P.162



Pincres universelles

P.162



Pincres coupantes

P.163



Pincres de préhension

P.165



Pincres circlips®

P.166



Tenailles

P.168



Pincres-étaux

P.168



PINCES 1000 VOLTS ET PINCES ÉLECTRONIQUES

Voir section Électricité - Électronique p 212.

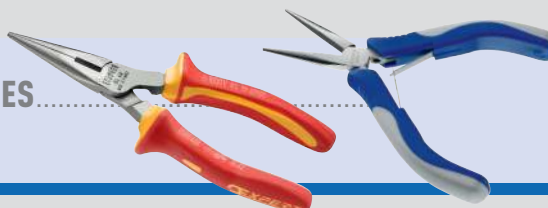



JEUX DE PINCES MÉCANICIEN

JEU DE 4 PINCES MÉCANIQUES POUR MÉCANICIEN

- Pince universelle 180 mm : E080504.
- Pince coupante diagonale 160 mm : E080205.
- Pince à becs 1/2 ronds droits 200 mm : E080408.
- Pinces multiprises 240 mm : E184690.
- Fabriqué en France.



	Quantité	Poids g		EAN
E080817	4	975	1	3258950808178

JEU DE 4 PINCES MÉCANIQUES POUR MÉCANICIEN

- Pince universelle 180 mm : E080504.
- Pince coupante diagonale 160 mm : E080205.
- Pince à becs 1/2 ronds droits 200 mm : E080408.
- Pinces multiprises 240 mm : E084648.
- Fabriqué en France.



	Quantité	Poids g		EAN
E080818	4	985	1	3258950808185

JEU DE 2 PINCES MÉCANIQUES POUR MÉCANICIEN

- Pince coupante diagonale 160 mm : E080205.
- Pinces multiprise 240 mm : E184690.
- Fabriqué en France.



	Quantité	Poids g		EAN
E080815	2	558	1	3258950808154

JEU DE 3 PINCES MÉCANIQUES POUR MÉCANICIEN

- Pince universelle 180 mm : E080504.
- Pince coupante diagonale 160 mm : E080205.
- Pince à becs 1/2 ronds droits 200 mm : E080408.
- Fabriqué en France.



	Quantité	Poids g		EAN
E080816	3	730	1	3258950808161



JEU DE 7 PINCES ET TOURNEVIS

- Pince universelle 180 mm : E080504.
- Pince coupante diagonale 160 mm : E080205.
- Tournevis plat : 3,5 X 75 E164983.
- Tournevis plat : 4 X 100 E165017.
- Tournevis plat : 5.5 X 125 E165476.
- Tournevis Phillips : PH 1 X 100 E165207.
- Tournevis Phillips : PH 2 X 125 E165209.
- Fabriqué en France.

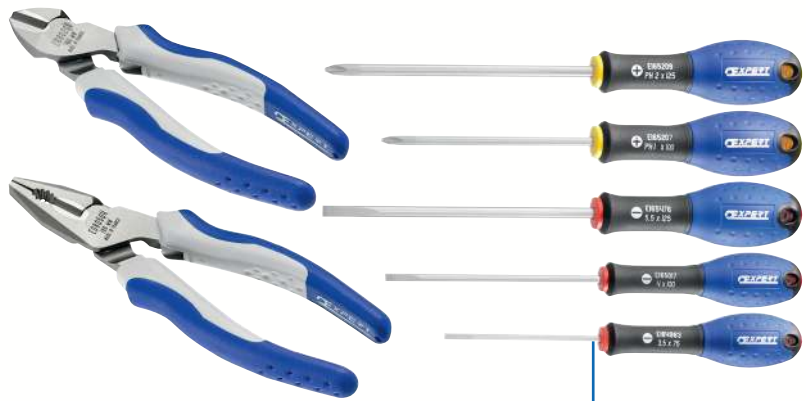

E080819	Quantité	Poids g	📦	EAN
E080819	7	2500	1	3258950808192



MODULES DE PINCES MÉCANICIEN

MODULE DE 4 PINCES MÉCANICIEN

- 1 pince coupante diagonale 160 mm : E080205.
- 1 pince universelle 180 mm : E080504.
- 1 pince à dénuder 170 mm : E050106.
- 1 pince demi-ronde à becs droits 200 mm : E080408.
- Plateau thermoformé vide : E010537.



E080821	Quantité	Poids g	📦	EAN
E080821	4	1246	1	3258950808215

MODULE DE 2 PINCES MULTIPRISE / ÉTAU

- 1 pince multiprise : E184690.
- 1 pince étau : E080701.
- Plateau thermoformé vide : E010504.



E080801	Quantité	Poids g	📦	EAN
E080801	2	1370	1	3258950808017

MODULE DE 2 PINCES MULTIPRISE ENTREPASSÉE / ÉTAU

- 1 pince multiprise entrepassée : E084648.
- 1 pince étau mono réglable becs courts : E084809.
- Plateau thermoformé vide : E010504.



E194944	Quantité	Poids g	📦	EAN
E194944	2	1264	1	3258951949443



PINCES MULTIPRISES

PINCES MULTIPRISES ENTREPASSÉES À VERROUILLAGE

- ISO 8976
- Multi-positions.
- Bouton pushlock (breveté).
- Poignée ergonomique bi-matière.
- Finition : chrome noir.
- 17 positions.

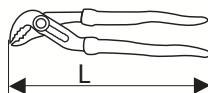

	L mm	Profondeur de mâchoire mm	Poids g		EAN
E084648	260	31.6	254	5	3258950846484
E084649	311	69.5	304	5	3258950846491

PINCE MULTIPRISE SUPERPOSÉE

- ISO 8976
- Branches spatulées.
- Gaines en PVC bleu.
- Finition : grenailée vernie.

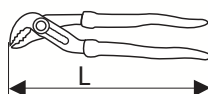

	L mm	Profondeur de mâchoire mm	Poids g		EAN
E184690	240	32.5	310	10	3258951846902

PINCES UNIVERSELLES

PINCES UNIVERSELLES

- DIN ISO 5746
- Conçues pour répondre à toutes les applications de préhension et de coupe. Taillants conçus pour une coupe nette sur tous types de fil (fils mous, mi-durs, durs).
- Poignée ergonomique pour un meilleur confort lors d'utilisations longues et répétitives.
- Corde à piano E080503 : Maxi 1,6 mm 220 kg/mm².
- Corde à piano E080504 : Maxi 1,8 mm 215 kg/mm².
- Corde à piano E080505 : Maxi 2 mm 210 kg/mm².
- Fabriqué en France.

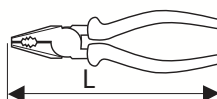

	L mm	Poids g		EAN
E080503	160	195	1	3258950805030
E080504	180	225	1	3258950805047
E080505	200	300	1	3258950805054



PINGES COUPANTES

PINGES COUPANTES ÉLECTRICIEN

- **DIN ISO 5749**
- Modèle conçu spécialement pour l'électricien, offrant une parfaite accessibilité dans les espaces confinés.
- Taillants conçus pour garantir les meilleures performances sur les fils mous (cuivre) et mi-durs.
- Poignée ergonomique pour un meilleur confort lors de coupes très répétitives.
- Corde à piano E080208 : Maxi 1,4 mm 160 kg/mm².
- Corde à piano E080209 : Maxi 1,6 mm 160 kg/mm².
- Corde à piano E080210 : Maxi 1,8 mm 160 kg/mm².
- Fabriqué en France.

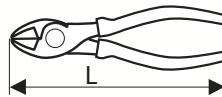

	L mm	Poids g	☒	EAN
E080208	140	155	1	3258950802084
E080209	160	190	1	3258950802091
E080210	180	250	1	3258950802107

PINGES COUPANTES

- **DIN ISO 5749**
- Conçues pour offrir une parfaite polyvalence indépendamment de l'effort de coupe.
- Taillants conçus pour garantir les meilleures performances sur les fils mous (cuivre), mi-durs et durs (acier inoxydable, ressort).
- Poignée ergonomique pour un meilleur confort lors de coupes très répétitives.
- Corde à piano E080205 : Maxi 1,6 mm 220 kg/mm².
- Corde à piano E080206 : Maxi 1,8 mm 215 kg/mm².
- Corde à piano E080207 : Maxi 2 mm 210 kg/mm².
- Fabriqué en France.

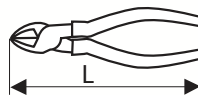

	L mm	Poids g	☒	EAN
E080205	160	200	1	3258950802053
E080206	180	260	1	3258950802060
E080207	200	320	1	3258950802077

PINCE COUPANTE DEVANT - 160 MM

- **DIN ISO 5748**
- Taillants conçus pour assurer une coupe nette sur fils durs et mi durs.
- Effort de coupe minimal grâce à un bras-levier plus long.
- Poignée ergonomique pour un meilleur confort lors de coupes très répétitives.
- Cordes à piano Maxi 1,6 mm 220 kg/mm².
- Fabriquée en France.

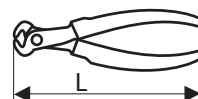

	L mm	Poids g	☒	EAN
E080211	160	200	1	3258950802114





PINCES COUPANTES

PINCES COUPANTES DIAGONALES

- Corps en acier au Chrome vanadium.
- Mors en chrome poli pour une coupe précise et efficace.
- Gains en PVC bleu.

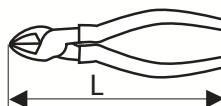

	L mm	Poids g		EAN
E020308	150	130	5	3258950203089
E020309	175	215	5	3258950203096

PINCE COUPANTE DIAGONALE OBLIQUE

- Corps en acier au Chrome vanadium.
- Mors en chrome poli pour une coupe précise et efficace.
- Gains en PVC bleu.

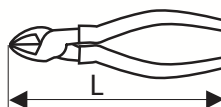

	L mm	Poids g		EAN
E020310	150	127	2	3258950203102

PINCES DE PRÉHENSION

PINCE DEMI-RONDE - BECS COUDÉS À 40°

- ISO 5745
- Becs fins pour assurer une accessibilité optimale lors d'utilisation dans un environnement confiné (armoires électriques).
- Becs finement striés équipés d'un coupe fil latéral.
- Poignée ergonomique pour un meilleur confort lors d'utilisations longues et répétitives.

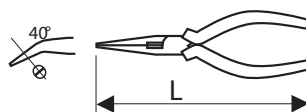

	L mm	Poids g		EAN
E080409	160	177	1	3258950804095
E080410	200	192	1	3258950804101



PINGES DE PRÉHENSION

PINCE PLATE - BECS DROITS - 160 MM

- DIN ISO 5745
- Becs légèrement striés offrant une parfaite préhension.
- Poignée ergonomique pour un meilleur confort.
- Fabriqué en France.



	L mm	Poids g		EAN
E080411	160	140	1	3258950804118

PINCE - BECS ROUNDS - 170 MM

- DIN ISO 5745
- Idéale pour confectionner des boucles, coudes ou anneaux.
- Poignée ergonomique pour un meilleur confort.
- Fabriqué en France.



	L mm	Poids g		EAN
E080412	170	135	1	3258950804125

PINGES - BECS LONGS

- DIN ISO 5745
- Becs fins offrant une parfaite accessibilité dans les espaces confinés (armoires électriques).
- Becs finement striés avec coupe-fil latéral
- Maxi 1,6 mm 160 kg/mm².
- Poignée ergonomique pour un meilleur confort lors d'utilisations longues et répétitives.
- Fabriqué en France.



	L mm	Poids g		EAN
E080407	160	177	1	3258950804071
E080408	200	192	1	3258950804088





MODULE DE PINCES CIRCLIPS®

MODULE 4 PINCES CIRCLIPS®

- 1 pince fermante droite : E117914.
- 1 pince fermante becs à 90° : E117922.
- 1 pince ouvrante droite : E117910.
- 1 pince ouvrante becs a 90° : E117918.
- Plateau thermoformé vide : E010503.



	Quantité	Poids g		EAN
E194943	4	1052	1	3258951949436

PINCES CIRCLIPS®

JEU DE 4 PINCES CIRCLIPS®

- 1 pince fermante droite : E117914.
- 1 pince fermante becs à 90° : E117922.
- 1 pince ouvrante droite : E117910.
- 1 pince ouvrante becs 90° : E117918.



	Poids g maxi		EAN
E080820	785	1	3258950808208

PINCES CIRCLIPS® - FERMANTES BECS DROITS

- DIN 5256 - NF E 73-130
- Becs usinés permettant un parfait positionnement du Circlips®.
- Gaine PVC Bleu.

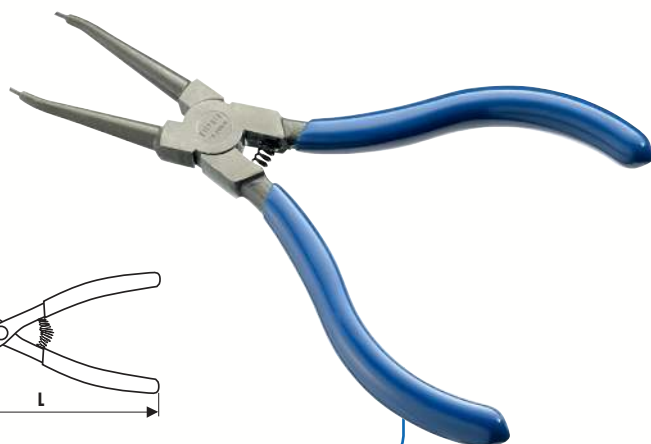
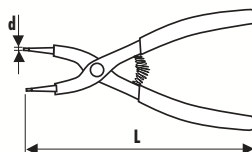

	d mm»	L mm	Circlips mini-maxi mm	Poids g		EAN
E117912	0.9	140	3-10	95	10	3258951179123
E117913	1.3	145	10-25	100	10	3258951179130
E117914	1.8	185	19-60	140	10	3258951179147
E117915	2	215	40-100	330	10	3258951179154



PINCES CIRCLIPS® - FERMANTES BECS À 90°

→ DIN 5256 - NF E 73-130

→ Becs usinés permettant un parfait positionnement du Circlips®.

→ Gaine PVC Bleu.

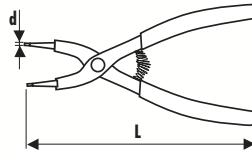
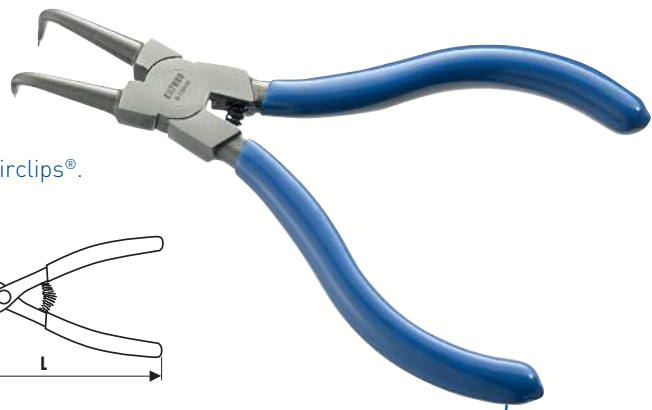

	d mm»	L mm	Circlips mini-maxi mm	Poids g	☒	EAN
E117920	0.9	130	3-10	95	10	3258951179208
E117921	1.3	130	10-25	100	10	3258951179215
E117922	1.8	170	19-60	150	10	3258951179222
E117923	2	275	40-100	330	10	3258951179239

PINCES CIRCLIPS® - OUVRANTES BECS DROITS

→ DIN 5254 - NF E 73-130

→ Becs usinés permettant un parfait positionnement du Circlips®.

→ Gaine PVC Bleu.

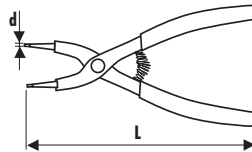
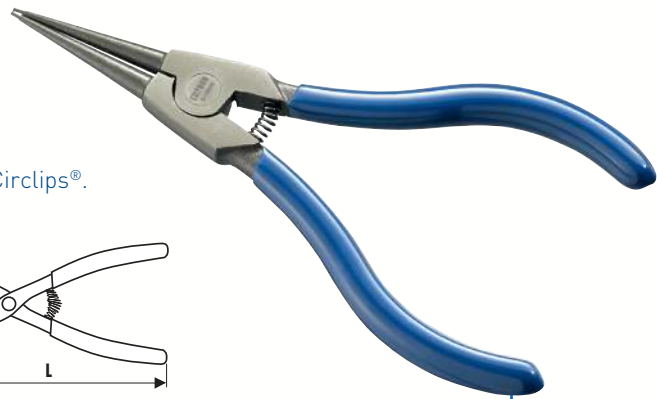

	d mm»	L mm	Circlips mini-maxi mm	Poids g	☒	EAN
E117908	0.9	150	3-10	95	10	3258951179086
E117909	1.3	150	10-25	100	10	3258951179093
E117910	1.8	180	19-60	160	10	3258951179109
E117911	2	180	40-100	330	10	3258951179116

PINCES CIRCLIPS® - OUVRANTES BECS COUDÉS À 90°

→ DIN 5254 - NF E 73-130

→ Becs usinés permettant un parfait positionnement du Circlips®.

→ Gaine PVC Bleu.

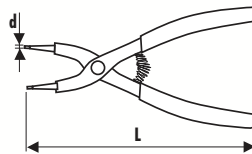

	d mm»	L mm	Circlips mini-maxi mm	Poids g	☒	EAN
E117916	0.9	140	3-10	95	10	3258951179161
E117917	1.3	140	10-25	105	10	3258951179178
E117918	1.8	170	19-60	150	10	3258951179185
E117919	2	200	40-100	330	10	3258951179192





TENAILLES

TENAILLES RUSSES

- ISO 9242
- Branche rigide semi arrondie pour une manipulation facilitée.
- Taillants traités "HF" pour une durée de vie et des performances de coupe accrues.
- Capacité de coupe maxi : 4,5 mm pour fil doux et fil dur 160 kg/mm².
- Finition brunie tête polie.

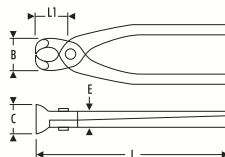

	B mm	C mm	L mm	L1 mm	Poids g	☒	EAN
E184179	28	12	200	10	265	10	3258951841792
E184302	31	13	220	10.5	325	10	3258951843024
E184181	35	14	250	12	425	10	3258951841815
E184182	35	14	280	12	495	10	3258951841822

PINCES-ÉTAUX

PINCES-ÉTAUX MONO RÉGLAGE BECS COURTS

- Corps chromé anticorrosion.
- Mors usinés avec précision.
- Denture sur toute la profondeur.
- Puissance de serrage réglable par vis.
- Levier de déblocage.

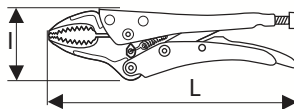

	L mm	l mm	Profondeur de mâchoire mm	Poids g	☒	EAN
E084807	140	47	23	205	5	3258950848075
E084808	190	60	34	415	5	3258950848082
E084809	250	75	50	659	5	3258950848099

PINCES-ÉTAUX MONO RÉGLAGE BECS LONGS

- Pincettes à bec long qui permet un meilleur accès et est idéal pour des travaux plus délicats.
- Corps chromé anticorrosion.
- Mors usinés avec précision. Denture sur toute la profondeur de la mâchoire.
- Puissance de serrage réglable par vis.
- Levier de déblocage.

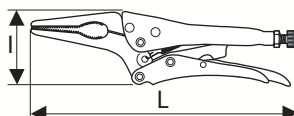

	L mm	l mm	Profondeur de mâchoire mm	Poids g	☒	EAN
E084812	170	47	51	227	5	3258950848129
E084813	235	56	66	450	5	3258950848136



PINCES-ÉTAUX LONGUE PORTÉE

- Pincés-étaux en "C".
- Mâchoires spéciales en acier forgé pour garantir un parfait maintien des profilés, fer en U et cornières.
- Corps chromé anticorrosion.
- Mors usinés avec précision.
- Puissance de serrage réglable par vis.
- Levier de déblocage.

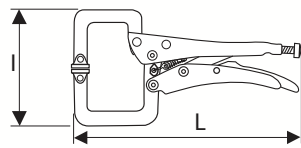

E084816



E084815

	L mm	l mm	Profondeur de mâchoire mm	Hauteur de machoir mm	Poids g	☒	EAN
E084815	170	88	37	58	265	5	3258950848150
E084816	290	150	65	100	890	5	3258950848167

PINCE-ÉTAU GRANDE CAPACITÉ

- Pince-étau idéale pour bénéficier d'une capacité de prise importante sur rond / carré et cornière.
- Crémaillère à bouton 4 positions.
- Corps chromé.
- Finition pincés phosphate.
- Mors usinés avec précision.
- Becs de 17 mm de largeur.

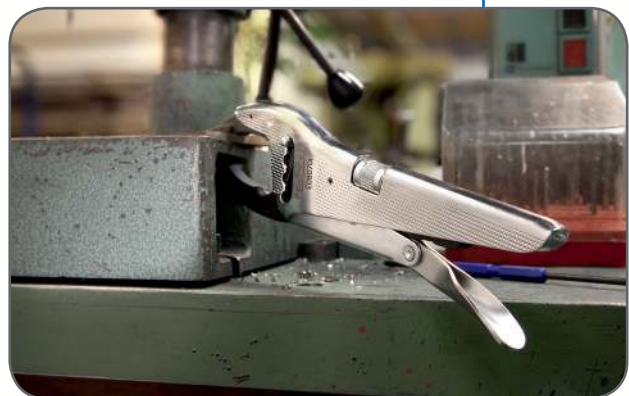
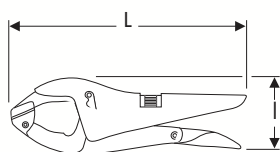

	L mm	l mm	Poids g	☒	EAN
E080701	250	63	620	1	3258950807010



MESURAGE - TRAÇAGE

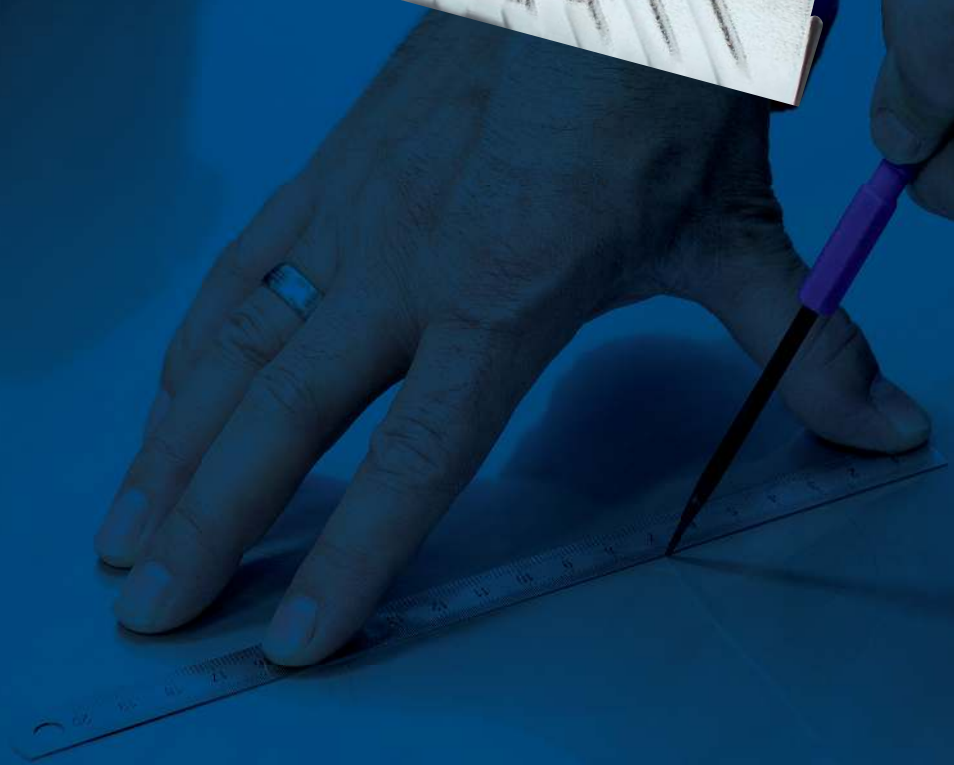



Modules

P.172



Niveaux

P.173



Mètres à ruban

P.173



Pied à coulisse

P.174



Réglet

P.174



Pointe carrée

P.174



Pointes à tracer

P.175





MODULES

MODULE TÔLERIE

- 1 pince à riveter 270 mm : E169804.
- 1 pied à coulisse mécanique 1/20 mm : E140601.
- 1 réglét 200 mm : E140801.
- 1 pointe automatique Ø 7 mm : E150504.
- 1 pointe à tracer acier 190 mm : E003601.
- 1 cisaille aviation coupe droite : E214563.
- Plateau thermoformé vide : E142402.



	Quantité	Poids g		EAN
E142401	6	1513	1	3258951424018

MODULE TÔLERIE 2/3

- 1 pince à riveter 270 mm : E169804.
- 1 pointeaux 4 mm : E150502.
- 1 pointe à tracer acier 190 mm : E003601.
- 1 réglét 200 mm : E140801.
- 1 cisaille aviation coupe droite : E214563.
- 1 scie à métaux - poignée revolver: E115122.
- 1 mètre à ruban bi-matière : E140103.
- 1 cutter 18 mm : E020302.
- 1 pied à coulisse mécanique 1/20 mm : E140601.
- Plateau thermoformé vide : E010519.



	Quantité	Poids g		EAN
E090302	9	2305	1	3258950903026



NIVEAUX

NIVEAUX MAGNÉTIQUES

- DIN 877
- Corps en alliage léger.
- 2 aimants.



	Dimensions	Poids g	☒	EAN
E142301	300 x 50 x 20 mm	286	1	3258951423011
E142302	450 x 50 x 20 mm	364	1	3258951423028
E142303	600 x 50 x 20 mm	442	1	3258951423035

MÈTRES À RUBAN

MÈTRES À RUBAN

- Précision de classe II.
- Boîtier ergonomique en chrome.
- Lame durable avec revêtement en nylon.
- Verrouillage de la lame efficace.
- Agrafe de ceinture en acier inoxydable.

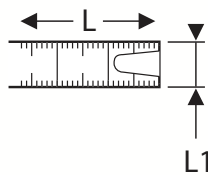

	L mm	L1 mm	Poids g	☒	EAN
E140105	3	13	90	1	3258951401057
E140406	5	19	200	1	3258951401064





PIED À COULISSE

PIED À COULISSE UNIVERSEL 1/20^{ÈME} - 0,05 MM

- DIN 862
- Précision 1/20^{ème} - 0,05 mm.
- Capacité de mesure : 150 mm.
- Mesure d'intérieur, d'extérieur et de profondeur.
- Livré en housse de protection avec certificat de conformité.

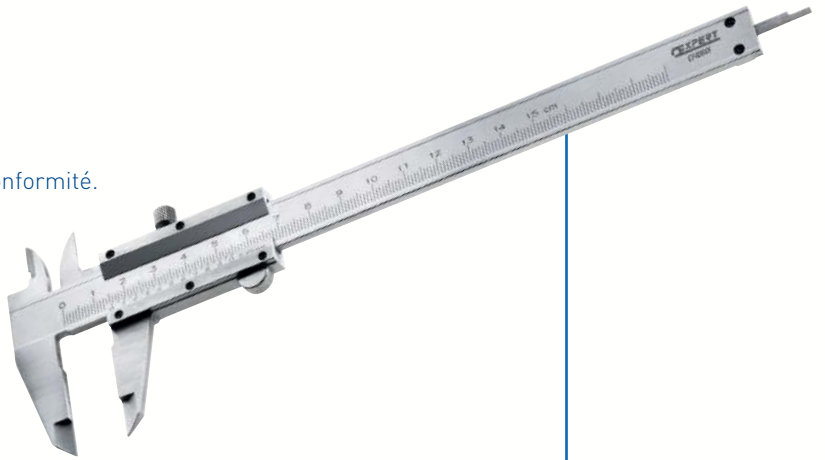

	L mm	Poids g		EAN
E140601	235	185	10	3258951406014

RÉGLET

RÉGLET FLEXIBLE

- Gravé sur les deux faces.
- mm et 1/2mm sur chaque face.

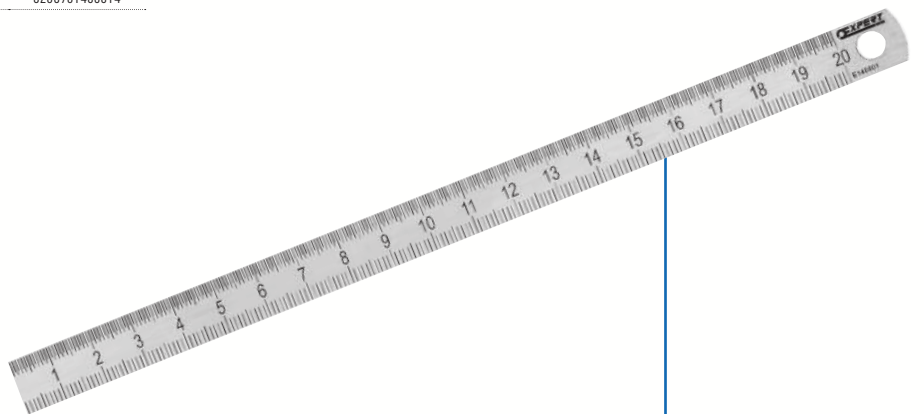

	L mm	Poids g		EAN
E140801	217	12	10	3258951408018

POINTE CARRÉE

POINTE CARRÉE

- Poignée soft grip antidérapante.
- Lame ronde chromée.
- Pointe affûtée.



	L1 mm	L2 mm	d mm	Poids g		EAN
E161114	180	75	32	60	10	3258951611142



POINTES À TRACER

POINTE À TRACER CARBURE - TYPE CRAYON - 150 MM

- Pointe à tracer carbure.
- Corps hexagonal muni d'une agrafe.
- Pointe réaffûtable.
- Diamètre 2,5 mm.



	L mm	Poids g	📦	EAN
E140902	150	35	10	3258951409022

POINTE À TRACER ACIER - 190 MM

- Corps plastique.
- Diamètre pointe : 0,4 mm.
- Diamètre corps : 8 mm.



	L mm	Poids g	📦	EAN
E003601	190	20	10	3258950036014



FRAPPE





Modules outils de frappe

P.178



Marteaux

P.178



Masses

P.180



Maillets

P.181



Massettes

P.181



Outils de frappe

P.182





MODULES OUTILS DE FRAPPE

MODULES OUTILS DE FRAPPE PLATEAU THERMOFORMÉ

- Plateau thermoformé.
- 1 marteau.
- 1 massette de 32 mm.
- 3 chasse-goupilles de 4, 6 et 8 mm.
- 1 burin à profil constant de 24 mm.
- 1 pointeau de 6 mm.
- E150801 : Marteau rivoir E154668 - plateau vide : E010501.
- E150802 : Marteau DIN E150103 - plateau vide : E010506.
- E150803 : Marteau tête boule E150107 - plateau vide : E010507.



	Quantité	Poids g		EAN
E150801	1	1945	1	3258951508015
E150802	1	1911	1	3258951508022
E150803	1	1610	1	3258951508039

MARTEAUX

MARTEAUX RIVOIRS

- ISO 15601
- Tête duresité 50-58 HRc.
- Liaison tête-manche par coinçage.
- Manche Hickory.
- Tête bombée.

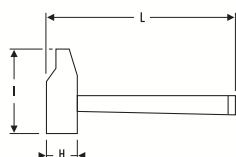

	H mm	L mm	l mm	Poids g		EAN
E154665	25	284	78.5	245	1	3258951546659
E154667	30	304	91.5	530	1	3258951546673
E154668	32	306	98	650	1	3258951546680
E154669	35	309	104	800	1	3258951546697
E154670	40	325	108.5	1020	1	3258951546703
E154672	45	355	126	1600	1	3258951546727
E154673	50	365	135.5	1900	1	3258951546734
E154674	55	370	141	2400	1	3258951546741



MARTEAUX DIN

- DIN 1041, ISO 15601
- Tête duresité 50-58 HRc.
- Manche frêne.
- Coinchage conique.

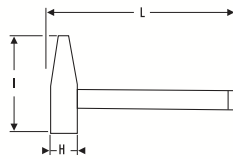

	H mm	L mm	L mm	Poids g	☒	EAN
E150101	19	280	95	300	1	3258951501016
E150102	23	300	105	410	1	3258951501023
E150103	27	320	120	625	1	3258951501030
E150104	33	350	130	960	1	3258951501047
E150105	36	360	135	1180	1	3258951501054

MARTEAUX TÊTE BOULE

- ASME B107.53
- Tête duresité 50-56 HRc.
- Manche Hickory.
- Coinchage par coin métal et coin bois.

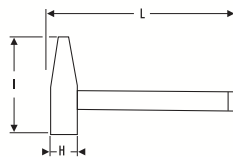

	d mm"	L mm	L mm	Poids g	☒	EAN
E150106	19	275	64	200	1	3258951501061
E150107	23.5	300	82.5	355	1	3258951501078
E150108	30.5	350	101.7	590	1	3258951501085
E150109	35.5	396	120	890	1	3258951501092
E150110	38.5	400	124.5	1110	1	3258951501108





MARTEAUX

MARTEAU CUIVRE ET CUIR

- Manche bois.
- Têtes en cuivre et cuir roulé.

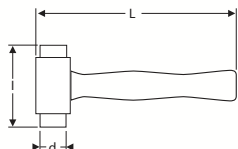

	d mm"	L mm	l mm	Poids g	☒	EAN
E151002	32	270	95	680	1	3258951510025
E151003	38	305	105	1135	1	3258951510032
E151004	44	305	120	1590	1	3258951510049

MASSES

MASSES À ANGLE ABATTU

- ISO 15601
- Tête duresité 50-58 HRc.
- Manche frêne.
- Coinçage conique.

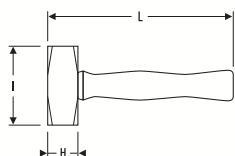

	H mm	L mm	l mm	Poids g	☒	EAN
E150111	40	260	95	1000	1	3258951501115
E150112	43	260	100	1250	1	3258951501122
E150113	45	280	110	1500	1	3258951501139
E150114	50	300	120	2000	1	3258951501146



MAILLETS

MAILLETS SANS REBOND

- Matière : caoutchouc synthétique SBR (styrène-butadiène rubber).
- Anti-rebond grâce à des billes d'acier.
- Anti-vibration.
- Dureté tête shore A80-90.
- Indémanchable : monobloc.

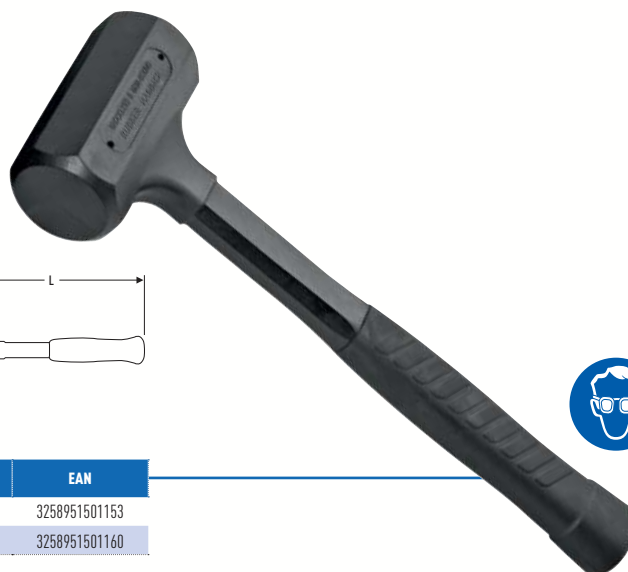
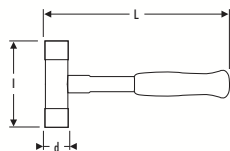

	d mm"	L mm	l mm	Poids g		EAN
E150115	37,4	286	91,5	500	1	3258951501153
E150116	54	370	131,5	1370	1	3258951501160

MASSETTES

MASSETTES A EMBOUTS INTERCHANGEABLES

- Tête en alliage d'acier zingué.
- Manche bois.
- 2 embouts en nylon.

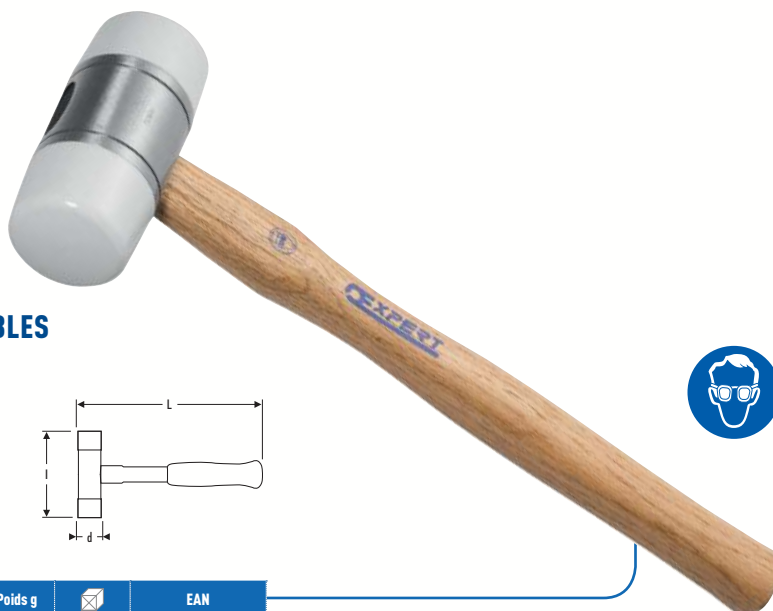
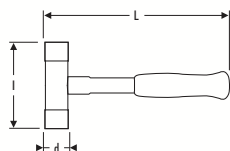

	d mm"	L mm	l mm	Poids g		EAN
E150301	27	270	90	200	1	3258951503010
E150302	32	290	100	290	1	3258951503027
E150303	40	330	110	600	1	3258951503034
E150304	50	350	115	950	1	3258951503041

EMBOUITS INTERCHANGEABLES NYLON

- Embouts nylon de dureté shore D66-85.
- Facilement remplaçables.



	d mm"	Poids g		EAN
E150305	27	20	1	3258951503058
E150306	32	33	1	3258951503065
E150307	40	48	1	3258951503072
E150308	50	60	1	3258951503089





OUTILS DE FRAPPE

JEU DE 6 CHASSE-GOUPILLES

→ DIN 6450

→ 6 chasse-goupilles de 2-3-4-5-6-8 mm.



EAN	Quantité	Poids g	📦	EAN
E418226	6	970	1	3258954182267

CHASSE-GOUPILLES

→ Dureté 48-56 HRc pour les diamètres 2 à 4 mm, et 50-58 HRc pour les diamètres 5 à 8 mm.

→ Monobloc pour plus de robustesse et de durabilité.

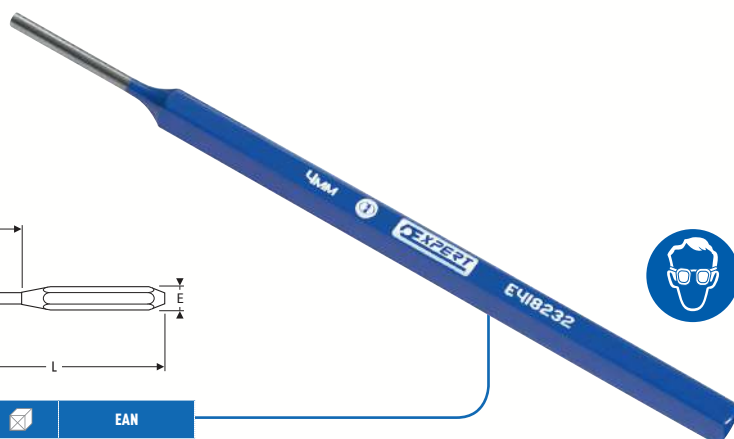
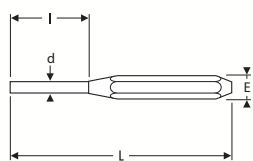

	d mm"	E mm	L mm	l mm	Poids g	📦	EAN
E418230	2	6.3	152	25	35	1	3258954182304
E418231	3	7.9	152	35	52	1	3258954182311
E418232	4	7.9	152	40	55	1	3258954182328
E418233	5	7.9	152	45	55	1	3258954182335
E418234	6	9.5	152	50	75	1	3258954182342
E418235	8	9.5	152	50	85	1	3258954182359

POINTEAUX

→ Dureté 34-44 HRc pour la zone de frappe et 50-58 HRc pour la pointe.

→ Monobloc pour plus de robustesse et de durabilité.

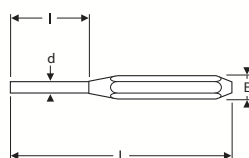

	d mm"	E mm	L mm	l mm	Poids g	📦	EAN
E150501	2.5	9.5	102	25.4	51	1	3258951505014
E150502	4	9.5	102	25.4	53	1	3258951505021
E418227	6	9.5	102	25.4	55	1	3258954182274
E418228	8	11.1	114	25.4	86	1	3258954182281
E418236	10	11.1	127	25.4	100	1	3258954182366



POINTEAUX AUTOMATIQUES

- Dureté 56-61 HRC pour la pointe.
- Charge de déclenchement E150503 : 6 à 12,5 kg - E150504 : 12,2 à 18,5 kg.
- Corps en bronze.

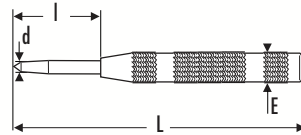

	d mm"	E mm	L mm	l mm	Poids g	📦	EAN
E150503	4	14	130	27	72	1	3258951505038
E150504	7	17	151	26.7	133	1	3258951505045



BURIN EXTRA PLAT 26 MM

- DIN 7255
- Traité pour 54-58 HRC.

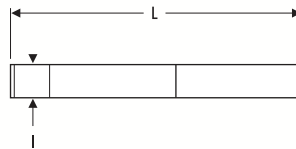

	L mm	l mm	Poids g	📦	EAN
E150701	235	26	250	1	3258951507018



BURINS À PROFIL CONSTANT

- DIN 7255
- Traité pour 54-58 HRC.

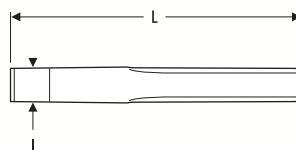

	L mm	l mm	Poids g	📦	EAN
E150702	150	21	195	1	3258951507025
E150703	200	24	350	1	3258951507032
E150704	250	27	510	1	3258951507049



COUPE





Scies métal

P.186



Limes

P.187



Coupe-boulons

P.189



Cisailles

P.190



Cutters

P.192



Couteau

P.193



Ciseaux

P.193



Coupe-tout

P.193





SCIES MÉTAL

SCIE À MÉTAUX - POIGNÉE REVOLVER + 1 LAME

- Scie poignée revolver - Tension jusqu'à 100 Kg
- Capacité de coupe de 100 mm.
- Pré-tension de la lame grâce à un système de levier ;
Réglage et mise sous tension aisés.
- Livrée avec une lame bi-métal.
- Archet en acier chromé - Partie avant et arrière revêtement peinture.
- Lame 300 mm.

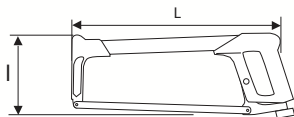

	L mm	l mm	Poids g		EAN
E115122	376	131	590	1	3258951151228

SCIE AJUSTEUR - MANCHE BOIS + 1 LAME

- Archet en métal revêtement époxy - Tension de
lame jusqu'à 80 kg - Capacité de coupe de 100 mm.
- Tension de lame à l'avant de l'archet.
- Livrée avec une lame HSS.
- Poignée bois.
- Lame 300 mm.

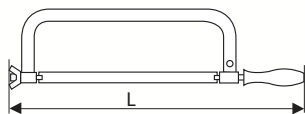

	L mm	Poids g		EAN
E115123	455	550	1	3258951151235

LAME BI-MÉTAL - 300 MM

- Lame de rechange pour scies à métaux E115122 et E115123
- Conditionnées par 10 en tube plastique.
- Commande par multiples de 10.
Exemple : 20 x E115126 = 20 lames.



	L mm	Poids g		EAN
E115126	300	160	10	3258951151266

MINI SCIE + 1 LAME

- Monture de l'archet en aluminium laquée.
- Légère et bonne prise en main - idéale pour les
petits travaux sur matières plastiques et métal.
- Livrée avec une lame en acier carbone.
- Poignée en plastique.
- Lame 155 mm.

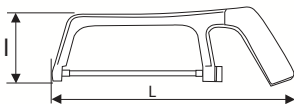

	L mm	l mm	Poids g		EAN
E020101	257	94	140	1	3258950201016



LAME - 150 MM

- lame de rechange pour mini scie E020101.
- Conditionnées par 10 en tube plastique.
- Commande par multiples de 10.
Exemple : 20 x E020103 = 20 lames.



E020103	L mm	Poids g	📦	EAN
E020103	150	120	10	3258950201030

LIMES

JEU DE 5 LIMES MI-DOUCES

- 1 lime plate mi-douce 200 mm : E020602.
- 1 lime demi-ronde mi-douce 200 mm : E020604.
- 1 lime ronde mi-douce 200 mm : E020607.
- 1 lime carré mi-douce 200 mm : E020609.



E020613	Quantité	Poids g	📦	EAN
E020613	5	826	1	3258950206134

JEU DE 3 LIMES MI-DOUCES

- 1 lime plate mi-douce 200 mm : E020602.
- 1 lime demi-ronde mi-douce 200 mm : E020604.
- 1 lime ronde mi-douce 200 mm : E020607.



E020612	Quantité	Poids g	📦	EAN
E020612	3	450	1	3258950206127

MODULE DE 4 LIMES

- 1 lime plate bâtarde 200 mm : E020603.
- 1 lime demi-ronde mi-douce 200 mm : E020604.
- 1 lime ronde mi-douce 200 mm : E020607.
- 1 lime carré mi-douce 200 mm : E020609.
- Plateau vide : E010514.



E020611	Quantité	Poids g	📦	EAN
E020611	4	758	1	3258950206110





LIMES

LIMES PLATES

- Poignée en plastique.
- Longueur de lame: 200 mm.
- A = mi-douce. B = bâtarde.



	Type	Poids g	📦	EAN
E020602	A	180	5	3258950206028
E020603	B	180	5	3258950206035

LIMES DEMI-RONDES

- Poignée en plastique.
- Longueur de lame: 200 mm.
- A = mi-douce. B = bâtarde.



	Type	Poids g	📦	EAN
E020604	A	164	5	3258950206042
E020605	B	164	5	3258950206059

LIMES RONDES

- Poignée en plastique.
- Longueur de lame: 200 mm.
- A = mi-douce. B = bâtarde.



	Type	Poids g	📦	EAN
E020607	A	106	5	3258950206073
E020608	B	106	5	3258950206080

LIME CARRÉE MI-DOUCE

- Poignée en plastique.
- Longueur de lame: 200 mm.
- Lime mi-douce.



	Type	Poids g	📦	EAN
E020609	A	110	5	3258950206097



LIME TRIANGULAIRE MI-DOUCE

- Poignée en plastique.
- Longueur de lame: 200 mm.
- Lime mi-douce.



	Type	Poids g	📦	EAN
E020610	A	200	5	3258950206103

COUPE-BOULONS

COUPE-BOULONS BRAS TUBULAIRES

- Mors forgés au chrome molybdène.
- Capacité de coupe acier jusqu'à 160 kg/mm².
- Bras tubulaires.



	L mm	d mm -100kg/mm	d mm -130kg/mm	d mm -160kg/mm	Poids g	📦	EAN
E195561	300	6	4	3	720	1	3258951955611
E117750	350	8	6	5	1220	1	3258951177501
E117751	450	8	6	6	1580	1	3258951177518
E117752	600	10	8	7	2600	1	3258951177525
E117753	750	11	10	8	3950	1	3258951177532
E117754	900	12	11	9	5450	1	3258951177549
E117755	1050	14	12	10	8100	1	3258951177556

LAMES POUR COUPE-BOULONS

- Livrées avec vis.



	Coupe boulon	Poids g	📦	EAN
E195568	E195561	28	1	3258951955680
E117756	E117750	40	1	3258951177563
E117757	E117751	50	1	3258951177570
E117758	E117752	87	1	3258951177587
E117759	E117753	125	1	3258951177594
E117760	E117754	175	1	3258951177600
E195569	E117755	265	1	3258951955697





CISAILLES

CISAILLES AVIATION COUPE DROITE

→ **ASME B 107.16M**

- Lames forgées : forte démultiplication et écartement des becs par ressort encastré garantissant une utilisation longue durée confortable.
- Coupe précise : lames légèrement striées pour éviter tout risque de glissement.
- Performances de coupe : Inox 80 kg/mm² 0,8 mm
- Acier mi- dur 1,2 mm.
- Confortable : gaine bi-matière.
- Code couleur normalisé.
- E020906 : Longue portée.

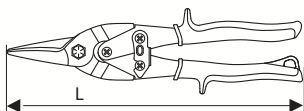

	L mm	l mm	Longueur de lame mm	Poids g	☒	EAN
E214563	250	52	45	399	10	3258952145639
E020906	290	65	82	400	10	3258950209067



CISAILLES AVIATION

→ **ASME B 107.16M**

- Lames forgées - forte démultiplication et écartement des becs par ressort encastré garantissant une utilisation longue durée confortable.
- Coupe précise, lame légèrement striées pour éviter tout risque de glissement.
- Performances de coupe : Inox 80 kg/mm² 0,8 mm
- Acier mi- dur 1,2 mm.
- Confortable : gaine bi-matière.
- Code couleur normalisé suivant le sens de la coupe :
E020902 : Coupe à droite - vert.
E020903 : Coupe à gauche - rouge.

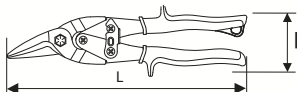

	L mm	l mm	Longueur de lame mm	Poids g	☒	EAN
E020902	248	52	40	400	10	3258950209029
E020903	248	52	40	400	10	3258950209036



CISAILLES DÉMULTIPLIÉES CHANTOURNEUSES

→ **ASME B 107.16M**

- Cisaille type passe franc - forte démultiplication et écartement des becs par ressort encastré garantissant une utilisation longue durée confortable.
- Code couleur normalisé suivant le sens de la coupe :
E020904 : Coupe à droite - vert.
E020905 : Coupe à gauche - rouge.

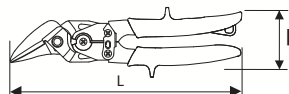

	L mm	l mm	Longueur de lame mm	Poids g	☒	EAN
E020904	248	65	45	380	10	3258950209043
E020905	248	65	45	380	10	3258950209050





CISAILLE CHANTOURNEUSE - LAME FINE

- ASME B 107.16M
- Lames forgées en acier carbone.
- Cisaille conçue pour couper de la tôle de manière précise.
- Performances de coupe : Inox 80 kg/mm² 0,8 mm
- Acier mi-dur 1 mm.
- Poignées gainées PVC.

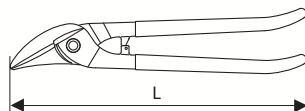

	L mm	l mm	Longueur de lame mm	Poids g	☒	EAN
E184195	270	55	42	380	10	3258951841952

CISAILLE À TÔLE UNIVERSELLE

- 2 lames étroites, coupe à droite, en ligne droite et courbe.
- Lames forgées en acier fin allié.
- Dureté des lames 56 - 60 HRC.
- Performance de coupe : 120 kg/mm² 1,2 mm.
- Lames polies.
- Poignées en laque cuite haute qualité.

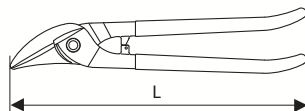
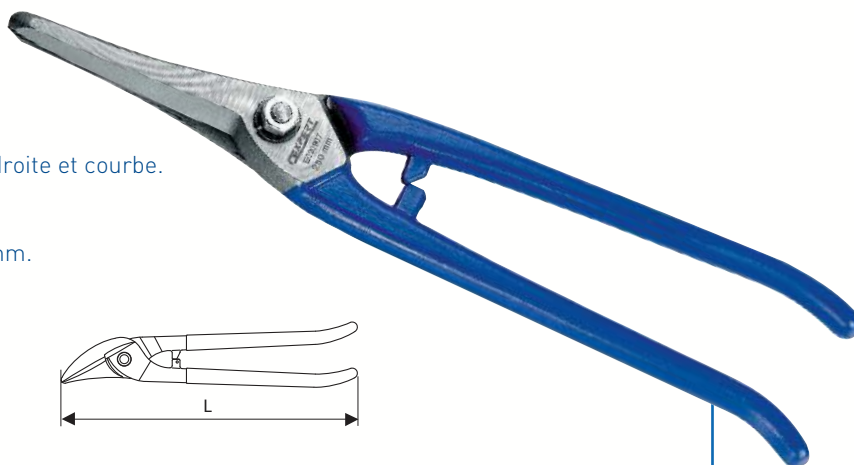

	L mm	Poids g	☒	EAN
E020907	250	470	10	3258950209074

CISAILLE À TÔLE SEMI-UNIVERSELLE

- 1 lame étroite, 1 lame large, coupe à droite, en ligne droite et courbe.
- Lames forgées en acier fin allié.
- Dureté des lames 56 - 60 HRC.
- Performance de coupe : 120 kg/mm² 1,2 mm.
- Lames polies.
- Poignées en laque cuite haute qualité.

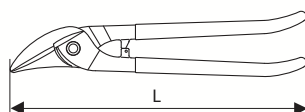

	L mm	Poids g	☒	EAN
E020908	260	476	10	3258950209081





CUTTERS

CUTTER 9 MM

- lame sécable.
- Casse lame amovible dans le capuchon.
- Clip de poche intégré.
- Stockage pour 1 lame de rechange.
- Livré avec 2 lames.



E020301	L mm	Poids g		EAN
E020301	140	28	10	3258950203010

LAMES DE CUTTERS 9 MM

- 10 segments de lame sécable.

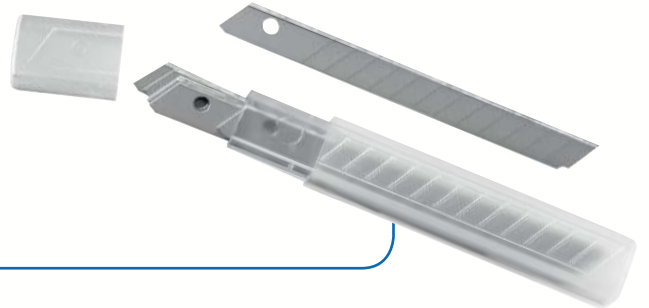

E020303	Poids g		EAN
E020303	35	10	3258950203034

CUTTER 18 MM

- lame sécable.
- Casse lame amovible dans le capuchon.
- Stockage pour 1 lame de rechange.
- Livré avec 2 lames.



E020302	L mm	Poids g		EAN
E020302	160	74	10	3258950203027

LAMES DE CUTTERS 18 MM

- 10 segments de lame sécable.

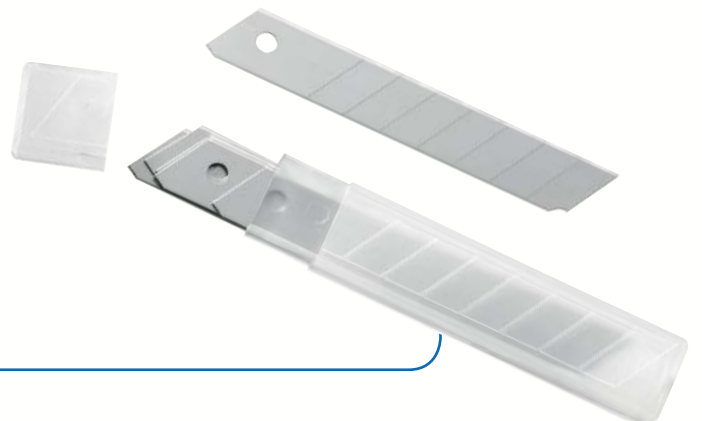

E020304	Poids g		EAN
E020304	92	10	3258950203041



COUPEAU

COUPEAU DE SÉCURITÉ

- Rappel automatique de la lame en fin d'application.
- Fourni avec une lame.
- Fente coupe fil.



	Poids g		EAN
E020306	130	12	3258950203065

JEU DE 12 LAMES



	Poids g		EAN
E020307	48	25	3258950203072

CISEAUX

CISEAUX

- Lame droite large.
- Finition : Nickel
- Gaines en nylon.



	L mm	Poids g		EAN
E051601	145	100	5	3258950516011

CISEAUX

Voir section Électricité - Électronique p 212.



COUPE-TOUT

CISAILLE COUPE-TOUT

- Performant : coupe tout type de matériau : carton, caoutchouc, pvc, cuir 5 mm, tôle fine, câble électrique.
- Indispensable, il vous garantira une coupe précise et nette grâce à ses lames légèrement crantées.
- Sûr : blocage en position fermée.
- Confortable : gaine bi-matière.
- Longueur de lame 58 mm.

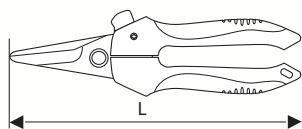

	L mm	Poids g		EAN
E020901	190	201	1	3258950209012



ÉCLAIRAGE





Projecteurs

P.196



Lampes d'inspection

P.198



Rampe d'éclairage

P.200

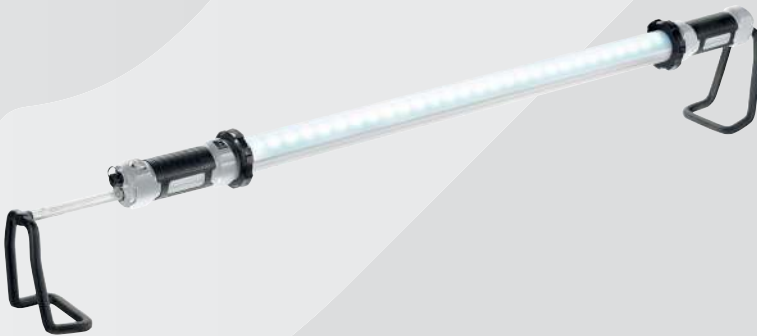

Lampes flexibles

P.201





PROJECTEURS

PROJECTEUR FILAIRE 35W

- 1 LED COB 35W.
- Puissance d'éclairage : 1200 lumens ou 3500 lux à 1 m.
- IP 65.
- Crochet de suspension.
- Peut-être utilisé avec les deux supports :
E201424 : Support au sol.
E201425 : Trépied.
- Dimensions : 250 x 185 x 87 mm.



E201412	Poids g		EAN
E201412	1980	1	3258952014126

PROJECTEUR RECHARGEABLE 15W SUR SUPPORT

- 1 LED COB 15W.
- Deux niveaux de puissance d'éclairage :
8W : 600 lumens ou 350 lux à 1 m.
15W : 1200 lumens ou 600 lux à 1 m.
- Autonomie :
8W : jusqu'à 7 heures.
15W : jusqu'à 3,5 heures.
- Temps de charge : 3-4 heures.
- Livré avec chargeur secteur.
- IP 65.
- Support au sol fourni (E201424).
- Peut-être utilisé avec le trépied (E201425).
- Dimensions : 187 x 138 x 80 mm.



E201411	Poids g		EAN
E201411	2154	1	3258952014119



TRÉPIED

- Trépied pour projecteur filaire 35W E201412 et pour projecteur rechargeable 15W E201411.
- Réglable en hauteur (mini = 650 mm, maxi = 1850 mm).

E201425	Poids g	📦	EAN
E201425	2450	1	3258952014256



SUPPORT AU SOL

- Support au sol pour projecteur filaire 35W E201412 et pour projecteur rechargeable 15W E201411.
- Poignée de transport.

E201424	Poids g	📦	EAN
E201424	780	1	3258952014249



LAMPES D'INSPECTION

LAMPE STICK

- Lampe rechargeable.
- 1 LED COB haute performance.
- 2 Puissances d'éclairage :
250 lumens / 70 lux à 1 m.
500 lumens / 140 lux à 1 m.
- Autonomie : 2,5 / 5 h.
- Indicateur de battery.
- IP54.
- Equipée de 2 aimants au dos.
- Crochet de suspension.
- Livrée avec câble adaptateur secteur.
- Batteries Li-ion.

E201431	Poids g	📦	EAN
E201431	260	1	3258952014317





LAMPES D'INSPECTION

LAMPE D'INSPECTION FLEXIBLE

- Lampe d'inspection rechargeable.
- 6 LEDs SMD haute performance + 1 LED SMD en bout.
- Puissance d'éclairage principal: 200 lumens / 300 lux à 50 cm.
- Puissance d'éclairage en bout: 50 lumens / 450 lux à 50 cm.
- Autonomie: 5 h éclairage principal. 9 h éclairage en bout.
- Temps de charge: 4,5 h.
- Embase magnétique flexible sur 180°.
- Equipée de 2 aimants au dos et de 2 crochets escamotables.
- Livrée avec adaptateur secteur et cordon allume cigare 12V.
- Batteries Li-ion.
- Dimensions: 50 x 40 x 250 mm.

E201427	Poids g		EAN
E201427	260	1	3258952014270



LAMPE STYLO

- 6 LEDs COB haute puissance + 1 torche LED SMD.
- Puissance d'éclairage principal: 110 lumens : 50 lux à 1 m.
- Puissance d'éclairage en torche : 70 lumens / 35 lux à 1 m.
- IP54.
- 3 x batteries AAA.

E201432	Poids g		EAN
E201432	135	1	3258952014324





LAMPE STYLO RECHARGEABLE USB

- Lampe stylo rechargeable USB.
- 6 LEDs SMD haute puissance + 1 LED en bout.
- Puissance d'éclairage principal : 45 lumens ou 125 lux à 0,5 m.
- Puissance d'éclairage en bout : 3 lumens ou 25 lux à 0,5 m.
- Autonomie : 3 h éclairage principal - 12 h éclairage en bout.
- Dimensions : 18 x 33 x 170 mm.
- Livrée avec un câble USB et accus rechargeables.

	Poids g		EAN
E201406	60	12	3258952014065



MIROIR TÉLESCOPIQUE À LEDS

- Eclairage à LEDs pour une inspection parfaite, même dans les zones sombres.
- Taille extensible : de 290 à 876 mm.
- Tête rotative et angle adaptable pour une visualisation parfaite.
- Deux LEDs pour éviter de créer une ombre sur la zone à observer.
- 1 pile plate 3 volts lithium fournie.

	Poids g		EAN
E051401	115	1	3258950514017



GRIFFE FLEXIBLE MAGNÉTIQUE À LED

- Bras avec une mâchoire 4 griffes.
- Embout magnétique.
- La LED s'active lorsque les griffes avancent.
- 7 lumens ou 100 lux à 0,5 m.
- Corps flexible 252 mm.
- Grandes griffes pour une meilleure prise et plus de contrôle.
- S'utilise d'une seule main.
- Fonctionne avec 3 piles LR44 (inclus).

	Poids g		EAN
E201414	180	1	3258952014140





LAMPES D'INSPECTION

MINI LAMPE MAGNÉTIQUE

- S'allume automatiquement au contact d'objets métalliques qui sont conducteurs.
- Piles fournies.
- 2 LEDs.
- Aimant en V pour s'adapter à tous types d'outils.



E201426	Poids g		EAN
E201426	60	1	3258952014263

RAMPE D'ÉCLAIRAGE

RAMPE D'ÉCLAIRAGE À LED'S - 2 NIVEAUX D'ÉCLAIRAGE

- Rampe d'éclairage rechargeable.
- 28 LEDs SMD haute puissance.
- 2 niveaux de puissance.
- Puissance d'éclairage :
 - 7W : 550 lumens / 240 lux à 1 m.
 - 15W : 1 150 lumens / 440 lux à 1 m.
- Temps operationnel : 7W : 4 h. 15W: 2,5 h.
- Temps de charge: 3,5 h.
- Faisceau orientable.
- 2 crochets extensibles de 1,14 m à 1,90 m.
- Livrée avec adaptateur secteur.
- Batteries Li-ion.
- Dimensions: 1138 x 179 x 96 mm.



E201429	Poids g		EAN
E201429	1500	1	3258952014294



LAMPES FLEXIBLES

LAMPE FLEXIBLE

- 1 LED SMD haute puissance.
- Puissance d'éclairage : 250 lumens ou 1551 lux à 0,5 m.
- Autonomie : 15 h.
- Faisceau d'éclairage à optique réglable.
- Embase magnétique.
- Fonctionne avec 2 piles AAA (non fournies).
- IP 54.
- Dimensions : 40 x 414 mm.

E201409	Poids g	📦	EAN
	350	1	3258952014096



LAMPE FLEXIBLE ULTRA VIOLET

- 7 LEDs UV.
- Autonomie : 25 h.
- Embase magnétique.
- Fonctionne avec 2 piles AAA (non fournies).
- IP 54.
- Dimensions : 40 x 414 mm.

E201410	Poids g	📦	EAN
	335	1	3258952014102



MINI LAMPE FLEXIBLE À LEDS À EMBASE MAGNÉTIQUE

- Idéale pour éclairer les espaces réduits peu accessibles.
- 3 LEDs blanche de 5 mm de diamètre.
- 21 Lumens.
- 150 Lux à 0,5 m.
- Embase magnétique.
- Corps flexible : 440 mm.
- Fonctionne avec 3 piles LR44 (fournies).
- Dimensions : 367 x 7,5 mm.

E201413	Poids g	📦	EAN
	90	1	3258952014133



MAINTENANCE - TUBE - EXTRACTION

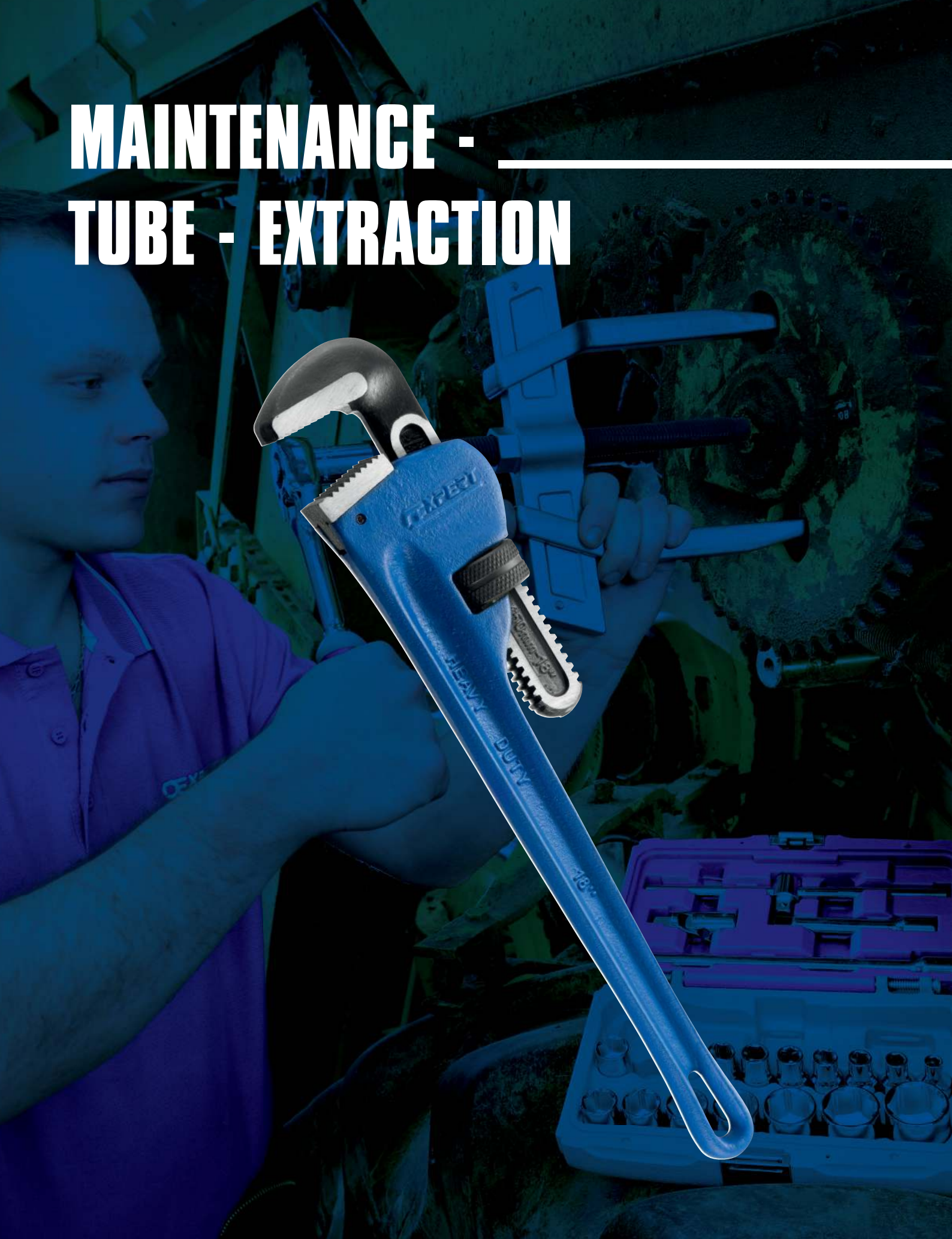



Maintenance

P.204



Outillage tube

P.208



Extraction

P.211





MAINTENANCE

VALISE DE MAINTENANCE

- Pour la maintenance itinérante.
- 124 pièces.
- Détails voir page 21.



	Dimension mm	Poids kg		EAN
E034806	L.565 x P.415 x H.92	8,30	1	3258950348063

GRATTOIR

- Poignée plastique.
- Porte lame métal.
- Lames remplaçables.
- 1 lame fournie.



	Poids g		EAN
E201519	310	1	3258952015192

LAMES DE RECHANGE POUR GRATTOIR

- Pour grattoir E201519.
- En boîte de 5 lames.
- Epaisseur : 0,5 mm.



	Poids g		EAN
E201520	12	1	3258952015208



ETAUX

- Forgé, construction en acier robuste pour une longévité maximale.
- Enclume intégrée.
- Usinage de précision.

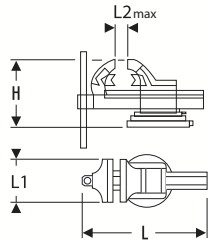

	H mm	L mm	L1 mm	L2 mm	Poids kg	☒	EAN
E090401	148	305	104	100	7.5	1	3258950904016
E090402	165	365	129	125	11	1	3258950904023
E090403	187	406	154	150	14	1	3258950904030
E090404	205	500	205	200	18.5	1	3258950904047

LEVIERS D'EFFORT

- Forgé à partir d'acier en alliage de chrome.
- La forme de la tête agit comme un point d'appui pour augmenter l'effort.



	L mm	Poids g	☒	EAN
E150901	300	234	1	3258951509012
E150902	413	480	1	3258951509029

CLÉS À ÉCHAFAUDAGE

- Spécial montage/démontage d'échafaudages.
- Mécanisme 32 dents.
- Changement de sens par inverseur encastré et protégé.
- Mécanisme à double face donne deux tailles par clé :
E110961 : 17 x 19 mm.
E110962 : 21 x 22 mm.
- Finition : Zinc.

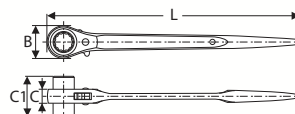
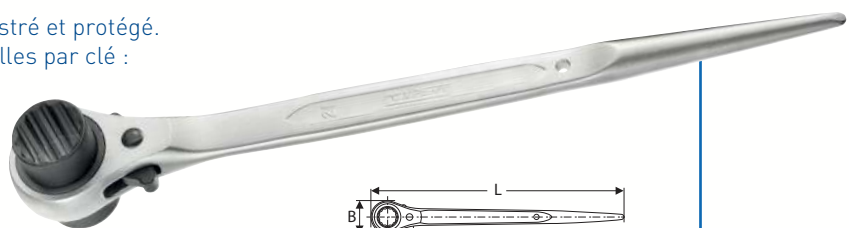

	B mm	C mm	C1 mm	L mm	Poids g	☒	EAN
E110961	40.7	17	50	309	430	1	3258951109618
E110962	40.7	17	50	309	714	1	3258951109625





MAINTENANCE

COUPE VERRE

- Corps acétate.
- Tête en acier nickelé.
- Livré avec 5 molettes dans le barillet.

	L mm	Poids g		EAN
E020305	135	34	1	3258950203058



PINCE À RIVETER

- Bec à 90°.
- 4 buses interchangeable diamètre : 2-3-4-5 mm.
- Ejection automatique de la tige du rivet.
- Clé à buse incorporée.
- Construction durable en acier.
- Livrée avec une sélection de 15 rivets en aluminium.

	L mm	Poids g		EAN
E169804	200	572	1	3258951698044



PINCE EMPORTE PIÈCE REVOLVER

- Pour diamètres de : 3-3,2-3,5-4-4,5-5.
- Pour cuir, toile, caoutchouc...
- Finition : chromée.

	L mm	Poids g		EAN
E090303	220	280	1	3258950903033



MOUSSE REPOSE GENOUX

- Possibilité d'insérer deux lampes pour éclairer la zone de travail souhaitée.
- Surface traitée pour résister aux liquides et à une utilisation répétée.
- Poignée de transport.
- Taille adaptée pour tenir dans une boîte à outils textile ou dans le sac à dos à roulettes.
- Dimensions : L.428 x P.250 x H.32 mm.



	Poids g		EAN
E200131	160	1	3258952001317



BURETTES

- Pompe à dépression.
- Tuyau rigide avec buse en cuivre.



	Contenant	Poids g	☒	EAN
E090701	300 ml	215	1	3258950907017
E090702	500 ml	310	1	3258950907024

PISTOLET À GRAISSE

- Pression : 400 bars.
- Tuyau rigide.
- Flexible (L. 230 mm D. 14 mm).
- Utilisation avec graisse en cartouche ou graisse en vrac.
- Capacité : 500 cm³ ou 400 g.



	Poids g	☒	EAN
E090705	1145	1	3258950907055

PISTOLET À SILICONE

- Modèle professionnel.
- Tube en aluminium.
- Poignée ergonomique.



	Poids g	☒	EAN
E090703	875	1	3258950907031





OUTILLAGE TUBE

CLÉS SERRE TUBES TYPE SUÉDOISE 45°

- Corps en acier au chrome vanadium.
- Mâchoire inclinées à 45 degrés.
- Vernies.

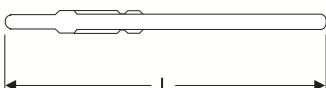
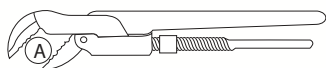

	A max "	A max mm	L mm	Poids g		EAN
E090106	1/2"	40	270	480	1	3258950901060
E090107	1"	60	340	800	1	3258950901077
E090108	1 1/2"	65	430	1400	1	3258950901084
E090109	2"	85	550	2350	1	3258950901091



CLÉS SERRE TUBES TYPE SUÉDOISE 90°

- Corps en acier au chrome vanadium.
- Mâchoire inclinées à 90 degrés.
- Vernies.

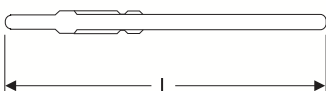
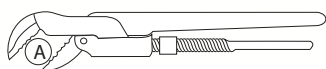

	A max "	A max mm	L mm	Poids g		EAN
E090110	1"	65	330	800	1	3258950901107
E090111	1 1/2"	85	420	1350	1	3258950901114
E090112	2"	100	540	2500	1	3258950901121
E090113	3"	150	630	4200	1	3258950901138



CLÉS SERRE TUBES EN ALUMINIUM

- Corps en aluminium.
- Mâchoire fixe en acier forgé.
- Vernies.

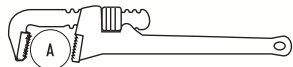
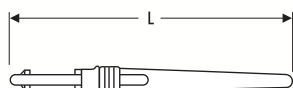

	A max "	A max mm	L mm	Poids g		EAN
E090114	2 1/2"	76	450	1340	1	3258950901145
E090115	3"	90	600	2230	1	3258950901152
E090116	5"	142	900	4000	1	3258950901169





CLÉS SERRE TUBES

- Corps en fonte.
- Mâchoire fixe en acier forgé.
- Traitement haute fréquence des mâchoires pour une grande résistance et une parfaite prise des tubes.

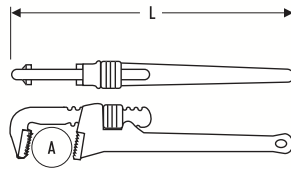

	A max "	A max mm	L mm	L "	Poids kg	📦	EAN
E117820	1"	26	200	8	0,40	1	3258951178201
E117821	1"1/4	33	250	10	0,78	1	3258951178218
E117822	1"3/4	48	350	14	1,50	1	3258951178225
E117823	2"1/4	60	450	18	2,40	1	3258951178232
E117824	2"3/4	75	600	24	4	1	3258951178249
E117825	4"	102	900	36	9	1	3258951178256

PINCE SERRE TUBES

- ISO 8976.
- 7 positions de réglage.
- Finition : acier inoxydable peint.



	L mm	Profondeur de mâchoire mm	Poids g	📦	EAN
E090105	250	33	350	1	3258950901053

PINCE À GAZ

- Pince pour le serrage de tubes de différents diamètres (4 à 30 mm).
- Finition : tête polie, branches laquées.



	L mm	Poids g	📦	EAN
E090104	230	380	1	3258950901046





OUTILLAGE TUBE

CLÉ UNIVERSELLE À SANGLE

- Sangle en caoutchouc.
- Pour diamètre de 30 à 160 mm.

	Poids g		EAN
E200240	341	1	3258952002406

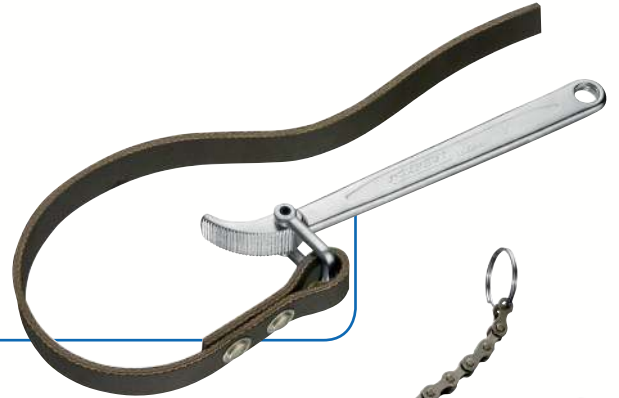

CLÉ À CHAÎNE

- Chaîne en acier.
- Pour diamètre de 30 à 160 mm.

	Poids g		EAN
E200241	421	1	3258952002413



CLÉS A SANGLE

- Corps aluminium.
- Sangle nylon.

	A max "	A max mm	L mm	Poids g		EAN
E117827	125	4	315	290	1	3258951178270
E117828	165	6	315	310	1	3258951178287



SANGLES DE RECHANGE

	Clés à sangle		EAN
E090101	E117827	1	3258950901015
E090102	E117828	1	3258950901022

COUPE TUBE CUIVRE

- Capacité de coupe tube Ø 16 mm maxi (E117829).
- Capacité de coupe tube Ø 32 mm maxi (E117830).
- Réglage facile et rapide par molette.
- Ebavureur intégré.
- Livré avec lame de rechange.



	L mm	Poids g		EAN
E117829	55	120	1	3258951178294
E117830	140	300	1	3258951178300



EXTRACTION

EXTRACTEUR 2 GRIFFES

- Transformation possible en prise intérieure ou extérieure avec la même griffe.
- Fabriqué en acier au chrome vanadium.
- Finition : chromé.

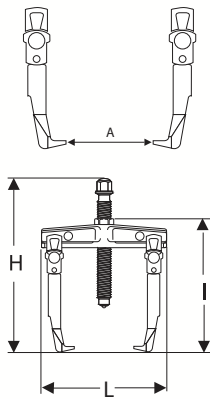

	L x l x H mm	A mm	B mm	T kN	Griffes	Vis	Poids kg	☒	EAN
E096002	115 x 105 x 133	65	14	15	E096007	E096010	0.4	1	3258950960029
E096003	146 x 155 x 182	90	17	30	E096008	E096011	0.9	1	3258950960036
E096004	186 x 155 x 182	130	17	30	E096009	E096011	1	1	3258950960043
E096005	247 x 233 x 283	175	22	40	E096009	E096012	2.8	1	3258950960050
E096006	297 x 233 x 283	220	22	40	E096009	E096012	3	1	3258950960067

GRIFFES

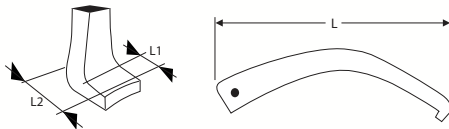

	L mm	L1 mm	L2 mm	Poids g	☒	EAN
E096007	100	10	16	82	1	3258950960074
E096008	155	15	24	187	1	3258950960081
E096009	225	22	33	554	1	3258950960098

VIS

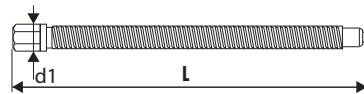

	L mm	d1 mm	Poids g	☒	EAN
E096010	135	14	150	1	3258950960104
E096011	183	17	199	1	3258950960111
E096012	283	22	434	1	3258950960128



ÉLECTRICITÉ - ÉLECTRONIQUE





Sertissage

P.214



Outil à dégainer

P.215



Pincés isolées 1000 volts

P.216



Tournevis testeur

P.220



Ciseaux d'électricien

P.220



Tournevis de précision

P.222



Pincés électroniques

P.224



Coupe-câbles

P.214



Pincés à dénuder

P.215



Tournevis isolés 1000 volts

P.218



Couteaux d'électricien

P.220



Fer à souder

P.220



Pincés brucelles

P.223





SERTISSAGE

PINCE À SERTIR BI-MATIÈRE

- Matrice 3 empreintes de 0,4 à 6 mm².
- Pour cosses avec isolants PVC, PC et polyamide.
- Double sertissage pour sertir en 1 seule opération le contact et l'isolant.
- Manche bi-matière pour un meilleur confort.



	L mm	Poids g		EAN
E050301	235	568	1	3258950503011

PINCE À SERTIR POUR COSSES NON ISOLÉS

- Matrice trois empreintes de 0,5 à 6mm².
- Pour cosses non isolés.
- Manche bi-matière.



	L mm	Poids g		EAN
E050302	235	480	1	3258950503028

PINCE À SERTIR

- Sertissage de cosses pré-isolées de 1,5 - 2,5 - 6 mm² maxi et cosses tubulaires de 1,5 à 6 mm² maxi.
- Dénudage de 0,75 à 6 mm² maxi.



	L mm	Poids g		EAN
E117903	220	260	1	3258951179031

COUPE-CÂBLES

COUPE-CÂBLES CUIVRE

- ISO 5749
- Capacité de coupe : fils de cuivre de 12 mm de diamètre maxi.
- Gainage bi-matière.



	Poids g		EAN
E189874	270	1	3253561898747



OUTIL À DÉGAINER

OUTIL À DÉGAINER

- Lame pivotante pour une coupe circulaire et longitudinale.
- Poignée plastique.
- Livrée avec une lame de rechange dans la poignée.
- Capacité maximum: \varnothing 28 mm.



E050103	L mm	Poids g	☒	EAN
	140	65	1	3258950501031

LAME DE RECHANGE

- Pour outil à dénuder E050103.



E050104	☒	EAN
	1	3258950501048

PINCES À DÉNUDER

PINCE À DÉNUDER AUTOMATIQUE

- Sertissage pour cosses pré-isolées : 0,5 à 6 mm².
- Sertissage pour cosses nues : 0,5 à 2,5 mm² et 4 à 6 mm².
- S'ajuste automatiquement pour les câbles de 0,2 à 6 mm.
- Fonction coupe file.

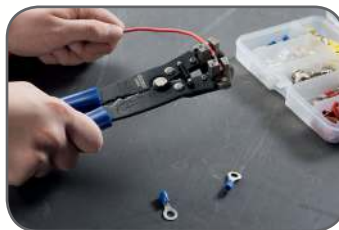

E050105	L mm	Poids g	☒	EAN
	216	270	1	3258950501055

PINCE À DÉNUDER DE 170 MM

- Parfaite pour dénuder les fils multibrins et monobrins de 0,75 à 6 mm².
- Poignée ergonomique pour un meilleur confort.
- Fabriquée en France.

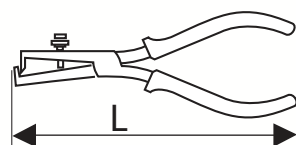

E050106	L mm	Poids g	☒	EAN
	170	185	1	3258950501062





PINCES ISOLÉES 1000 VOLTS

PINCE COUPANTE HAUTES PERFORMANCES - ISOLÉE 1000 V

- IEC EN 60900 - DIN ISO 5745
- Tête compacte pour un accès facilité dans les espaces confinés (armoires électriques).
- Taillants conçus pour couper net les fils tendres (cuivre) et mi-durs.
- Poignée ergonomique pour un meilleur confort lors de coupes très répétitives.
- Corde à piano E050406 Maxi 1,6 mm 220 kg/mm².
- Corde à piano E050407 Maxi 1,8 mm 215 kg/mm².
- Fabriquée en France.



	L mm	Poids g		EAN
E050406	160	200	1	3258950501062
E050407	180	260	1	3258950504070

PINCES DEMI-RONDES BECS DROITS - ISOLÉES 1000 V

- IEC EN 60900 - DIN ISO 5745
- Becs fins pour un accès facilité dans les espaces confinés (armoires électriques).
- Becs finement striés avec coupe-fil latéral - Maxi 1,6 mm 160 kg/mm².
- Poignée spéciale ergonomique pour un meilleur confort lors de coupes longues et très répétitives.
- Fabriqué en France.



	L mm	Poids g		EAN
E050408	160	177	1	3258950504087
E050409	200	192	1	3258950504094

JEU DE 2 PINCES - ISOLÉES 1000 V

- IEC EN 60900
- Contient :
 - Pince coupante diagonale 160 mm : E050406
 - Pince à dénuder 170 mm : E050416
- Fabriqué en France.

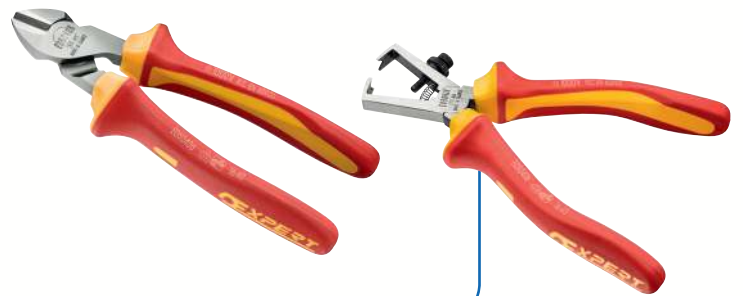

	Quantité	Poids g		EAN
E050504	2	565	1	3258950505046

PINCE MULTIPRISE - ISOLÉE 1000 V

- IEC EN 60900 - DIN ISO 8976
- 6 positions un réglage optimal.
- Ouverture maximale des mâchoires 36 mm
- Poignée ergonomique bimatériel.
- Finition vernie.
- Fabriqué en France.

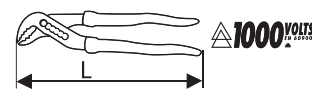

	L mm	Poids g		EAN
E050415	240	365	1	3258950504155



PINCE À DÉNUDER 170 MM - ISOLÉE 1000 V

- CEI EN 60900
- Parfaite pour dénuder les fils multi-brins et mono-brins de 0,75 à 6 mm².
- Poignée ergonomique pour un meilleur confort.
- Fabriqué en France.



	L mm	Poids g	☒	EAN
E050416	160	185	1	3258950504162

JEU DE 3 PINCES - ISOLÉES 1000 V

- CEI EN 60900
- Contient :
 - Pince coupante diagonale 160 mm : E050406
 - Pince à becs droits 160 mm : E050408
 - Pince universelle 180 mm : E050413
- Fabriqué en France.



	Quantité	Poids g	☒	EAN
E050502	3	730	1	3258950505022

PINCES DEMI-RONDES À BECS COUDÉS À 40° - ISOLÉES 1000 V

- IEC EN 60900 - DIN ISO 5745
- Becs fins pour un accès facilité dans les espaces confinés (armoires électriques).
- Becs finement striés avec coupe-fil latéral - Maxi 1,6 mm 160 kg/mm².
- Poignée spéciale ergonomique pour un meilleur confort lors de coupes longues et très répétitives.
- Fabriqué en France.



	L mm	Poids g	☒	EAN
E050410	160	177	1	3258950504100
E050411	200	192	1	3258950504117

PINCE UNIVERSELLE - ISOLÉE 1000 V

- IEC EN 60900 - DIN ISO 5745
- Conçue pour toutes les applications de serrage et de coupe. Taillants conçus pour couper tous types de fils (tendres, mi-durs et durs).
- Poignée ergonomique pour un meilleur confort lors d'utilisations longues et répétitives.
- Corde à piano E050412 Maxi 1,6 mm 220 kg/mm²
- Corde à piano E050413 Maxi 1,8 mm 215 kg/mm²
- Corde à piano E050414 Maxi 2 mm 210 kg/mm²
- Fabriquée en France



	L mm	Poids g	☒	EAN
E050412	160	195	1	3258950504124
E050413	180	225	1	3258950504131
E050414	200	300	1	3258950504148





TOURNEVIS ISOLÉS 1000 VOLTS

JEU DE 10 TOURNEVIS ISOLÉS 1000 VOLTS

→ EN 60900

- Tournevis pour vis à fente : 2,5 x 50 - 3,5 x 75 - 4 x 100 - 5,5 x 150 mm.
- Tournevis Pozidriv® : PZ1 x 100 - PZ2 x 125.
- Tournevis Phillips® : PH0 x 75 - PH1 x 100 - PH2 x 125.
- Tournevis testeur 100/500 Volts.



	Quantité	Poids g		EAN
E160912	10	670	5	3258951609125

JEU DE 6 TOURNEVIS FENTE-PHILLIPS® ISOLÉS 1000 VOLTS

→ EN 60900

- Tournevis pour vis à fente : 2,5 x 50 - 3,5 x 75 - 4 x 100 - 5,5 x 150 mm.
- Tournevis Pozidriv® : PZ1 x 100 - PZ2 x 125.



	Quantité	Poids g		EAN
E160910	6	430	5	3258951609101

JEU DE 6 TOURNEVIS FENTE-POZIDRIV® ISOLÉS 1000 VOLTS

→ EN 60900

- Tournevis pour vis à fente : 2,5 x 50 - 3,5 x 75 - 4 x 100 - 5,5 x 150 mm.
- Tournevis Pozidriv® : PZ1 x 100 - PZ2 x 125.



	Quantité	Poids g		EAN
E160911	6	430	5	3258951609118



TOURNEVIS ISOLÉS 1000 VOLTS POUR VIS À FENTE

→ CEI 60900 - ISO 2380 - 1 - ISO 2380 - 2

- Manche ergonomique tri-matière confortable et efficace.
- Code couleur empreinte : rouge.
- Chaque produit est testé sous 10 000 Voltios.
- Lame ronde, brunie avec isolation en PVC orange.

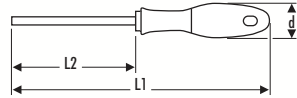
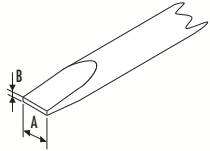

	A x L2 x B mm	L1 mm	d mm"	Poids g	📦	EAN
E165410	2,5 x 50 x 0,4	149	20	18	5	3258951654101
E165413	2,5 x 50 x 0,4	255	32	84	5	3258951654132
E165411	3,5 x 75 x 0,6	177	27	38	5	3258951654118
E050608	3,5 x 100 x 0,6	202	27	40	1	3258950506081
E165412	4,0 x 100 x 0,8	202	27	43	5	3258951654125
E050609	4,0 x 150 x 0,8	252	27	48	51	3258950506098
E165420	6,5 x 150 x 1,2	266	40	134	5	3258951654200

TOURNEVIS ISOLÉS 1000 VOLTIOS POUR VIS PHILLIPS®

→ CEI 60900 - ISO 2380-1 - ISO 2380-2

- Manche ergonomique tri-matière confortable et efficace.
- Code couleur empreinte : jaune.
- Chaque produit est testé sous 10 000 Voltios.
- Lame ronde, brunie avec isolation en PVC orange.

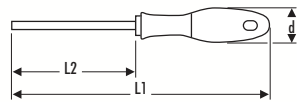
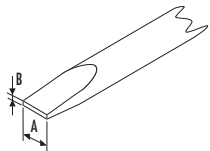

	L1 mm	L2 mm	d mm"	Poids g	📦	EAN
E165414	177	75	27	40	5	3258951654149
E165415	205	100	32	68	5	3258951654156
E165416	230	125	32	89	5	3258951654163
E165421	355	150	40	123	5	3258951654217

TOURNEVIS ISOLÉS 1000 VOLTS POUR VIS POZIDRIV®

→ CEI 60900 - ISO 2380-1 - ISO 2380-2

- Manche ergonomique tri-matière confortable et efficace.
- Code couleur empreinte : bleu.
- Chaque produit est testé sous 10 000 Volts.
- Lame ronde, brunie avec isolation en PVC orange.

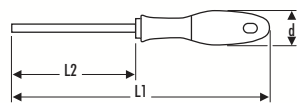
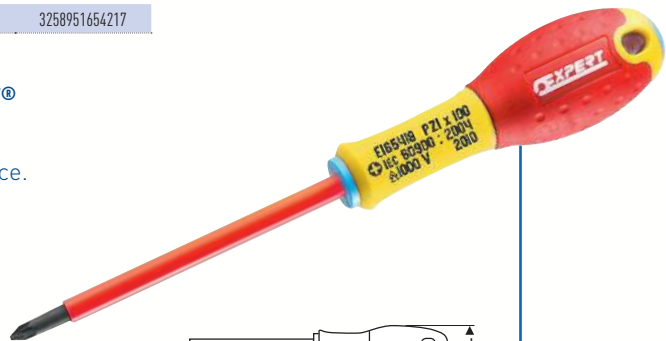
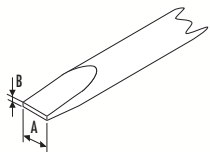

	L1 mm	L2 mm	d mm"	Poids g	📦	EAN
E165418	205	100	32	68	5	3258951654187
E165419	230	125	32	89	5	3258951654194
E165417	177	75	27	40	5	3258951654170
E165422	355	150	40	123	5	3258951654224





TOURNEVIS TESTEUR

TOURNEVIS TESTEUR

- 100/250 Volts.
- Dimension lame : 3 x 66 mm.



E161101	Poids g		EAN
E161101	22	60	3258951611012

COUTEAUX D'ÉLECTRICIEN

COUTEAU ÉLECTRICIEN AVEC DÉNUDEUR

- Lame dotée de 2 encoches pour dénuder et couper.
- Lame inox.
- Manche bois.

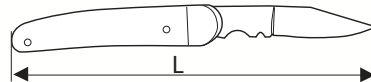

E117762	L mm	Poids g		EAN
E117762	180	77	1	3258951177624

COUTEAU ÉLECTRICIEN 1 LAME

- Lame serpette inox 60 mm.
- Manche bois.

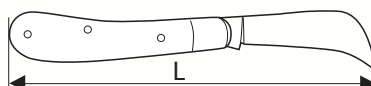

E117763	L mm	Poids g		EAN
E117763	170	85	1	3258951177631

COUTEAU ÉLECTRICIEN 2 LAMES

- Lame serpette inox 60 mm.
- Lame droite inox 80 mm.
- Manche bois.

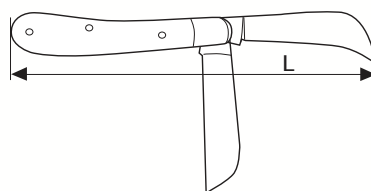

E117767	L mm	Poids g		EAN
E117767	170	115	1	3258951177679



CISEAUX D'ÉLECTRICIEN

CISEAUX ÉLECTRICIEN

- Lame courte renforcée avec coupe fil.
- Matière : acier carbone.
- Finition chromée polie.
- Poignée gainée PVC.



	L mm	Poids g		EAN
E117764	150	117	1	3258951177648

CISEAUX BI-MATIÈRE

- Lame longue dotée d'une encoche coupe fil.
- Matière inox.
- Poignée bi-matière.



	L mm	Poids g		EAN
E184280	145	62	1	3258951842805

CISEAUX
Voir section Coupe p 193.



FER À SOUDER

FER À SOUDER

- Livré avec flamme et embout de \varnothing 1,2 mm.
- Rechargeable au gaz butane.
- Livré avec notice d'utilisation.
- Livré avec un embout chalumeau.



	L mm	d mm"	Poids g		EAN
E090501	170	19	70	1	3258950905013

POINTES DE RECHANGE

	d mm"	Poids g		EAN
E090502	1,2	6	1	3258950905020





TOURNEVIS DE PRÉCISION

JEU DE 6 TOURNEVIS DE PRÉCISION

- Pour vis à fente : 2,0 x 40 - 2,5 x 40 - 3,0 x 40.
- Pour vis Phillips® : PH 000 - PH 00 - PH 0.



E161102	Quantité	Poids g		EAN
E161102	6	155	1	3258951611029

COFFRET DE TOURNEVIS MULTILAMES DE PRÉCISION

- Jeu en coffret plastique composé de :
- 1 porte-lame.
- 6 lames fente : 1,2-1,5-1,8-2-2,5
- 2 lames Phillips® : PH000-PH00.



E161109	Poids g		EAN
E161109	80	1	3258951611098



PINCES BRUCELLES

BRUCELLE LONGUE MODÈLE DROIT - 160 MM

- Becs striés droits.
- Acier inoxydable, finement poli.
- Revêtement PVC bleu.



	L mm	Poids g		EAN
E501201	160	44	1	3258955012013

BRUCELLE LONGUE MODÈLE COUDÉ - 155 MM

- Becs striés coudés à 35°.
- Acier inoxydable, finement poli.
- Revêtement PVC bleu.



	L mm	Poids g		EAN
E501202	155	44	1	3258955012020

BRUCELLE MODÈLE DROIT

- Becs striés droits.
- Acier inoxydable anti-magnétique - anti-acide.



	L mm	Poids g		EAN
E501203	120	12	1	3258955012037





PINCES ÉLECTRONIQUES

PINCE À BECS EFFILÉS DROITS

- Becs lisses pour une meilleure protection des pièces.
- Finesse des becs pour une excellente accessibilité.
- Gainage bi-matière soft pour une bonne prise en main.



	L mm	Poids g	📦	EAN
E117877	132	25	1	3258951178775



PINCE À BECS PLATS

- Becs striés pour une bonne tenue de pièce.
- Grande robustesse des becs.
- Gainage bi-matière soft pour une bonne prise en main.



	L mm	Poids g	📦	EAN
E117883	137	20	1	3258951178836



PINCE À BECS EFFILÉS COURBÉS

- Becs lisses pour une meilleure protection des pièces.
- Finesse des becs pour une excellente accessibilité.
- Gainage bi-matière soft pour une bonne prise en main.



	L mm	Poids g	📦	EAN
E117878	133	35	1	3258951178782





PINCES COUPANTES AXIALES TRAPUES

- Tête ogivale pour une grande robustesse.
- Excellente polyvalence de coupe.
- Gainage bi-matière soft pour une bonne prise en main.



	L mm	d mm corde à piano	d mm fil acier	Poids g	📦	EAN
E117879	115	0.8	1	64	1	3258951178799
E117880	110	0.5	0.8	64	1	3258951178805

PINCE COUPANTE À RAS FINE

- Tête fine pour une parfaite accessibilité.
- Coupe nette et précise.
- Gainage bi-matière soft pour une bonne prise en main.

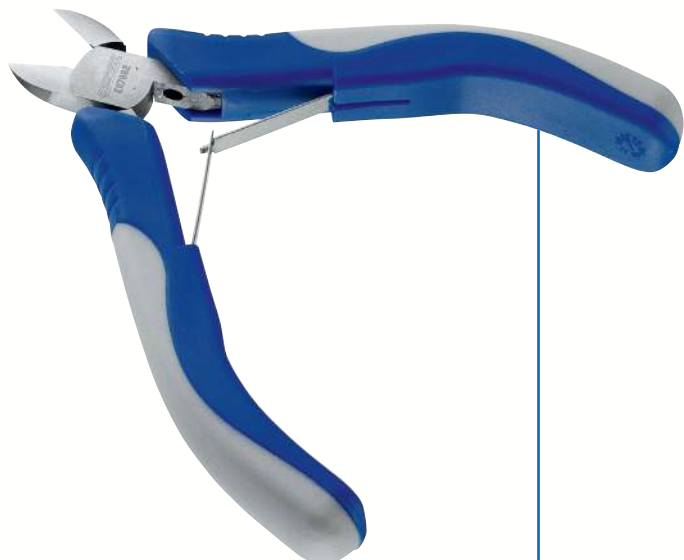

	L mm	Poids g	📦	EAN
E117882	110	20	1	3258951178829



OUTILLAGE AUTOMOBILE





Équipement d'atelier

P.228



Vidange-filtration

P.232



Bougies

P.237



Electricité auto

P.239



Moteur

P.243



Freins

P.248



Suspension

P.250



Roues

P.251



Carrosserie

P.255



Pare-brise

P.257





ÉQUIPEMENT D'ATELIER

CRIC 3T

- Hauteur minimum sous caisse 140 mm, levée maxi 520 mm.
- Roues en métal.
- Conformité CE.
- Dimensions: 720 x 345 x 185 mm.



E200141	Capacité T	Poids kg		EAN
E200141	3	36,7	1	3258952001416

PULVÉRISATEUR PROFESSIONNEL

- Pulvérisateur professionnel 5 litres.
- Équipé d'une brosse pour le lavage des voitures en ateliers.
- Pression jusqu'à 3 bars.
- Réglage du jet possible.
- Cuve graduée.



E200140		EAN
E200140	1	3258952001409

CHARIOT

- Charge admissible de 150 kg.
- Pliable.
- Tapis anti-dérapant.
- 2 roues pivotantes.
- Dimensions : 815 x 738 x 479 mm.



E200135		EAN
E200135	1	3258952001355

DIABLE

- Charge admissible 200 kg.
- Roues gonflables.
- Poignées pivotantes pour une meilleure prise en main.
- Dimensions : 425 x 555 x 1130 mm.



E200136		EAN
E200136	1	3258952001362



PAIRES DE CHANDELLES À CRÉMAILLÈRE

- Système à barre à cliquet.
- Construction forte soudée.
- Pieds larges pour plus de stabilité.

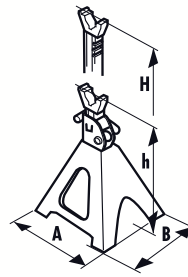

	Capacité T	A mm	B mm	H mm	Poids kg	☒	EAN
E200143	3	206	188	423	6,40	1	3258952001430
E200144	6	294	262	620	13,7	1	3258952001447
E200145	12	382	336	770	32	1	3258952001454

MOUSSE REPOSE GENOUX

- Possibilité d'insérer deux lampes pour éclairer la zone de travail souhaitée.
- Surface traitée pour résister aux liquides et à une utilisation répétée.
- Poignée de transport.
- Taille adaptée pour tenir dans une boîte à outils textile ou dans le sac à dos à roulettes.
- Dimensions: L.428 x P.250 x H.32 mm.



	Poids g	☒	EAN
E200131	160	1	3258952001317

CHARIOT DE VISITE

- 6 roues.
- Support tête mousse.
- 2 bacs range outils.
- Résistant aux hydrocarbures, lavable.
- Dimensions : L.1030 x P.480 x H.115 mm.



	Poids kg	☒	EAN
E200114	4,6	1	3258952001140

JEU DE 2 ROULETTES POUR CHARIOT DE VISITE

- Pour chariot de visite E200114.



	Poids g	☒	EAN
E200124	190	1	3258952001249





ÉQUIPEMENT D'ATELIER

PROTECTION DE CALANDRE

- Pratique : gouttière porte-outils.
- Evite les rayures sur la carrosserie.
- Vinyle épais résistant aux hydrocarbures.
- Dimensions : L.86 x l.66 cm.



	Poids g		EAN
E200116	700	1	3258952001164

EXTRACTEUR DE FLUIDES

- Capacité 9,5 litres.
- Convient pour l'extraction de lubrifiants.
- Pompe pneumatique (utilisation en atelier) ou à main (utilisation en dépannage).
- Corps transparent gradué.
- Sans entretien.
- Livré avec 4 embouts.
- Livré avec notice.

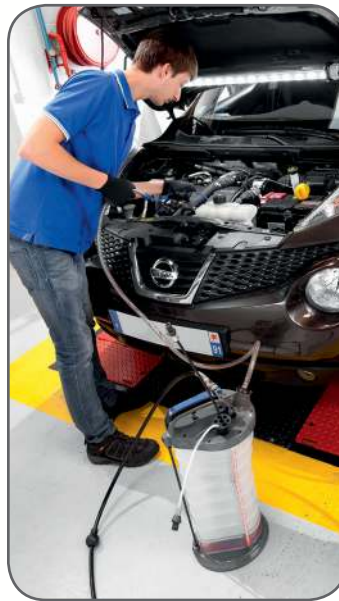

	Poids kg		EAN
E200512	4,51	1	3258952005124

LEVIERS D'EFFORT

- Forgé à partir d'acier en alliage de chrome.
- La forme de la tête agit comme un point d'appui pour augmenter l'effort.

	L mm	Poids g		EAN
E150901	300	234	1	3258951509012
E150902	413	480	1	3258951509029

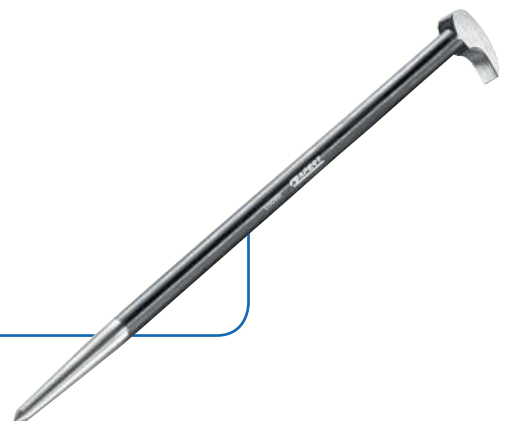



MIROIR TÉLESCOPIQUE À LEDS

- Eclairage deux LEDs.
- Taille extensible : de 290 à 876 mm.
- Tête rotative et angle adaptable.
- 1 pile plate 3 volts lithium fournie.



	Poids g		EAN
E051401	115	1	3258950514017

MIROIR TÉLESCOPIQUE 2 EN 1

- Outil 2 en 1, miroir - doigts magnétique.
- Taille extensible : de 200 à 690 mm.
- Diamètre du miroir : 35 mm.
- Embout magnétique.



	Poids g		EAN
E051402	46	1	3258950514024

DOIGT MAGNÉTIQUE FLEXIBLE

- Manche ergonomique bi-matière confortable et efficace.
- Bras flexible de 409 mm.
- Puissant aimant pouvant soulever jusqu'à 1,4 kg.



	Poids g		EAN
E051501	222	1	3258950515014

GRIFFE FLEXIBLE MAGNÉTIQUE À LED

- Bras flexible de 252 mm.
- 4 griffes.
- Eclairage LED.
- Puissant embout magnétique.
- 3 piles LR44 fournies.



	Poids g		EAN
E201414	180	1	3258952014140





VIDANGE-FILTRATION

SERINGUE POUR CHANGEMENT D'HUILE

- Capacité 1,5 litres.
- Convient pour l'extraction et l'injection de fluides lors de l'entretien du véhicule.
- Double joint pour aspiration continue.
- Robinet permettant de garder la seringue pleine.
- Corps transparent gradué.



	Poids g		EAN
E200231	900	1	3258952002314

BROC VERSEUR

- Broc verseur gradué.
- 5 litres.
- Bouchon à vis.
- Tuyau flexible et amovible.

		EAN
E200244	1	3258952002444



BAC RÉCUPÉRATEUR D'HUILE DE VIDANGE

- Capacité 8 litres.
- Résiste aux chocs et aux hydrocarbures.
- A utiliser lorsque l'on fait une vidange au sol.



	Poids g		EAN
E200227	640	1	3258952002277

BAC DE RÉCUPÉRATION ET STOCKAGE D'HUILE DE VIDANGE

- Capacité 8 litres.
- Résiste aux chocs et aux hydrocarbures.
- Indispensable lorsqu'il est nécessaire de transporter le fluide vidangé.

	Poids g		EAN
E200228	790	1	3258952002284





ENTONNOIR À ROBINET

- Entonnoir 1,2L.
- Robinet d'ouverture et de fermeture.
- Adapté à l'huile de moteur et de boîte de vitesse ainsi qu'au liquide de refroidissement et au carburant.
- Filtre amovible.



E200238	Poids g	📦	EAN
	200	1	3258952002383

ENTONNOIR À HUILE

- Conçu pour le remplissage d'huile moteur.
- Forme rectangulaire permettant de laisser le bidon s'égoutter.
- Egalement adapté à l'huile de boîte de vitesse ainsi qu'au liquide de refroidissement et au carburant.



E200237	Poids g	📦	EAN
	90	1	3258952002376

KIT DE RÉPARATION POUR CARTERS D'HUILE - 64 PIÈCES

- Conçu pour la réparation des filetages de carters d'huile endommagés.
- 64 pièces :
 - 4 tarauds : M13 - M15 - M17 - M20.
 - 5 bouchons par taille : M13.5 - M15.5 - M17.5 - M20.
 - 10 rondelles en aluminium par taille : 13 - 15 - 17 - 20 mm.



E200236	Poids g	📦	EAN
	1410	1	3258952002369

CLÉ DE VIDANGE

- Carrés de 8 et 10 mm.
- Indispensable pour PEUGEOT, CITROEN et RENAULT.



E200202	Poids g	📦	EAN
	300	8	3258952002024





VIDANGE-FILTRATION

JEU DE 13 EMBOUTS DE VIDANGE

- 6 x hexagonale mâle 8 - 10 - 12 - 13 - 14 - 17 mm.
- 4 x carré mâle 8 - 10 - 10,5 - 13,1 mm.
- 1 x carré femelle.
- 1 x XZN®.
- 1 x triangle.

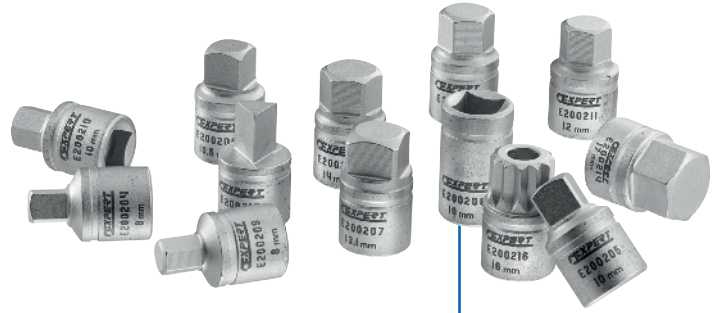

	Quantité	Poids g		EAN
E200203	13	450	3	3258952002031

EMBOUTS DE VIDANGE 3/8" 6 PANS MÂLES

	A mm	Poids g		EAN
E200209	8	28	1	3258952002093
E200210	10	30	1	3258952002109
E200211	12	34	1	3258952002116
E200212	13	36	1	3258952002123
E200213	14	38	1	3258952002130
E200214	17	48	1	3258952002147



EMBOUTS DE VIDANGE 3/8" CARRÉ MÂLE

	A mm	Poids g		EAN
E200204	8	30	1	3258952002048
E200205	10	32	1	3258952002055
E200206	10,50	34	1	3258952002062
E200207	13,10	38	1	3258952002079



EMBOUT DE VIDANGE 3/8" CARRÉ FEMELLE - 10 MM

	Poids g		EAN
E200208	32	1	3258952002086

EMBOUT DE VIDANGE 3/8" XZN® MÂLE - 16 MM

	Poids g		EAN
E200216	36	1	3258952002161



EMBOUT DE VIDANGE 3/8" TRIANGLE MÂLE - 10 MM

	Poids g		EAN
E200215	26	1	3258952002154



MODULE MOUSSE DÉDIÉ AUX TRAVAUX DE VIDANGE ET DE FILTRATION

- Jeu de 13 embouts de vidange.
- Clé "coiffe" auto-serrante universelle : Ø 65-120 mm.
- Cliquet à tête articulée 3/8".
- Clé à filtre de 60 à 110 mm. Essence et diesel.

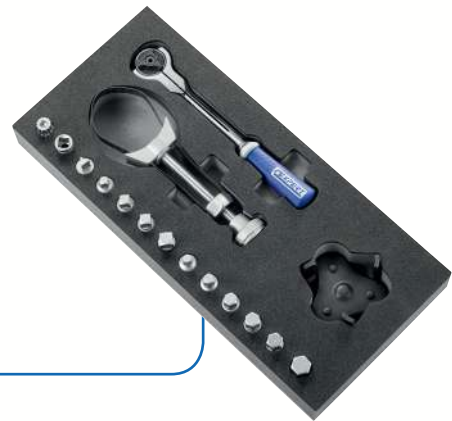

E200245	1	EAN
		3258952002451

CLÉ RÉGLABLE POUR FILTRE À HUILE

- Pour les filtres de 60 à 110 mm.
- Pour la plupart des filtres à huile VL, VUL.

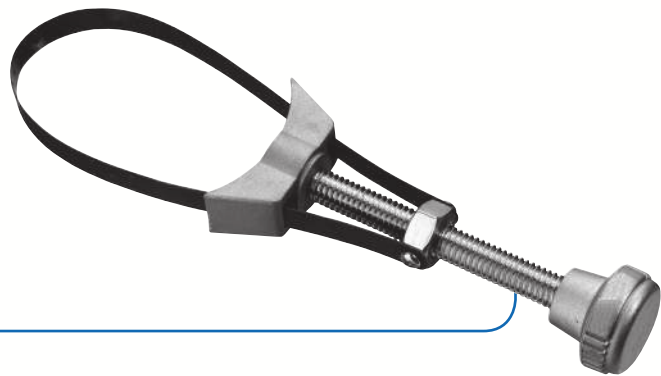

E117117	Poids g	10	EAN
	250		3258951171172

CLÉ RÉGLABLE POUR FILTRE À HUILE - PL

- Pour les filtres de 110 à 165 mm.
- Pour la plupart des filtres à huile PL.



E200219	Poids g	1	EAN
	350		3258952002192

CHAINES 1/2" POUR FILTRE À HUILE

- ISO 1174 - DIN 3122.



E200234	d max mm	Poids g	1	EAN
	120	260		3258952002345
E200235	d max mm	Poids g	1	EAN
	160	315		3258952002352





VIDANGE-FILTRATION

JEU DE CLÉS "COIFFES" POUR FILTRES À HUILE

- 30 pièces.
- Entraînement 3/8".
- Adaptateur 3/8" à 1/2".
- Coiffe auto-serrante universelle incluse.
- Ce jeu couvre 85% des filtres à huile des marques des groupes suivants : PSA, RENAULT, FIAT, ALFA, LANCIA, VAG, BMW, MERCEDES, VOLVO, SAAB, ROVER, JAGUAR, LOTUS, TOYOTA, SUZUKI.



	Quantité	Poids kg		EAN
E200201	30	7	1	3258952002017

CLÉ "COIFFE" AUTO-SERRANTE UNIVERSELLE

- Ø : 65-120 mm.



	Poids g		EAN
E200229	450	1	3258952002291

COFFRET DE 6 DOUILLES "COIFFES" EN ALUMINIUM

- Coiffes pour couvercles plastiques de filtres à huiles.
- Entraînement 1/2".
- Profil 6 pans.
- Ø 24-27-30-32,5-36-38 mm.



	Poids g		EAN
E200239	500	1	3258952002390



BOUGIES

JEU DE 6 DOUILLES À BOUGIES DE PRÉCHAUFFAGE

- 6 douilles à bougies : Ø 8 – 9 – 10 – 12 – 14 – 16 mm.
- Cardan à friction permettant l'inclinaison désirée de la douille.
- Carré 3/8".



	Poids g	☒	EAN
E200311	1615	1	3258952003113

DOUILLES À BOUGIE

- ISO 11168.

	☒	d mm"	Pans	L mm	Poids g	☒	EAN
E200301	3/8"	14	12	63,50	75	1	3258952003014
E200302	3/8"	16	6	63,50	90	1	3258952003021
E200303	3/8"	21	6	70	120	1	3258952003038
E032401	1/2"	5/8"	6	63,50	100	1	3258950324012
E032402	1/2"	13/16"	6	70	160	1	3258950324029
E032101	1/2"	16	6	65	90	1	3258950321011
E032102	1/2"	21	6	70	120	1	3258950321028



CALES D'ÉPAISSEUR MÉTRIQUE

- 19 lames de 0,04 à 1 mm.
- Longueur 90 mm.

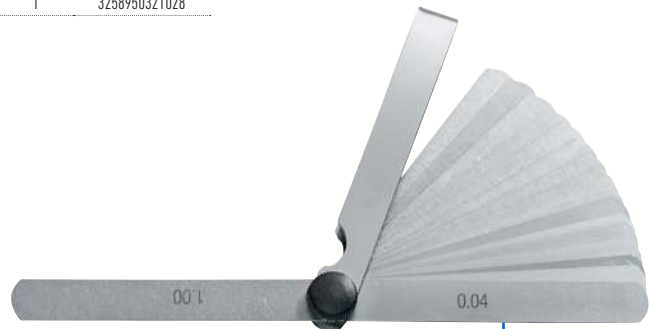

	Poids g	☒	EAN
E200307	60	1	3258952003076

CALES D'ÉPAISSEUR LONGUES MÉTRIQUE

- 19 lames de 0,05 à 1 mm.
- Longueur 150 mm.



	Poids g	☒	EAN
E200312	172	1	3258952003120





JEU DE 4 EXTRACTEURS DE BOBINES D'ALLUMAGE VAG

- Composition de 4 pinces.
- Pour extraire 99% des bobines crayons VAG.
- Livré en coffret plastique avec notice.



	Poids g		EAN
E200503	948	1	3258952005032

KIT DE RÉPARATION POUR BOUGIE D'ALLUMAGE - 16 PIÈCES

Conçu pour la réparation de filetage pour bougies d'allumage.

- 1 taraud étagé M16 entrainement de 17.
- 5 inserts filetage M14 x 125 - 11,2 mm.
- 5 inserts filetage M14 x 125 - 17,5 mm.
- 5 inserts filetage en laiton M14 x 125 - 17,5 mm.



	Poids g		EAN
E200310	330	1	3258952003106

BROSSE MÉTALLIQUE

- Poignée antidérapante.



	Poids g		EAN
E200306	170	12	3258952003069



ELECTRICITÉ AUTO

BOOSTER 12 V

- Tension : 12 V.- Courant de crête : 1600 A.
- Courant de démarrage : 440 A.
- Pour moteur essence et diesel .
- Booster avec adaptateur UK : E200413.



E200408	Poids kg	📦	EAN
E200408	6	1	3258952004080

EXTRACTEUR DE COSES DE BATTERIE

- Convient également pour l'extraction de bras d'essuie-glaces avec ou sans gicleur intégré.
- Capacité de 4 KN.



E201512	Poids g	📦	EAN
E201512	296	1	3258952015123

PORTE-BATTERIE UNIVERSEL

- S'adapte à tous les types de batteries.
- Ouverture maximum 190 mm.
- Poignée confortable.
- Poids maximum porté 27 kg.



E201808	Poids g	📦	EAN
E201808	532	1	3258952018087





PÈSE-ACIDE

- Mesure la densité du liquide de la batterie.
- Lecture à la fois de la densité et du pourcentage de charge.



	Poids g		EAN
E200405	200	1	3258952004059

JEU DE 19 OUTILS POUR EXTRACTION DE FICHES DE CONNECTEURS

- Outils compatibles avec les nouveaux connecteurs du groupe VW-Audi.
- Utilisables sur : capteurs de liquide de refroidissement, faisceaux de câblage et connecteurs calculateurs.
- Préserve le fil et la cosse.
- Poignées moletées.



	Poids g		EAN
E201801	602	1	3258952018018

THERMOMÈTRE INFRAROUGE

- Permet la mesure infrarouge de la température sans contact avec guide laser.
- Permet de vérifier la température du moteur, des disques de freins, du catalyseur ou même d'un système d'air conditionné.
- Infrarouge mesure: -20°C à 520°C
- Rapport D/S (distance / surface) : 8/1.
- Possibilité de désactiver le laser.
- Sélection de valeurs en degrés ou fahrenheit.
- Écran rétro-éclairé.
- Livré avec notice d'utilisation.
- Pile 9V incluse.



	Poids g		EAN
E201805	135	1	3258952018056

TESTEUR DE BATTERIE

- Branchement des pinces sur les cosses de la batterie.
- Réglage du CCA en fonction de la valeur indiquée sur la batterie.
- Mise en charge avec le bouton LOAD et lecture de la valeur directement sur l'écran :
 - Led verte (GOOD / BONNE) : valeur > 10.8V.
 - Led jaune (WEAK / FAIBLE) : 10.8V > valeur > 9.1V.
 - Led rouge (BAD / MAUVAISE) : 9.1V > valeur.



		EAN
E200407	1	3258952004073



MULTIMÈTRE NUMÉRIQUE

- Indispensable pour les diagnostics des pannes électroniques.
- Voltmètre DC / AC : 0 à 250 V.
- Ohmmètre : 0 à 20 MΩ.
- Test diode : 2.8 V / 1 mA.
- Ecran LCD rétro éclairé.
- Mesure de la résistance interne des batteries.
- Protection contre les surcharges.
- Indication de batterie.
- Mesure de température.
- Mise hors tension automatique.
- Testeur de polarité.
- IEC-61010/CAT II 250 V/Norme CE.
- Livré avec 3 piles AAA 1.5 V.
- Livré avec câbles et notice d'utilisation.



	Poids g	☒	EAN
E051301	323	1	3258950513010

MULTIMÈTRE PINCE

- Idéal pour la maintenance itinérante.
- Voltmètre DC / AC : 0 à 600 V.
- Ampèremètre AC : 0 à 400 A.
- Ohmmètre : 0 à 20 MΩ.
- Continuité <30 Ω.
- Diamètre maximum de câble mesurable : ø 32 mm.
- Mesure des courants sans contact lisibles sur écran LCD.
- Test diodes.
- Fonction de maintien des données.
- Protection contre les surcharges.
- IEC-61010/RMS CAT III 600 V/Norme CE.
- Livré avec pochette de protection, câbles et notice d'utilisation.



	Poids g	☒	EAN
E201803	325	1	3258952018032





TESTEUR MULTIFONCTIONS

- Appareil permettant un gain de temps pour le diagnostic des systèmes électriques automobiles grâce à ses nombreuses fonctionnalités et applications.
- Test de continuité/Test de polarité.
- Mesure de la tension DC de 2V à 24V.
- Vérification des composants, moteurs électriques (lève-vitres, moteur d'essuie-glace, démarreur...) et des lampes.
- Suivi et localisation des courts-circuits.
- Détection de mauvais contacts.
- Alimentation et utilisation par raccord avec la batterie du véhicule.
- Protection contre la surintensité.
- IEC 61326/EMC/Norme CE.
- Livré avec housse de protection et notice d'utilisation.



	Poids g		EAN
E201806	548	1	3258952018063

TESTEUR VAT

- Permet de vérifier l'absence de tension sur un circuit avant de démarrer les travaux.
- Système de rangement des pointes de touche.
- Entraxe des pointes de touche de 19 mm (prise de courant).
- Test de polarité: LED + / -.
- Voltages: 6-12-24-50-120-230-400 V.
- DC / AC: 50-60 Hz.
- IP 54.
- IEC 61243-3/CAT III 600 V/Norme CE.
- 2 piles LR44 1.5V fournies.
- Livré avec notice d'utilisation.



	Poids g		EAN
E201804	176	1	3258952018049

TESTEUR DE TENSION

- Idéal pour le contrôle des circuits, fusibles, interrupteurs et le câblage sur les automobiles, remorques, bateaux, motos et autres systèmes de basse tension.
- Connectez la pince crocodile à la terre, puis tester grâce à la pointe de touche.
- Ampoule dans le manche permettant d'indiquer la présence de tension.
- 12 - 24 V.



	Poids g		EAN
E201802	220	1	3258952018025



MOTEUR

PINCES POUR COLLIERS AUTOSERRANTS

- E200504 : pince à colliers avec câble.
- E200505 : pince à colliers à 45° verrouillable et mors pivotants.
- E200506 : pince à colliers verrouillable et mors pivotants.
- E200507 : pince pour colliers Clic.
- E200508 : pince plate à extraire les durites.
- E200509 : pince à colliers standard mors pivotants fendus.
- E200510 : pince à colliers standard mors pivotants fendus en croix.

	Poids g	☒	EAN
E200504	470	1	3258952005049
E200505	240	1	3258952005056
E200506	235	1	3258952005063
E200507	230	1	3258952005070
E200508	200	1	3258952005087
E200509	245	1	3258952005094
E200510	205	1	3258952005100



JEU DE 7 PINCES POUR COLLIERS AUTOSERRANTS

- Contient les 7 pinces disponibles à l'unité : E200504-E200505-E200506-E200507-E200508-E200509-E200510.
- Livré en coffret plastique.



	Poids kg	☒	EAN
E200501	3,10	1	3258952005018

CLÉS À DOUILLE EMMANCHÉES FLEXIBLES

- Clés à douilles emmanchées 6 pans.
- Manche ergonomique bi-matière -confortable et efficace.
- Lame flexible.
- Pour le desserrage et serrage des colliers de durite.



	Dimensions	Poids g	☒	EAN
E200524	6 x 150 mm	150	1	3258952005247
E200525	7 x 150 mm	150	1	3258952005254
E200526	8 x 150 mm	160	1	3258952005261





MOTEUR

JEU DE DEUX PINCES À DURITS

- Permettent de pincer rapidement les durites sans les endommager.
- Structure en plastique.

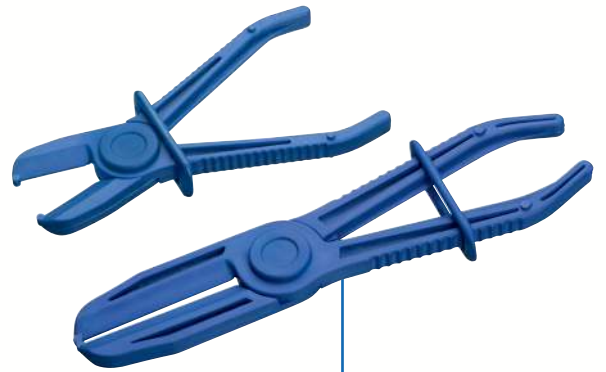

	Poids g		EAN
E201701	270	1	3258952017011

PINCE POUR DURITS DE CARBURANT

- Outil spécifique pour désaccoupler les connecteurs de filtres à carburant en ligne.
- Becs angulaires pour un meilleur accès.

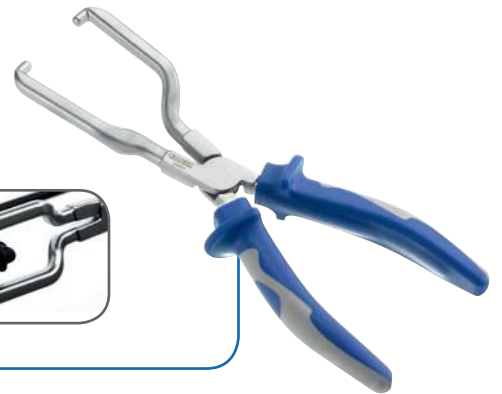

	Poids g		EAN
E200519	310	1	3258952005193

JEU DE 6 DOUILLES OUVERTES DÉPORTÉES

- Douilles 1/2" ouvertes déportées 12 - 14 - 16 - 17 - 18 - 19 mm.
- Longueur 100 mm pour atteindre les écrous d'alimentation d'injecteurs diesel dans les espaces confinés.



	Poids g		EAN
E200517	1200	1	3258952005179

OUTIL D'AMORCAGE POUR INJECTION DIESEL

- Pour amorcer les conduites de carburant diesel, les filtres et les pompes.
- Poire manuelle d'amorçage.



	Poids g		EAN
E200521	200	1	3258952005216



KIT TESTEUR DE SYSTÈME DE REFROIDISSEMENT

- Kit complet pour la détection de fuites dans les systèmes de refroidissement.
- Comprend des adaptateurs avec raccords rapides compatibles avec la majorité des voitures européennes et japonaises.
- Adaptateurs génériques permettant l'utilisation sur une large gamme de véhicules et systèmes.
- Livré en coffret plastique avec notice.



E200511	Poids kg	☒	EAN
E200511	3,9	1	3258952005117

BAC DE RÉCUPÉRATION DU LIQUIDE DE REFROIDISSEMENT

- Faible épaisseur : peut facilement se glisser sous la voiture. (4 roulettes)
- Capacité 30 litres.
- Dimensions : L.850 x l.600 x H.125 mm.



E200502	Poids kg	☒	EAN
E200502	6	1	3258952005025

JEU DE 8 PINCES D'OBTURATION POUR TUYAUX ET RACCORDS BANJOS

- Idéal pour les interventions sur les circuits de carburants, freins et climatisations.
- 2 x Banjos (deux tailles)
- 2 x 3/8"
- 2 x 1/2"
- 2 x 5/16"
- Évite l'écoulement des liquides et la contamination du circuit par des impuretés.
- 3 positions d'ouvertures réglables pour s'adapter à tout type de tuyaux et raccords.
- Livré avec embouts de rechange.

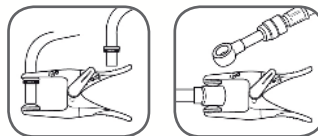

E201702	Poids g	☒	EAN
E201702	1000	1	3258952017028

PÈSE-ANTIGEL

- Permet de vérifier la qualité et la température de congélation du liquide de refroidissement du moteur.
- Test chaud et froid.
- Lecture en degrés Celsius et Fahrenheit.



E200523	Poids g	☒	EAN
E200523	200	1	3258952005230





MOTEUR

CLÉ DE SERRAGE ANGULAIRE AVEC FLEXIBLE MAGNÉTIQUE

- Carré 1/2".
- Bras flexible de 340 mm.
- Point fixe par flexible avec aimant.
- Graduation 2°.



	Poids g		EAN
E100115	257	1	3258951001158

CLÉ DE SERRAGE ANGULAIRE AVEC BARRE

- Carré 1/2".
- Tige de calage 100 mm x 50 mm
- Graduation 2°.



	Poids g		EAN
E100116	180	1	3258951001165

JEU DE 2 RODOIRS DE SOUPAPE

- Manche bois avec ventouse à chaque extrémité.
- 1 x L.245 mm avec ventouses de \varnothing 19 et 22 mm.
- 1 x L.255 mm avec ventouses de \varnothing 22 et 32 mm.



	Poids g		EAN
E200518	100	1	3258952005186

STETHOSCOPE

- Conception monobloc disposant d'un diaphragme ultra mince pour aider à localiser la source du bruit.
- Livré avec aiguille.



	Poids g		EAN
E200520	190	1	3258952005209



COFFRET POULIE D'ALTERNATEUR - 13 PIÈCES

- Pour le montage et le démontage de poulie d'alternateur.
- Douilles combinées 1/2" :
Torx®: T50.
XZN®: M10.
- Embouts 10 mm :
Torx®: T40-T50, L.75 mm.
XZN®: M8-M10, L.75 mm.
6 pans : 8-10, L.75 mm.
- Porte embouts de vissage 1/2" - 10 mm.
- 2 inserts coulissants denture multiple 33 dents.
- 1 insert coulissant hexagonal de 17 mm.
- 1 insert coulissant à 4 ergots.



E201901	Poids g	📦	EAN
E201901	1366	1	3258952019015

COFFRET POULIE D'ALTERNATEUR - 22 PIÈCES

- Kit complet pour le montage et le démontage de poulie d'alternateur.
- Douilles combinées:
Torx®: T50 1/2".
XZN®: M10 1/2" - M10 3/8".
- Douille XZN® 1/2" M10
- Embouts 10 mm:
Torx®: T40-T50, L.75 mm.
XZN®: M8-M10, L.75 mm.
6 pans : 8-10, L.75 mm.
- Porte embouts de vissage 1/2" - 10 mm.
- 3 inserts coulissants denture multiple 33 dents.
- 5 inserts coulissants hexagonaux de 17-19-21-22-27 mm.
- 2 inserts coulissants à 3 et 4 ergots.



E201902	Poids g	📦	EAN
E201902	2510	1	3258952019022

PINCE POUR SILENT-BLOCS D'ÉCHAPPEMENT

- Pince spéciale pour le démontage des silent-blocs d'échappement.
- Accès même dans les zones difficiles.
- Outil adapté à une large gamme de VL et VUL.



E200601	Poids g	📦	EAN
E200601	430	1	3258952006015





FREINS

TESTEUR DE LIQUIDE DE FREIN

- Mesure le pourcentage d'humidité du liquide de frein en rapport à la norme.
- Le testeur envoie un faible courant dans le liquide de frein et mesure sa résistance.
- 2 échelles de lecture : DOT 4 et DOT 5.1.
- Sonde de mesure extensible jusqu'à 1,5 mètre.
- Batterie : pile de 9 V type LR622 (non fournie).
- Test d'usure de la pile par diode.
- Livré en coffret plastique avec notice.



E200903	Poids g	📦	EAN
E200903	750	1	3258952009030

PURGEUR DE FREIN À DÉPRESSION

- Purgeur par dépression fonctionnant par principe Venturi.
- Pression d'utilisation 6-10 bars.
- Utilisation VL, moto.
- Utilisable pour frein ou embrayage.
- Capacité 3L.
- Manomètre indiquant la valeur de dépression.
- Embout caoutchouc : E200909.



E200901	Poids kg	📦	EAN
E200901	1	1	3258952009016

EMBOUT CAOUTCHOUC POUR PURGEUR DE FREIN

E200909	📦	EAN
E200909	1	3258952009092

BOUTEILLE DE REMPLISSAGE RÉSERVOIR

- Permet un remplissage automatique.
- Adaptation sur tous les diamètres de réservoir de liquide de frein.
- Capacité 1 L.
- Robinet de fermeture.



E200902	Poids kg	📦	EAN
E200902	0,60	1	3258952009023

SERINGUE POUR CHANGEMENT DE FLUIDES

- Capacité de 0,2 litres.
- Convient pour l'extraction et l'injections de fluides lors de l'entretien du véhicule.
- Idéal pour le liquide de freins et antigel.
- Double joint pour aspiration continue.
- Corps transparent gradué.



E200907	Poids g	📦	EAN
E200907	290	1	3258952009078



BROSSE POUR ÉTRIER DE FREINS

- Brosse métallique pour nettoyer les étriers de freins.
- Longueur : 220 mm.



E200911		EAN
1	3258952009115	

TESTEUR DE LIQUIDE DE FREINS

- Mesure le pourcentage d'humidité dans le liquide de freins.
- Lecture rapide par l'intermédiaire de LEDs.
- Compatible DOT 4.
- Livré avec une pile AAA.



E200910		EAN
1	3258952009108	

COMPOSITION POUR REPOUSSER LES PISTONS DE FREINS

- Permet de repousser les pistons en tournant à gauche ou à droite.
- Livré avec 21 adaptateurs toutes marques (liste d'application dans la notice).
- Livré en coffret plastique avec notice.



E200904	Poids kg		EAN
2,63	1	3258952009047	

COFFRET TOURNEVIS À FRAPPER - 12 PIÈCES

- Déblocage rapide des vis de disques de freins.
- 12 pièces (contenu détaillé page 129).
- Livré en boîte métallique.



E230301	Poids g		EAN
1250	1	3258952303015	

OUTILS À FORMER LES COLLETS

- Pour travailler sur tube Ø 4,75 mm.
- Forme DIN ou SAE (tube alliage cuivre).
- Conçu pour former les collets directement sur véhicule sans démontage de la tuyauterie.
- Facile d'utilisation, s'utilise avec une clé de serrage standard.
- Livré en coffret avec notice.



E200905	Poids kg		EAN
1,40	1	3258952009054	





FREINS

PIED À COULISSE POUR DISQUES DE FREINS

- Mesure l'épaisseur des disques de freins et l'usure des pneus.
- Un levier permet de libérer la mâchoire de mesure tout en gardant la cote souhaitée lorsqu'une bavure extérieure se forme sur le disque.
- Echelle métrique avec des graduations de 0,1 mm.
- Plage de mesure : 0 à 60 mm.



E200908	Poids g	📦	EAN
E200908	56	1	3258952009085

CLÉ À TUYAUTER

- Tête 6 pans : 10 x 11 mm.
- Inclignée pour faciliter l'accès aux écrous.



E200906	Poids g	📦	EAN
E200906	110	1	3258952009061

SUSPENSION

COMPRESSEUR DE RESSORT

- 3 paires de griffes équipées d'une protection plastique interchangeable pour éviter d'endommager la peinture du ressort.
- Longueur du corps : 453 mm.
- Course de compression : 300 mm.
- Puissance maximum : 10200 N (environ 1 tonne).
- 6 pans d'entraînement 24 mm.
- Livré avec accessoires d'adaptation pour ressort conique.
- Livré en coffret plastique avec notice.

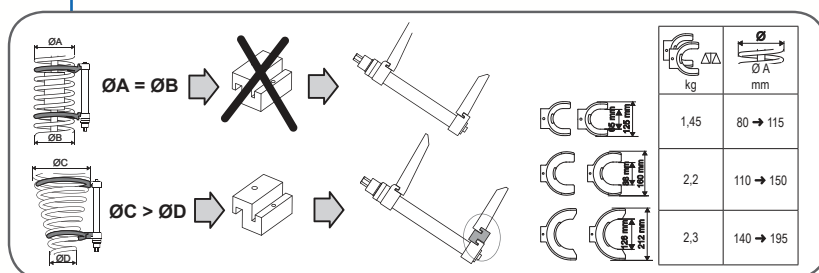

E201001	Poids kg	📦	EAN
E201001	14,30	1	3258952010012

PIÈCES DÉTACHÉES POUR COMPRESSEUR DE RESSORT

- E201002 : jeu de 3 paires de protections plastique.
- E201003 : jeu de 5 goupilles de sécurité.

E201002	📦	EAN
E201002	1	3258952010029
E201003	📦	EAN
E201003	1	3258952010036



ROUES

LEVIERS DÉMONTE-PNEUS

- E201117 : droit.
- E201118 : courbé
- Finition: phosphate.



	L mm	Poids kg		EAN
E201117	500	1.25	1	3258952011170
E201118	728	1.47	1	3258952011187

OUTIL RÉVERSIBLE DÉMONTE VALVE - OBUS

- Manche plastique adapté pour jantes aluminium.
- Longueur 285 mm.



	Poids g		EAN
E201119	80	1	3258952011194

OUTIL POUR VALVE DE ROUE

- Outil 2 en 1 :
un côté pour le démontage et le remplacement des obus de valve de roue,
un côté conique avec filet à gauche pour extraire les obus cassés.
- Convient pour les véhicules légers et motos.



	Poids g		EAN
E201109	40	1	3258952011095

DÉMONTE OBUS DE VALVE - AIR CONDITIONNÉ + ROUE

- Outil 2 en 1 :
un côté pour le démontage et le remplacement des obus de valve de roue,
un côté pour le démontage et le remplacement des obus de valve d'air conditionné.
- Convient pour les véhicules légers et motos.



	Poids g		EAN
E201110	40	1	3258952011101

PINCE À MASSE D'ÉQUILIBRAGE

- Pour fixer ou détacher les masses d'équilibrage de roues.



	Poids g		EAN
E201112	510	1	3258952011125

MODULE MOUSSE DÉDIÉ AUX TRAVAUX SUR ROUES

- Clé à chocs compacte 1/2".
- Douilles jantes alliages 17-19-21 mm.
- Démonte obus de valve 2 en 1.
- Tire valve.
- Pince à masses d'équilibrage.



	Poids g		EAN
E201125	46	1	3258952011255





ROUES

TESTEUR DE PRESSION DE PNEUS

- Affichage digital sur écran retro-éclairé.
- Unités de mesure en : PSI - Bar - Kpa - Kg/cm.
- Précision de 0,01.
- Jauge de profondeur graduée de 0 à 20 mm pour vérifier l'usure des pneus.
- Norme CE.
- Livré avec 2 piles plates LR44 1.5 V.



	Poids g		EAN
E201120	97	1	3258952011200

JEU DE 3 CLÉS DYNAMOMÉTRIQUES PRÉ-RÉGLÉES

- Couple pré-réglé pour le montage de roues.
- Dimensions : 90 N.m - 110 N.m - 120 N.m.



	Poids g		EAN
E100114	6	1	3258951001141

CLÉS EN CROIX ÉCROUS DE ROUE

- Clé adaptée au démontage des écrous de roue pour véhicules de tourisme, utilitaires et poids lourds.



		Dimensions	Poids kg		EAN
E201115	1/2"	17 x 19 x 22	1,4	1	3258952011156
E201116	3/4"	24 x 27 x 32	4,5	1	3258952011163

CLÉS ÉCROUS DE ROUES CAMION

- ISO 1711 - ISO 2725.
- Finition phosphate.



	N°	L mm	L1 mm	Poids g		EAN
E201122	27	367	215	2,5	1	3258952011224
E201123	32	372	215	2,73	1	3258952011231
E201124	33	372	215	2,73	1	3258952011248



JEU DE 3 DOUILLES HELICOÏDALES - 1/2"

- Idéal pour retirer les écrous et les boulons endommagés.
- Profil intérieur hélicoïdal.
- Deux profils par douille :
 Douille 1/2" à choc 17 mm.
 Douille 1/2" à choc 19 mm.
 Douille 1/2" à choc 21 mm.
- Adaptateur 1/2" pour douille.



E201105	Poids g	☒	EAN
	730	1	3258952011057

JEU DE 3 DOUILLES JANTES ALLIAGES 17, 19, 21 MM - 1/2"

- Protection plastique extérieure pour protéger les jantes alliages.



E194676	Quantité	Poids kg	☒	EAN
	3	0,65	1	3258951946763

DOUILLE IMPACT XZN® M18 1/2"

- XZN® M18, L.78 mm
- Pour Volkswagen et Audi et autres applications générales.



E201121	Poids g	☒	EAN
	150	1	3258952011217

JEU DE 3 EXTRACTEURS DE ROTULE DE DIRECTION

- 1 modèle pour rotule Ø 24 mm.
- 1 modèle pour rotule Ø 28 mm.
- 1 modèle pour rotule Ø 34 mm.
- Livré en coffret plastique avec notice.



E201100	Quantité	Poids kg	☒	EAN
	3	3	1	3258952011002





ROUES

KIT EXTRACTEUR DE ROULEMENT - TOUTES MARQUES

- Kit d'extraction et de montage de roulement de 1^{ère} génération (60 - 85 mm).
- Centrage et alignement précis pour ne pas endommager le roulement.
- Convient pour la plupart des modèles VW, Audi, Seat, Ford, Opel et BMW.
- Livré en coffret plastique avec notice.

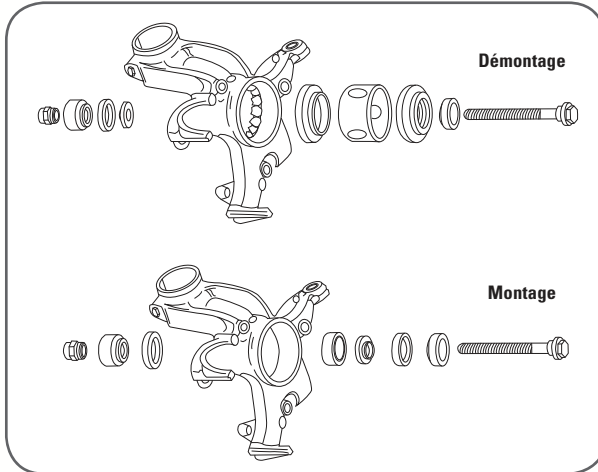

E201113	Poids kg	📦	EAN
E201113	10	1	3258952011132

KIT EXTRACTEUR DE ROULEMENT - VOITURES FRANÇAISES

- Kit d'extraction et de montage de roulement principalement dédié aux marques françaises.
- Centrage et alignement précis pour ne pas endommager le roulement.
- Convient pour la plupart des modèles Peugeot, Citroën et Renault.
- Livré en coffret plastique avec notice.

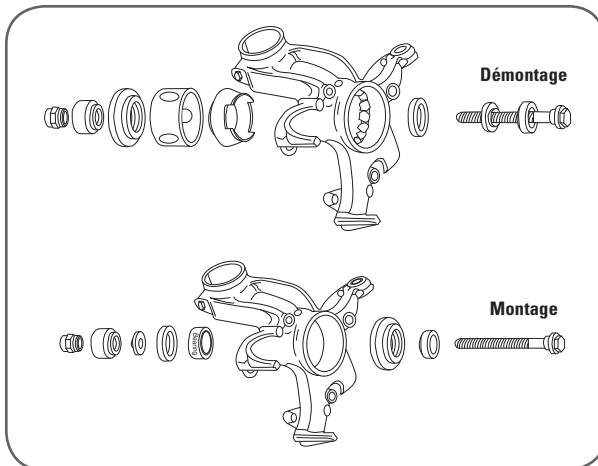

E201114	Poids kg	📦	EAN
E201114	13	1	3258952011149



CARROSSERIE

PINCE À DÉGRAFER

- Facilite l'accès pour le retrait des clips difficiles à atteindre.
- Evite d'endommager le clip.



E201201	Poids g		EAN
E201201	240	1	3258952012016

PINCE CLIP GARNITURE COURBÉE

- Facilite l'accès pour le retrait des clips difficiles à atteindre.
- Idéal pour retirer les mousses et garnitures isolantes.
- Evite d'endommager le clip.

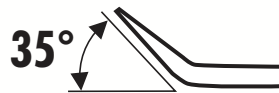

E201202	Poids g		EAN
E201202	150	1	3258952012023

JEU DE 6 OUTILS POUR LE DÉMONTAGE DE GARNITURES

- Gamme d'outils permettant de démonter ou déclipser les pièces en plastique sans les détériorer.



E201203	Poids g		EAN
E201203	285	1	3258952012030

JEU DE 4 GRATTOIRS EN PLASTIQUE

- Gamme d'outils permettant de retirer des garnitures, autocollants sur carrosserie et résidus sur jantes alliage.
- 4 largeurs : 20 - 23 - 25 - 38 mm.



E201204	Poids g		EAN
E201204	515	1	3258952012047





CARROSSERIE

COUSSIN OUVRE-PORTE GONFLABLE

- Permet l'ouverture contrôlée de la porte
- Evite les rayures et les dommages inutiles.
- Système de gonflage par poire.



E201207	Poids g		EAN
E201207	200	1	3258952015222

KIT D'OUVERTURE DE PORTES - 9 PIÈCES

- 9 outils pour ouvrir la porte d'un véhicule dont les clés sont restées à l'intérieur sans briser la glace.
- Usage strictement réservé aux professionnels.
- Livré en étui sans notice.

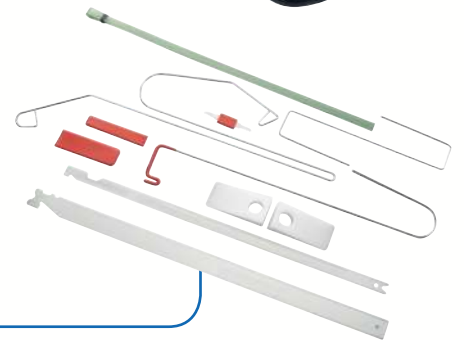

E201206	Poids g		EAN
E201206	665	1	3258952012061

MARCHE PIED

- Conception en aluminium.
- Patins antidérapant.
- Plateforme de 1 mètre de longueur.
- Pliable et léger.



E200137		EAN
E200137	1	3258952001362

CHEVALET CARROSSERIE

- Charge admissible de 226 kg.
- Patins antidérapants.
- Ouverture réglable jusqu'à 812 mm.
- Blocage de l'ouverture par chaînes.



E201211		EAN
E201211	1	3258952012115

JEU DE 12 OUTILS POUR LA MAINTENANCE D'AIRBAGS

- Jeu complet d'outils pour le démontage et l'installation d'airbags dans le véhicule.
- 5 douilles 1/4" 6 pans de 80 mm de long pour atteindre les fixations.
- 7 outils dédiés au montage et démontage d'airbags.



E201205	Poids g		EAN
E201205	810	1	3258952012054



PARE-BRISE

SUPPORT MOBILE POUR PARE-BRISE

- 4 supports en caoutchouc pour déposer facilement le pare brise sans l'endommager.
- S'utilise avec tous types de pare-brise.
- Peut servir de support pour des pièces de carrosserie types capot ou portière.
- 3 tablettes à rebords pouvant porter jusqu'à 50 kg chacune.
- 4 roues pivotantes dont deux avec freins.
- Facile et rapide à assembler.
- Livré non monté et avec notice d'assemblage.



	L mm	H mm	Poids kg	☒	EAN
E201521	770	1005	11,4	1	3258952015215

JEU DE 2 PAIRES DE VENTOUSES + SANGLE POUR PARE-BRISE

- 2 paires de ventouses de Ø 117 mm.
- Paire de ventouse capable de porter jusqu'à 40 kg.
- Sangle incluse permettant de positionner le pare-brise.



	Poids kg	☒	EAN
E201501	1,78	1	3258952015017

PAIRE DE VENTOUSES

- Paire de ventouses de Ø 117 mm.
- Capable de porter jusqu'à 40 kg.



	Poids g	☒	EAN
E201502	750	1	3258952015024

SANGLE À CLIQUET

- Utilisée avec les paires de ventouses pour le positionnement du pare-brise.



	Poids g	☒	EAN
E201503	285	1	3258952015031





PARE-BRISE

JEU DE 6 VENTOUSES DE MAINTIEN PARE BRISE

- Ventouses de Ø 78 mm.
- Indispensable pour maintenir les garnitures de carrosserie ou le pare-brise pendant les opérations de collage.
- Réglage par système de vis.



E201507	1	EAN	3258952015079
---------	---	-----	---------------

VENTOUSE À POMPE PL

- Ventouse à pompe de Ø 254 mm.
- Capable de porter jusqu'à 130 kg.
- Indicateur de fuite de vide.
- Bouton de déverrouillage rapide d'aspiration.



E201504	Poids kg	1	EAN	3258952015048
	2.53			



VENTOUSE MULTI-USAGES

- Ventouse de Ø 55 mm.
- Capable de porter jusqu'à 10 kg.
- Système de ventouse produit par serrage des 2 poignées entre elles.
- Utilisable à une main.



E201505	Poids g	📦	EAN
E201505	380	1	3258952015055

MINI VENTOUSE MULTI-USAGES

- Ventouse de Ø 23 mm.
- Capable de porter jusqu'à 5 kg.
- Idéal pour les petites vitre comme les rétroviseurs.



E201508	Poids g	📦	EAN
E201508	65	1	3258952015086

JEU DE VENTOUSES DE MAINTIEN VITRE LATÉRALE

- Ventouses de Ø 78 mm.
- Ventouses reliées par un câble gainé de 400 mm pour éviter de détériorer la peinture.
- Maintien de la fenêtre latérale pendant les travaux sur le mécanisme de vitre.
- Permet d'avoir les mains libres lors de l'utilisation.

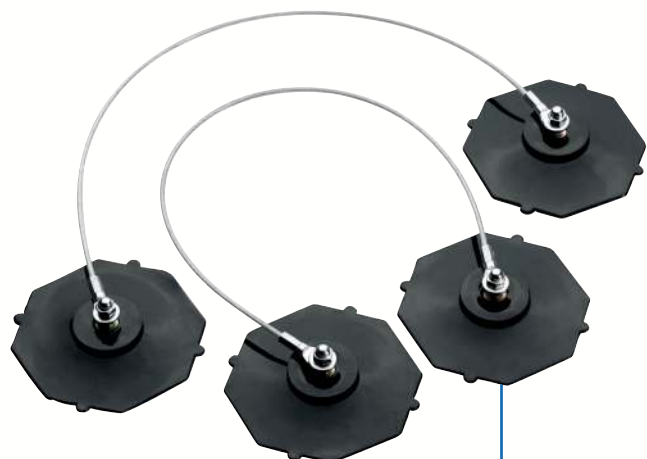

E201506	Poids g	📦	EAN
E201506	110	1	3258952015062





PARE-BRISE

JEU DE 3 OUTILS POUR CAPTEURS DE PLUIE ET DE LUMINOSITÉ

→ Jeu de 3 outils permettant de retirer facilement et sans détérioration les capteurs de pluie et de lumière sur pare-brise.

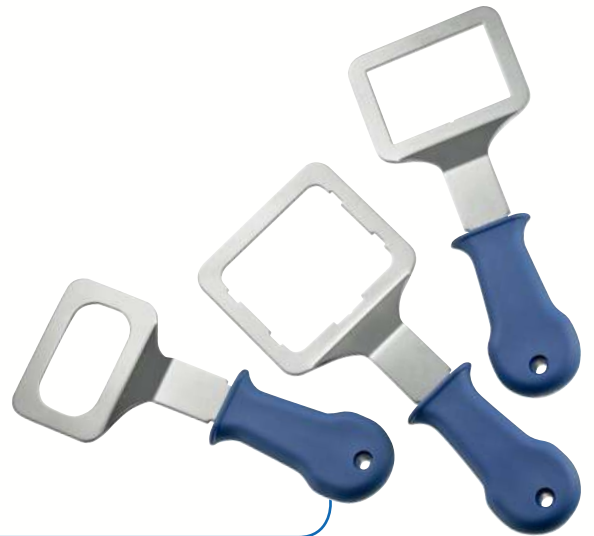

	Poids g		EAN
E201509	425	1	3258952015093

EXTRACTEUR DE BRAS D'ESSUIE-GLACES

- Pour les essuie-glaces avec ou sans gicleur intégré.
- Convient également pour l'extraction de cosses de batterie.
- Capacité de 4 KN.



	Poids g		EAN
E201512	296	1	3258952015123

EXTRACTEUR DE BRAS D'ESSUIE-GLACE

- Permet l'extraction de bras d'essuie-glace sans détérioration.
- Pour VL et VUL.
- Capacité de 2 KN.



	Poids g		EAN
E201510	140	1	3258952015109



AIGUILLE D'AMORCE

- Lame plate avec découpe en bout permettant d'insérer la corde à piano à travers le joint de pare-brise.
- Poignée plastique en T pour plus de confort et de puissance.

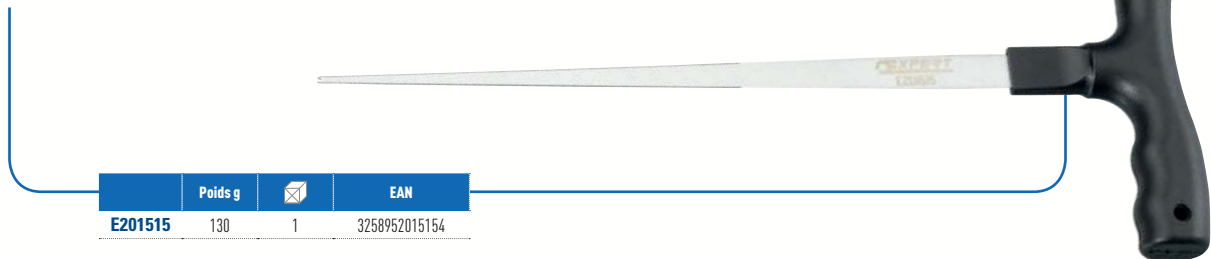

E201515	Poids g		EAN
E201515	130	1	3258952015154

2 POIGNÉES DE TIRAGE + CORDE

- Paire de poignées de tirage pour découpe de joint de pare-brise.
- Corde à piano incluse.



E201516	Poids g		EAN
E201516	360	1	3258952015161

CORDE À PIANO CARRÉE

- Corde à piano inoxydable.
- Utilisable avec les poignées de tirage E201516.
- Section carrée pour une coupe efficace et rapide.
- Longueur 5 m.

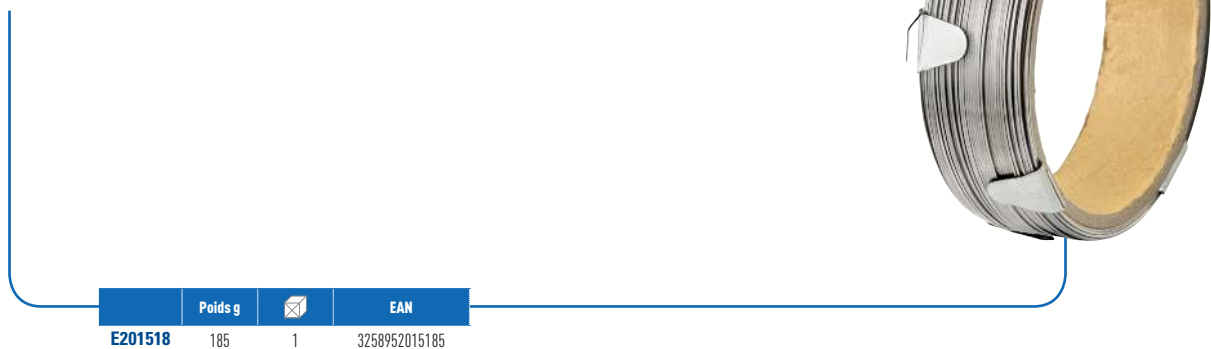

E201518	Poids g		EAN
E201518	185	1	3258952015185





PARE-BRISE

PROTECTION DE TABLEAU DE BORDS

- Permet de ne pas abimer le tableau de bord lors de la découpe du joint de pare-brise avec la corde à piano.
- Formes plates ou arrondies pour s'adapter à tous types de découpes.



	Poids g		EAN
E201522	306	1	3258952015222

COUPEAU À PARE-BRISE POUR COUPE À FROID

- Outil de coupe à froid pour joint de pare-brise.
- Lame à 90° remplaçable.
- Poignée principale pour insérer et guider la lame.
- Poignée de tirage pour appliquer une force de coupe.



	Poids g		EAN
E201513	274	1	3258952015130

LAMES DE COUPEAU

- 6 lames de rechange pour couteau E201513.



	Poids g		EAN
E201514	85	1	3258952015147



PISTOLET À SILICONE

- Idéal pour les cartouches et berlingots de colle à pare-brise.
- Tube en aluminium.
- Poignée ergonomique.



	Poids g		EAN
E090703	875	1	3258950907031

MINI GRATTOIR

- Lame rétractable.
- Changement facile des lames.
- Livré avec 3 lames.
- Possibilité de stocker 2 lames dans le compartiment arrière.



	Poids g		EAN
E201209	6	1	3258951001141

GRATTOIR

- Poignée plastique.
- Porte lame métal.
- Lames remplaçables.
- 1 lame fournie.



	Poids g		EAN
E201519	310	1	3258952015192

LAMES DE RECHANGE POUR GRATTOIR

- Pour grattoirs E201519 et E201209.
- En boîte de 5 lames.



	Poids g		EAN
E201520	12	1	3258952015208





ANIMEZ VOS POINTS DE VENTE AVEC LES SOLUTIONS DE MERCHANDISING EXPERT

1 MODULE

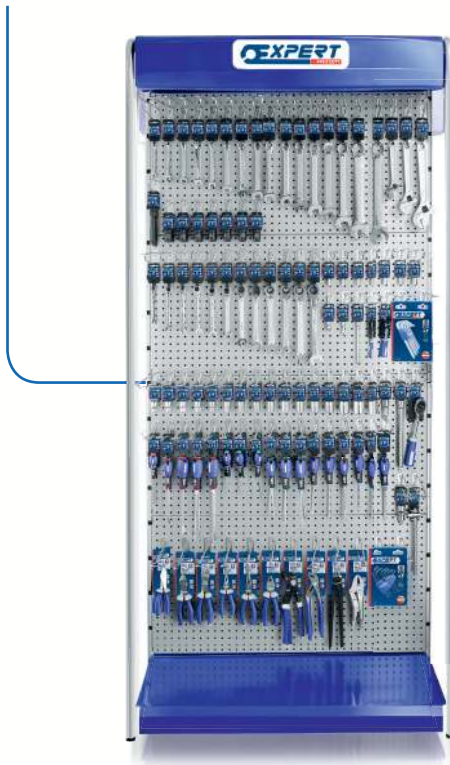

2 MODULES



3 MODULES





EXPERT PRESENTOIR 1M (30 BROCHES INCLUSES)

- 220 x 100 x 48 cm
- Tablette et lot de 30 broches inclus

E900201



TABLETTE POUR TOURNEVIS

- 23 rangées de perforations :
- 15 rangées centrales pour les dimensions les plus courantes
 - 5 rangées aux extrémités pour les lames les plus grosses
 - 3 rangées dédiées aux lames fines

E900203



TABLETTE INCLINEE

- Pour les coffrets
- Tablette inclinée, avec rebords, pour présenter les boîtes de jeux ouvertes ou fermées

E900204



10 SEPARATIONS POUR TABLETTE INCLINEE

- Pour les douilles
- Jeu de 10 séparations, à ajouter à la tablette inclinée, pour présenter les douilles et accessoires

E900205





PRÉSENTOIRS DE COMPTOIR

Livraison des produits en présentoir monté pour toute commande par unité de conditionnement.

MINI-GRATTOIR E021209

- Unité de conditionnement : 12
- Retrouvez ce produit page 263.



MIROIR TELESCOPIQUE A LEDS E051401

- Unité de conditionnement : 12
- Retrouvez ce produit page 199.



LAMPE STYLO RECHARGEABLE USB E201406

- Unité de conditionnement : 12
- Retrouvez ce produit page 199.





SIGNALÉTIQUE DE MARQUE

ORIFLAMMES

- Système de fixation : Pied piquet/croisillons rotatifs.
- Livré en sac de transport.
- E900318 : dimensions : 2,15 x 0,65 m.
- E900317 : dimensions : 3,40 x 0,65 m.



DRAPEAU E900319

- Drapeau en polyester 110g/m² avec 4 œillets.
- Dimensions : 1,80 x 1,20 m.



BANDEROLE EXTERIEURE E900320

- Bannière en vinyle 440g avec œillets et sandows.
- Dimensions : 2 x 0,6 m.



STICKERS 2 COULEURS (PACK DE 25)

- Stickers EXPERT logo blanc :
E900313 : 255 x 60 mm.
E900312 : 155 x 40 mm.
E900311 : 75 x 20 mm.
- Stickers EXPERT logo bleu :
E900316 : 255 x 60 mm.
E900315 : 155 x 40 mm.
E900314 : 75 x 20 mm.





UNE SÉLECTION D'OUTILS UNITAIRES EXPERT EST DISPONIBLE SUR CARTE, EN COMPLÉMENT DE L'OFFRE EN CONDITIONNEMENT STANDARD

CLÉS

Référence	Désignation	EAN	Unités
E113202R	CLÉ MIXTE - 6 MM	3258955132025	5
E113200R	CLÉ MIXTE - 7 MM	3258955132001	5
E113201R	CLÉ MIXTE - 8 MM	3258955132018	5
E113204R	CLÉ MIXTE - 9 MM	3258955132049	5
E113205R	CLÉ MIXTE - 10 MM	3258955132056	5
E113206R	CLÉ MIXTE - 11 MM	3258955132063	5
E113207R	CLÉ MIXTE - 12 MM	3258955132070	5
E113208R	CLÉ MIXTE - 13 MM	3258955132087	5
E113209R	CLÉ MIXTE - 14 MM	3258955132094	5
E113210R	CLÉ MIXTE - 15 MM	3258955132100	5
E113211R	CLÉ MIXTE - 16 MM	3258955132117	5
E113212R	CLÉ MIXTE - 17 MM	3258955132124	5
E113213R	CLÉ MIXTE - 18 MM	3258955132131	5
E113214R	CLÉ MIXTE - 19 MM	3258955132148	5
E113215R	CLÉ MIXTE - 20 MM	3258955132155	5
E113216R	CLÉ MIXTE - 21 MM	3258955132162	5
E113217R	CLÉ MIXTE - 22 MM	3258955132179	5
E113218R	CLÉ MIXTE - 23 MM	3258955132186	5
E113219R	CLÉ MIXTE - 24 MM	3258955132193	5
E113222R	CLÉ MIXTE - 27 MM	3258955132223	5
E113225R	CLÉ MIXTE - 30 MM	3258955132254	5
E113226R	CLÉ MIXTE - 32 MM	3258955132261	5
E117391R	CLÉ À TUYAUTER - 11x13 MM	3258955173912	5
E117392R	CLÉ A TUYAUTER - 12x14 MM	3258955173929	5
E117378R	CLÉ MIXTE À CLIQUET - 7 MM	3258955173783	5
E113301R	CLÉ MIXTE À CLIQUET - 8 MM	3258955133015	5
E113302R	CLÉ MIXTE À CLIQUET - 9 MM	3258955133022	5
E113303R	CLÉ MIXTE À CLIQUET - 10 MM	3258955133039	5
E113300R	CLÉ MIXTE À CLIQUET - 11 MM	3258955133008	5
E113304R	CLÉ MIXTE À CLIQUET - 12 MM	3258955133046	5
E113305R	CLÉ MIXTE À CLIQUET - 13 MM	3258955133053	5
E113306R	CLÉ MIXTE À CLIQUET - 14 MM	3258955133060	5
E113307R	CLÉ MIXTE À CLIQUET - 15 MM	3258955133077	5
E113308R	CLÉ MIXTE À CLIQUET - 16 MM	3258955133084	5
E113309R	CLÉ MIXTE À CLIQUET - 17 MM	3258955133091	5
E113310R	CLÉ MIXTE À CLIQUET - 18 MM	3258955133107	5
E113311R	CLÉ MIXTE À CLIQUET - 19 MM	3258955133114	5
E117370R	CLÉ MIXTE À CLIQUET - 21 MM	3258955173707	5
E117371R	CLÉ MIXTE À CLIQUET - 22 MM	3258955173714	5
E117372R	CLÉ MIXTE À CLIQUET - 24 MM	3258955173721	5



RAPPEL

Jeux de clés disponibles sur rack plastique ou en boîte carton promo
Jeux de douilles 1/4" à 1/2" disponibles sous blister



Référence	Désignation	EAN	Unités
E113370R	CLÉ À PIPE 12X6 PANS - 8 MM	3258955133701	5
E113371R	CLÉ À PIPE 12X6 PANS - 9 MM	3258955133718	5
E113372R	CLÉ À PIPE 12X6 PANS - 10 MM	3258955133725	5
E113373R	CLÉ À PIPE 12X6 PANS - 11 MM	3258955133732	5
E113374R	CLÉ À PIPE 12X6 PANS - 12 MM	3258955133749	5
E113375R	CLÉ À PIPE 12X6 PANS - 13 MM	3258955133756	5
E113376R	CLÉ À PIPE 12X6 PANS - 14 MM	3258955133763	5
E113377R	CLÉ À PIPE 12X6 PANS - 15 MM	3258955133770	5
E113378R	CLÉ À PIPE 12X6 PANS - 16 MM	3258955133787	5
E113379R	CLÉ À PIPE 12X6 PANS - 17 MM	3258955133794	5
E113380R	CLÉ À PIPE 12X6 PANS - 18 MM	3258955133800	5
E113381R	CLÉ À PIPE 12X6 PANS - 19 MM	3258955133817	5
E113383R	CLÉ À PIPE 12X6 PANS - 21 MM	3258955133831	5
E113384R	CLÉ À PIPE 12X6 PANS - 22 MM	3258955133848	5
E113386R	CLÉ À PIPE 12X6 PANS - 24 MM	3258955133862	5
E113389R	CLÉ À PIPE 12X6 PANS - 30 MM	3258955133893	5
E113390R	CLÉ À PIPE 12X6 PANS - 32 MM	3258955133909	5
E187366R	CLÉ A MOLETTE 150 MM	3258955873669	5
E187368R	CLÉ A MOLETTE 200 MM	3258955873683	5
E187470R	CLÉ A MOLETTE 250 MM	3258955874703	5
E187472R	CLÉ A MOLETTE 300 MM	3258955874727	5
E187473R	CLÉ A MOLETTE 375 MM	3258955874734	5



DOUILLES ET ACCESSOIRES

Référence	Désignation	EAN	Unités
E030601R	CLIQUET TETE RONDE 1/4"	3258955306013	5
E030602R	CLIQUET TETE ARTICULEE 1/4"	3258955306020	5
E030605R	CLIQUET PARCMETRE 1/4" A VERROUILL.	3258955306051	5
E113771R	RALLONGE 1/4" 55MM	3258955137716	5
E113756R	RALLONGE 1/4" 100MM	3258955173561	5
E113772R	RALLONGE 1/4" 150MM	3258955137723	5
E117360R	CARDAN 1/4"	3258955173608	5
E113910R	POIGNEE 1/4"	3258955139109	5
E117294R	DOUILLE 1/4" STANDARD 6 PANS 5MM	3258955172946	5
E117296R	DOUILLE 1/4" STANDARD 6 PANS 6MM	3258955172960	5
E117297R	DOUILLE 1/4" STANDARD 6 PANS 7MM	3258955172977	5
E117298R	DOUILLE 1/4" STANDARD 6 PANS 8MM	3258955172984	5
E117299R	DOUILLE 1/4" STANDARD 6 PANS 9MM	3258955172991	5
E117350R	DOUILLE 1/4" STANDARD 6 PANS 10MM	3258955173509	5
E117351R	DOUILLE 1/4" STANDARD 6 PANS 11MM	3258955173516	5
E117352R	DOUILLE 1/4" STANDARD 6 PANS 12MM	3258955173523	5
E117353R	DOUILLE 1/4" STANDARD 6 PANS 13MM	3258955173530	5
E117354R	DOUILLE 1/4" STANDARD 6 PANS 14MM	3258955173547	5
E113755R	DOUILLE 1/4" LONGUE 6 PANS 7MM	3258955137556	5
E113756R	DOUILLE 1/4" LONGUE 6 PANS 8MM	3258955137563	5
E113757R	DOUILLE 1/4" LONGUE 6 PANS 9MM	3258955137570	5
E113758R	DOUILLE 1/4" LONGUE 6 PANS 10MM	3258955137587	5
E113759R	DOUILLE 1/4" LONGUE 6 PANS 11MM	3258955137594	5
E113760R	DOUILLE 1/4" LONGUE 6 PANS 12MM	3258955137600	5
E113761R	DOUILLE 1/4" LONGUE 6 PANS 13MM	3258955137617	5
E113762R	DOUILLE 1/4" LONGUE 6 PANS 14MM	3258955137624	5





DOUILLES ET ACCESSOIRES

Référence	Désignation	EAN	Unités
E031702R	CLIQUET MANCHE ARTICULE 3/8"	3258955317026	5
E031706R	CLIQUET PARCMETRE 3/8" A VERROUILL.	3258955317064	5
E113850R	RALLONGE 3/8" 125MM	3258955138508	5
E117367R	CARDAN 3/8"	3258955173677	5
E030939R	DOUILLE 3/8" 6 PANS - 10 mm	3258955309397	5
E030940R	DOUILLE 3/8" 6 PANS - 11 mm	3258955309403	5
E030941R	DOUILLE 3/8" 6 PANS - 12 mm	3258955309410	5
E030942R	DOUILLE 3/8" 6 PANS - 13 mm	3258955309427	5
E030943R	DOUILLE 3/8" 6 PANS - 14 mm	3258955309434	5
E030944R	DOUILLE 3/8" 6 PANS - 15 mm	3258955309441	5
E030945R	DOUILLE 3/8" 6 PANS - 16 mm	3258955309458	5
E030946R	DOUILLE 3/8" 6 PANS - 17 mm	3258955309465	5
E030947R	DOUILLE 3/8" 6 PANS - 18 mm	3258955309472	5
E030948R	DOUILLE 3/8" 6 PANS - 19 mm	3258955309489	5
E032801R	CLIQUET TETE RONDE 1/2"	3258955328015	5
E032802R	CLIQUET TETE ARTICULEE 1/2"	3258955328022	5
E032803R	CLIQUET MANCHE ARTICULE 1/2"	3258955328039	5
E032805R	MANCHE 1/2" ARTICULE 600MM	3258955328053	5
E032808R	CLIQUET PARCMETRE 1/2" A VERROUILL.	3258955328084	5
E117259R	POIGNEE EN T 1/2"	3258955172595	5
E113710R	RALLONGE 1/2" 75 MM	3258955137105	5
E117260R	RALLONGE 1/2" 130 MM	3258955172601	5
E117261R	RALLONGE 1/2" 250 MM	3258955172618	5
E117264R	CARDAN 1/2"	3258955172649	5
E117086R	DOUILLE 1/2" STANDARD 6 PANS 8MM	3258955170867	5
E117088R	DOUILLE 1/2" STANDARD 6 PANS 10MM	3258955170881	5
E117089R	DOUILLE 1/2" STANDARD 6 PANS 11MM	3258955170898	5
E117090R	DOUILLE 1/2" STANDARD 6 PANS 12MM	3258955170904	5
E117091R	DOUILLE 1/2" STANDARD 6 PANS 13MM	3258955170911	5
E117092R	DOUILLE 1/2" STANDARD 6 PANS 14MM	3258955170928	5
E117093R	DOUILLE 1/2" STANDARD 6 PANS 15MM	3258955170935	5
E117094R	DOUILLE 1/2" STANDARD 6 PANS 16MM	3258955170942	5
E117095R	DOUILLE 1/2" STANDARD 6 PANS 17MM	3258955170959	5
E117096R	DOUILLE 1/2" STANDARD 6 PANS 18MM	3258955170966	5
E117097R	DOUILLE 1/2" STANDARD 6 PANS 19MM	3258955170973	5
E117098R	DOUILLE 1/2" STANDARD 6 PANS 20MM	3258955170980	5
E117099R	DOUILLE 1/2" STANDARD 6 PANS 21MM	3258955170997	5
E117250R	DOUILLE 1/2" STANDARD 6 PANS 22MM	3258955172502	5
E117251R	DOUILLE 1/2" STANDARD 6 PANS 23MM	3258955172519	5
E117252R	DOUILLE 1/2" STANDARD 6 PANS 24MM	3258955172526	5
E117253R	DOUILLE 1/2" STANDARD 6 PANS 26MM	3258955172533	5
E117254R	DOUILLE 1/2" STANDARD 6 PANS 27MM	3258955172540	5
E117255R	DOUILLE 1/2" STANDARD 6 PANS 28MM	3258955172557	5
E117256R	DOUILLE 1/2" STANDARD 6 PANS 29MM	3258955172564	5
E117257R	DOUILLE 1/2" STANDARD 6 PANS 30MM	3258955172571	5
E117258R	DOUILLE 1/2" STANDARD 6 PANS 32MM	3258955172588	5
E117265R	DOUILLE 1/2" LONGUE 6 PANS 12MM	3258955172656	5
E117266R	DOUILLE 1/2" LONGUE 6 PANS 13MM	3258955172663	5
E117267R	DOUILLE 1/2" LONGUE 6 PANS 14MM	3258955172670	5
E117268R	DOUILLE 1/2" LONGUE 6 PANS 15MM	3258955172687	5
E117269R	DOUILLE 1/2" LONGUE 6 PANS 16MM	3258955172694	5
E117270R	DOUILLE 1/2" LONGUE 6 PANS 17MM	3258955172700	5
E117271R	DOUILLE 1/2" LONGUE 6 PANS 18MM	3258955172717	5
E117272R	DOUILLE 1/2" LONGUE 6 PANS 19MM	3258955172724	5





VISSAGE

Référence	Désignation	EAN	Unités
E113976R	JEU DE 9 CLÉS MÂLES LONGUES TÊTE SPH	3258955139765	5
E121102R	JEU DE 7 CLÉS TORX	3258955211027	5
E164983R	TOURNEVIS FENTE ELECTRICIEN 3,5X75	3258955649837	5
E165017R	TOURNEVIS FENTE ELECTRICIEN 4X100	3258955650178	5
E165476R	TOURNEVIS FENTE ELECTRICIEN 5,5X125	3258955654763	5
E165141R	TOURNEVIS FENTE MECANICIEN 6,5X150	3258955651410	5
E165138R	TOURNEVIS FENTE MECANICIEN 8X175	3258955651380	5
E160202R	TOURNEVIS FENTE MECANICIEN ECROU 6,5X150	3258955602023	5
E160203R	TOURNEVIS FENTE MECANICIEN ECROU 8X175	3258955602030	5
E160204R	TOURNEVIS FENTE MECANICIEN ECROU 10X200	3258955602047	5
E160505R	TOURNEVIS TORX T10X75	3258955605055	5
E160506R	TOURNEVIS TORX T15X75	3258955605062	5
E160507R	TOURNEVIS TORX T20X100	3258955605079	5
E160508R	TOURNEVIS TORX T25X100	3258955605086	5
E160509R	TOURNEVIS TORX T27X100	3258955605093	5
E160510R	TOURNEVIS TORX T30X125	3258955605109	5
E160511R	TOURNEVIS TORX T40X125	3258955605116	5
E165207R	TOURNEVIS PH1X100	3258955652073	5
E165209R	TOURNEVIS PH2X125	3258955652097	5
E160301R	TOURNEVIS PH2X125 ECROU	3258955603013	5
E165335R	TOURNEVIS PZ1X100	3258955653353	5
E165337R	TOURNEVIS PZZX125	3258955653377	5
E160401R	TOURNEVIS PZZX125 ECROU	3258955604010	5



RAPPEL

Tous les jeux de tournevis sont sous blister ou en boîte carton promo
 Les tournevis à cliquet sont sous blister
 50 refs d'embouts, par lot, sont en boîte plastique transparent.





DOUILLES IMPACT

Référence	Désignation	EAN	Unités
E113494R	DOUILLE IMPACT 1/2" 6 PANS 14MM	3258955134944	5
E113495R	DOUILLE IMPACT 1/2" 6 PANS 15MM	3258955134951	5
E113496R	DOUILLE IMPACT 1/2" 6 PANS 16MM	3258955134968	5
E113497R	DOUILLE IMPACT 1/2" 6 PANS 17MM	3258955134975	5
E113498R	DOUILLE IMPACT 1/2" 6 PANS 18MM	3258955134982	5
E113499R	DOUILLE IMPACT 1/2" 6 PANS 19MM	3258955134999	5
E113588R	DOUILLE IMPACT 1/2" 6 PANS 21MM	3258955135880	5
E113589R	DOUILLE IMPACT 1/2" 6 PANS 22MM	3258955135897	5
E113592R	DOUILLE IMPACT 1/2" 6 PANS 24MM	3258955135927	5
E113594R	DOUILLE IMPACT 1/2" 6 PANS 27MM	3258955135941	5
E113596R	DOUILLE IMPACT 1/2" 6 PANS 30MM	3258955135965	5
E113617R	RALLONGE IMPACT 1/2" 125MM	3258955136177	5



PINCES

Référence	Désignation	EAN	Unités
E080205R	PINCE COUPANTE DIAGONALE MECANICIEN 160MM	3258955802058	5
E080206R	PINCE COUPANTE DIAGONALE MECANICIEN 180MM	3258955802065	5
E080209R	PINCE COUPANTE DIAGONALE ELECTRICIEN 160MM	3258955802096	5
E080407R	PINCE BECS 1/2 RONDS DROITS 160MM	3258955804076	5
E080408R	PINCE BECS 1/2 RONDS DROITS 200MM	3258955804083	5
E080409R	PINCE BECS LONGS COUDES 160MM	3258955804090	5
E080410R	PINCE BECS LONGS COUDES 200MM	3258955804106	5
E080503R	PINCE UNIVERSELLE 160MM	3258955805035	5
E080504R	PINCE UNIVERSELLE 180MM	3258955805042	5
E050106R	PINCE A DENUDER 170MM	3258955501067	5
E050415R	PINCE MULTIPRISE 1000 VOLTS 250MM	3258955504150	5
E184690R	PINCE MULTIPRISE GAINÉES PVC 240 MM	3258955846908	5
E084648R	PINCE MULTIPRISE ENTREPASSEE 250 MM	3258955846489	5
E050406R	PINCE COUPANTE DIAGONALE 1000 VOLTS 160MM	3258955504068	5
E050408R	PINCE BECS 1/2 RONDS DROITS 1000 VOLTS 160MM	3258955504082	5
E050410R	PINCE BECS LONGS COUDES 1000 VOLTS 160MM	3258955804105	5
E050412R	PINCE UNIVERSELLE 1000 VOLTS 160MM	3258955504129	5
E050413R	PINCE UNIVERSELLE 1000 VOLTS 180MM	3258955504136	5
E050416R	PINCE A DENUDER 1000 VOLTS 170MM	3258955504167	5
E084808R	PINCE-ETAU BECS COURTS 185 MM	3258955848087	5
E080701R	PINCE-ETAU 250MM	3258955807015	5
E084648R	PINCE MULTIPRISE ENTREPASSEE 250 MM	3258955846489	5
E084808R	PINCE -ETAU MONO REGLAGE BECS COURTS	3258955848087	5
E117903R	PINCE A SERTIR STANDARD	3258955179037	5
E184182R	TENAILLES RUSSE 280 MM	3258955841828	5



RAPPEL

Tous les jeux de pinces sont sur carte.



FRAPPE

Référence	Désignation	EAN	Unités
E150102R	MARTEAU DIN DE 30MM	3258955501029	5
E150103R	MARTEAU DIN DE 50MM	3258955501036	5
E150104R	MARTEAU DIN DE 80MM	3258955501043	5
E154668R	RIVOIRS - BOIS 32 MM	3258955546686	5
E154670R	RIVOIRS - BOIS 40 MM	3258955546709	5
E154674R	RIVOIRS - BOIS 55 MM	3258955546747	5
E150302R	MASSETTE A EMBOUTS D32 MM	3258955503023	5



AUTRES

Référence	Désignation	EAN	Unités
E020902R	CISAILLE AVIATION COUPE A DRTE CONF	3258955209024	5
E020903R	CISAILLE AVIATION COUPE A GCHE CONF	3258955209031	5
E117821R	CLÉ SERRE TUBE 10"	3258955178214	5
E117822R	CLÉ SERRE TUBE 14"	3258955178221	5



RAPPEL

Les packagings de nombreux autres produits du catalogue sont naturellement destinés à une présentation sur les points de vente.

Quelques exemples :

- Les boîtes de douilles et d'embouts en fourreau
- La plupart des produits auto en coffret, sur carte, ou sous blister
- La baladeuse et la pince à sertir sous blister...



BOULONNERIE 6 PANS

Clés de serrage à ouverture fixe clés à douilles 	VIS MÉTRIQUES (Ø des vis en mm)		ÉCROUS MÉTRIQUES (Ø des vis en mm)	
	NF EN ISO 4018	NF EN ISO 4014	NF EN ISO 4035	NF EN ISO 4032
3,2		1,6	1,6	1,6
4		2	2	2
4,5		2,3	2,2+2,3	2,2+2,3
5		2,5+2,6	2,5+2,6	2,5+2,6
5,5		3	3	3
6		3,5	3,5	
7		4	4	4
8	5	5	5	5
9				
10	6	6	6	6
11	7	7	7	7
12				
13	8	8	8	8
14				
15				
16	(10)	(10)	(10)	
17	10	10	10	10
18	(12)	(12)	(12)	(12)
19	12	12	12	12
20				
21	(14)	(14)	(14)	(14)
22	14	14	14	14
23				
24	16	16	16	16
25				
26				
27	18	18	18	18
28				
29				
30	20	20	20	20
32	22	22	22	22

(): ISO 691

VIS A FENTE



CONFORME AUX NORMES : NF - E74352 / ISO 2380 - 1 / DIN 5263

A x B	VIS MÉTRIQUES (Ø des vis en mm)					VIS A TÔLE (Ø des vis en mm)			VIS A BOIS (Ø des vis en mm)		
	Tête fraisée	Fraisée bombée	Cylindrique	Cylindrique large	Sans tête	Tête fraisée	Fraisée bombée	Cylindrique	Tête fraisée	Tête bombée	Tête ronde
	NF EN ISO 2009	NF EN ISO 2010	NF EN ISO 1207	NF EN ISO 1580	NF EN 24766	NF EN ISO 1482	NF EN ISO 1483	NF E 1481	NF E 25-604	NF E 25-605	NF E 25-606
0,4 x 2	1,6				2,5+3				1,6		1,6
0,4 x 2,5		1,6	1,6+1,8	1,6	3,5					1,6	2
*0,5 x 3	2	2	2	2	4	2,2	2,2	2,2	2,2	2	
0,6 x 4			2				2,2				
0,6 x 3,5	2,5	2,5	2,5	2,5				2,2	2,5	2,5	2,5
*0,6 x 4,5		2,5	2,5				2,2			2,5	
0,8 x 4	3	3	3	3+3,5	5	2,9	2,9	2,9	3	3	3
*0,8 x 5,5	3,5	3,5	3	3+3,5							3,5
1 x 5,5	3,5+4	3,5+4	3,5	4		3,5/3,9	3,5/3,9	3,5+3,9	4+4,5	4+4,5	4+4,5
1,2 x 6,5	4+5	4+5	4		8	4,2+4,8	4,2+4,8		5	5	5+5,5
1,2 x 8		5	5			4,8	4,2+4,8	5,5	5,5		
1,6 x 8	6	6			10+12	5,5+6,3	5,5+6,3		6	6	6
1,6 x 10		6	6	14		6,3	5,5+6,3	7+8	7		
2 x 12	8	8	8	8	16	8	8	8		8	7+8

* Pour visseuses seulement

EMPREINTES PHILLIPS® - POZIDRIV®



PH	PZ	VIS MÉTRIQUES (Ø des vis en mm)		VIS A TÔLE (Ø des vis en mm)			VIS A BOIS (Ø des vis en mm)			
		Fraisée et fraisée bombée	Cylindrique	Cylindrique	Tête fraisée	Fraisée bombée	Fraisée bombée	Ronde	Tête fraisée	
		NF EN ISO 7044-1 NF EN ISO 7046-2 NF EN ISO 7047	NF EN ISO 7045	NF EN ISO 7049	NF EN ISO 7050	NF EN ISO 7051	NF E 25-602	NF E 25-603	NF E 25-601	
*00										
0	0	1,6	1,6	(2,2)	(2,2)	(2,2)	2	2	2	
		2	1,8							
1	1	2,5	2	2,2	2,2	2,2	2,5	2,5	2,5	
		3	2,5+3	2,9	2,9	2,5+2,9	3	3	3	
		3,5	3,5	3,5	3,5	3,5	3,5	3,5	3,5	
2	2	4	4	4,2	4,2	4,2	4+4,5	4+4,5	4+4,5	
		5	5	4,8	4,8	4,8	5	5	5	
							5,5	5,5	5,5	
3	3	6	6	5,5	5,5	5,5	6	6	6	
				6,3	6,3	6,3	7	7	7	
4	4	8	8	8	8	8	8	8	8	
		10	10	9,5	9,5	9,5				

*VIS SPECIALES

EMPREINTES TORX®



		VIS METRIQUES (Ø des vis en mm)				VIS A TÔLE (Ø des vis en mm)		
		Cylindrique	Fraisée	Fraisée bombée	Cylindrique bombée	Cylindrique	Fraisée	Fraisée bombée
		NF EN ISO 14583	NF E 25-107	NF EN ISO 14584	NF EN ISO 14579	NF EN ISO 14585	NF EN ISO 14586	NF EN ISO 14587
T6	1,65	X	X	X	X	X	X	X
T7	1,97	X	X	X	X	X	X	X
T8	2,30	2,5	2,5	2,5	2,5	2,9	2,9	2,9
T9	2,48					2,9		
T10	2,72	3	3	3	3	3,5	3,5	3,5
T15	3,26		3,5	3,5	3,5	3,9	3,9	3,9
T20	3,84	4	4	4	4	4,2	4,2	4,2
T25	4,40	5	5	5	5	4,8+5,5	4,8+5,5	4,8+5,5
T27	4,96	XX	XX	XX	XX	XX	XX	XX
T30	5,49	6	6	6	6	6,3	6,3	6,3
T40	6,60	8	8	8	8			
T45	7,77	XXX	XXX	XXX	XXX	XXX	XXX	XXX
T50	8,79	10	10	10	10			

VIS SPECIALES : X : 1,6 - 2

XX : 4,5 - 5 - 6 XXX : 8 - 10

CLÉS MÂLES - VIS 6 PANS CREUX



		VIS METRIQUES (Ø des vis en mm)				
		Cylindrique	Tête fraisée	Sans tête	Sans tête pointeau	Sans tête à téton
		NF EN ISO 4762	NF EN ISO 10642	NF EN ISO 4026 / NF EN ISO 4029	NF EN ISO 4027	NF EN ISO 4028
0,9				2	2	2
1,3	1,4			2,5	2,5	2,5
1,5	1,6+2			3	3	3
2	2,5	3		4	4	4
2,5	3	4		5	5	5
3	4	5		6	6	6
4	5	6		8	8	8
5	6	8		10	10	10
6	8	10		12+14	12+14	12+14
7						
8	10	12		16	16	16
10	12	14+16		18+20	18+20	18+20
12	14	18+20		22+24	22+24	22+24
14	16+18	22+24				
17	20+22					
19	24+27					
22	30					
24	33					

A

ADAPTATEUR MAGNÉTIQUE 1/2" - 3/4"	88
ADAPTATEUR MAGNÉTIQUE 1/4" - 3/8"	60
ADAPTATEUR MAGNÉTIQUE 3/8" - 1/2"	71
AIGUILLE D'AMORCE	261
AUGMENTATEUR 1/2" - 3/4"	88
AUGMENTATEUR 1/4" - 3/8"	60
AUGMENTATEUR 3/4" - 1"	98
AUGMENTATEUR 3/8" - 1/2"	72

B

BAC DE RÉCUPÉRATION DU LIQUIDE DE REFROIDISSEMENT	245
BAC DE RÉCUPÉRATION ET STOCKAGE	
D'HUILE DE VIDANGE	232
BAC RÉCUPÉRATEUR D'HUILE DE VIDANGE	232
BANDEROLE EXTERIEURE	267
BOITE À OUTIL TEXTILE	17
BOITES À OUTILS	16
BOÎTES MÉTALLIQUES	16
BOÎTES PLASTIQUE	16
BOOSTER 12 V	239
BOUTEILLE DE REMPLISSAGE RÉSERVOIR	248
BROCHES	42
BROSSE MÉTALLIQUE	238
BRUCELLES	223
BURETTES	207
BURINS	183

C

CALES D'ÉPAISSEUR	237
CARDAN 1/2"	89
CARDAN 1/4"	89
CARDAN 3/8"	72
CARDAN IMPACT 1/2"	151
CARDAN IMPACT 3/4"	154
CARDANS 3/4"	98
CHAINES 1/2" POUR FILTRE À HUILE	235
CHANDELLES À CRÉMAILLÈRE	228
CHARIOT DE VISITE	229
CHARIOTS D'ATELIER	14
CHASSE-GOUPILLES	182
CISAILLE CHANTOURNEUSE	191
CISAILLE COUPE-TOUT	193
CISAILLES	190
CISAILLES À TÔLE	191
CISAILLES AVIATION	190
CISAILLES AVIATION COUPE-DROITE	190
CISAILLES DÉMULTIPLIÉES CHANTOURNEUSES	190
CISEAUX	193
CISEAUX BI-MATIÈRE	221
CISEAUX ÉLECTRICIEN	221
CLÉ "COIFFE" AUTO-SERRANTE UNIVERSELLE	236
CLÉ À CHÂÎNE	210
CLÉ À ÉCHAFAUDAGE 19MM	45
CLÉ À TUYAUTER CONTRECROUDÉE	250
CLÉS "COIFFES" POUR FILTRES À HUILE	236
CLÉS À CHOCS 1"	144
CLÉS À CHOCS 1/2"	142
CLÉS À CHOCS 3/4"	143
CLÉS À CLIQUET "4 EN 1"	32
CLÉS À DOUILLE EMMANCHÉES FLEXIBLES	243
CLÉS À DOUILLE EMMANCHÉES MÉTRIQUES	116
CLÉS À ÉCHAFAUDAGE	45-205
CLÉS À ERGOTS	45
CLÉS À FOURCHES	34
CLÉS À FOURCHES DIN	36
CLÉS À MOLETTE	43
CLÉS À PIPE DÉBOUCHÉES	39
CLÉS À SANGLE	210

CLÉS À TUYAUTER	42
CLÉS DE SERRAGE ANGULAIRE	246
CLÉS DE VIDANGE	233
CLÉS DYNAMOMÉTRIQUES	138
CLÉS ÉCROUS DE ROUES CAMION	252
CLÉS EN CROIX ÉCROUS DE ROUE	252
CLÉS EN TUBE COUDÉES 6X6 PANS	40
CLÉS EN TUBE DROITE 6X6 PANS	41
CLÉS MÂLES 6 PANS	118
CLÉS MÂLES EN T	126
CLÉS MÂLES EN T EMMANCHÉES	123
CLÉS MÂLES RESISTORX®	122
CLÉS MÂLES TORX®	122
CLÉS MIXTES	22
CLÉS MIXTES À CLIQUET	28
CLÉS MIXTES À CLIQUET ARTICULÉES	30
CLÉS MIXTES À CLIQUET COURTES	31
CLÉS MIXTES À CLIQUET RAPIDES	29
CLÉS MIXTES CONTRECROUDÉES	27
CLÉS MIXTES COURTES	25
CLÉS MIXTES LONGUES	26
CLÉS POLYGONALES À CLIQUET	32
CLÉS POLYGONALES CONTRECROUDÉES	37
CLÉS RÉGLABLES POUR FILTRE À HUILE	235
CLÉS SERRE TUBES	209
CLÉS SERRE TUBES EN ALUMINIUM	208
CLÉS SERRE TUBES TYPE SUÉDOISE	208
CLÉS UNIVERSELLES À SANGLE	210
CLIQUET 1"	100
CLIQUETS 1/2"	84
CLIQUETS 1/4"	58
CLIQUETS 3/4"	95
CLIQUETS 3/8"	68
CLIQUETS PNEUMATIQUES	146
COFFRE ROULANT	9
COFFRES DE CHANTIER	15
COFFRET D'EMBOUS 1/4"	128
COFFRET DE 6 DOUILLES "COIFFES" EN ALUMINIUM	236
COFFRET DE TOURNEVIS MULTILAMES DE PRÉCISION	222
COFFRET DE VISSAGE 1/4" AVEC TOURNEVIS REVOLVER	133
COFFRET TOURNEVIS À FRAPPER	127-249
COFFRETS DE DOUILLES 1"	100
COFFRETS DE DOUILLES 1/2"	78
COFFRETS DE DOUILLES 1/4"	54
COFFRETS DE DOUILLES 3/4"	95
COFFRETS DE DOUILLES 3/8"	66
COFFRETS DE DOUILLES IMPACT 1/2"	148
COFFRETS DE DOUILLES MULTI-CARRÉS	50
COFFRETS POULIE D'ALTERNATEUR	247
COMPOSITION POUR REPOUSSER LES PISTONS DE FREINS	249
COMPOSITIONS MULTI OUTILS	18
COMPRESSEUR DE RESSORT	250
CORDE À PIANO CARRÉE	261
COUPE TUBE CUIVRE	210
COUPE VERRE	206
COUPE-BOULONS BRAS TUBULAIRES	189
COUPE-CÂBLES CUIVRE	164-214
COUPE-TOUT	193
COUSSIN OUVRE-PORTE GONFLABLE	256
COUTEAU À PARE-BRISE	262
COUTEAU DE SÉCURITÉ	193
COUTEAUX	220
CRIC	228
CUTTERS	192

D

DÉMONTE OBUS DE VALVE	251
DOIGT MAGNÉTIQUE FLEXIBLE	231
DOUILLE IMPACT 1/2" PORTE-EMBOUS 5/16"	151
DOUILLE IMPACT XZN® M18 1/2"	253

DOUILLE PORTE-EMBOUS 1/4"	60
DOUILLE 3/8" PORTE-EMBOUS 1/4"	71
DOUILLES 1"	101
DOUILLES 1/2"	89
DOUILLES 1/4"	61
DOUILLES 3/4"	99
DOUILLES 3/8"	72
DOUILLES À BOUGIE	237
DOUILLES À CHOC HELICOÏDALES	253
DOUILLES FUSIBLES	139
DOUILLES IMPACT 1/2"	151
DOUILLES IMPACT 1"	157
DOUILLES IMPACT 3/4"	155
DOUILLES IMPACT 3/8"	148
DOUILLES JANTES ALLIAGES	253
DOUILLES MAGNÉTIQUES POUR VIS 6 PANS	132
DOUILLES OUVERTES DÉPORTÉES	244
DOUILLES TORX® 1/2"	92
DOUILLES TORX® 1/4"	64
DOUILLES TORX® 3/8"	75
DOUILLES TOURNEVIS 1/2"	93
DOUILLES TOURNEVIS 1/4"	64
DOUILLES TOURNEVIS 3/8"	75
DOUILLES TOURNEVIS IMPACT 1/2"	153
DRAPEAU	267

E

EMBOU CAOUTCHOUC POUR PURGEUR DE FREIN	248
EMBOU DE VIDANGE 3/8"	234
EMBOUS 1/4"	130
EMBOUS DE VISSAGE	130
EMBOUS INTERCHANGEABLES NYLON	181
ENTONNOIR À HUILE	233
ENTONNOIR À ROBINET	233
ETABLIS	13
ETAUX	205
EXTRACTEUR DE COSES DE BATTERIE	239
EXTRACTEUR 2 GRIFFES	211
EXTRACTEUR DE BOBINES D'ALLUMAGE VAG	238
EXTRACTEUR DE BRAS D'ESSUIE-GLACES	260
EXTRACTEUR DE FLUIDES	230
EXTRACTEUR DE ROTULE DE DIRECTION	253
EXTRACTEURS DE ROULEMENT	254

F

FER À SOUDER	221
--------------------	-----

G

GRATTOIRS	204-263
GRIFFE FLEXIBLE MAGNÉTIQUE À LED	199-231
GRIFFES POUR EXTRACTEUR	211

J

JEU DE 3 ADAPTATEURS MAGNÉTIQUES	52
JEU DE PINCES	160
JEU DE TOURNEVIS DE PRÉCISION	222
JEUX DE CLÉS MÂLES	117
JEUX DE CLÉS MÂLES EN T	126
JEUX DE CLÉS MÂLES EN T EMMANCHÉES	123
JEUX DE DOUILLES 1/2"	78
JEUX DE DOUILLES 1/4"	56
JEUX DE DOUILLES 3/8"	67
JEUX DE DOUILLES IMPACT 1"	156
JEUX DE DOUILLES IMPACT 1/2"	150
JEUX DE DOUILLES IMPACT 3/8"	148
JEUX DE DOUILLES MULTI-CARRÉS	51
JEUX DE DOUILLES TOURNEVIS	64
JEUX DE TOURNEVIS	104

JEUX DE TOURNEVIS ISOLÉS 1000 VOLTS	218
JEUX DE TOURNEVIS	112
JONCS ET BAGUES POUR DOUILLES IMPACT 1"	157
JONCS ET BAGUES POUR DOUILLES IMPACT 1/2"	151
JONCS ET BAGUES POUR DOUILLES IMPACT 3/4"	154

K

KIT D'OUVERTURE DE PORTES	256
KIT DE RÉPARATION POUR BOUGIE D'ALLUMAGE	238
KIT DE RÉPARATION POUR CARTERS D'HUILE	233
KIT SERRURE + CLÉS	12
KIT TESTEUR DE SYSTÈME DE REFRROIDISSEMENT	245
KITS DE RÉPARATION DE CLIQUETS	139

L

LAME DE RECHANGE	215
LAMES DE COUTEAU	262
LAMES DE CUTTERS	192
LAMES DE RECHANGE POUR GRATTOIR	204-263
LAMES DE SCIE	186
LAMES POUR COUPE-BOULONS	189
LAMPE "POCKET" À LED 2W	198
LAMPE D'INSPECTION	198
LAMPE STYLO	198
LAMPES FLEXIBLES	201
LEVIERS D'EFFORT	205-230
LEVIERS DÉMONTÉ-PNEUS	251
LIMES	188

M

MAILLETS	181
MANCHE POUR CLIQUET 3/4"	96
MARTEAUX	178
MASSES	180
MASSETTES	181
MERCHANDISING	264
MÈTRES À RUBAN BI-MATIÈRE	173
MEULEUSES	145
MEULE D'ÉBAVURAGE	145
MINI GRATTOIR	263
MINI LAMPE MAGNÉTIQUE	200
MINI LAMPE FLEXIBLE À LEDS À EMBASE MAGNÉTIQUE	201
MINI PORTE-EMBOUTS À CLIQUET 1/4"	132
MINI SCIE	186
MINI TOURNEVIS PLAT	116
MINI TOURNEVIS PORTE-EMBOUTS À CLIQUET	134
MINI VENTOUSE MULTI-USAGES	259
MIROIRS TÉLÉSCOPIQUES	231
MODULES	11
MOUSSE REPOSE GENOUX	206-229
MULTIMÈTRES	241
MULTIPLICATEURS DE COUPLE	139

N

NIVEAUX MAGNÉTIQUES	173
---------------------------	-----

O

ORIFLAMMES	267
OUTIL À DÉGAINER	215
OUTIL D'AMORÇAGE POUR INJECTION DIESEL	244
OUTIL POUR VALVE DE ROUE	251
OUTIL RÉVERSIBLE DÉMONTÉ VALVE - OBUS	251
OUTILS À FORMER LES COLLETS	249
OUTILS POUR CAPTEURS DE PLUIE ET DE LUMINOSITÉ	260

OUTILS POUR EXTRACTION DE FICHES DE CONNECTEURS	240
OUTILS POUR LA MAINTENANCE D'AIRBAGS	256
OUTILS POUR LE DÉMONTAGE DE GARNITURES	255

P

PANNEAUX PERFORÉS	14
PERCEUSE RÉVERSIBLE 3/8"	144
PÈSE-ACIDE	240
PÈSE-ANTIGEL	245
PIÈCES DÉTACHÉES POUR COMPRESSEUR DE RESSORT	250
PIÈCES DÉTACHÉES POUR CRICS	228
PIÈCES DÉTACHÉES POUR DESSERTS	16
PIÈCES DÉTACHÉES POUR SERVANTES	12
PIED À COULISSE POUR DISQUES DE FREINS	250
PIED À COULISSE UNIVERSEL	174
PINCE À DÉGRAFER	255
PINCE À GAZ	209
PINCE À MASSE D'ÉQUILIBRAGE	251
PINCE À RIVETER	206
PINCE CLIP GARNITURE COURBÉE	255
PINCE EMPORTE PIÈCE REVOLVER	206
PINCE MULTIPRISE ISOLÉE	216
PINCE POUR DURITS DE CARBURANT	244
PINCE POUR SILENT-BLOCS D'ÉCHAPPEMENT	247
PINCE SERRE TUBES	209
PINCES À BECS	165-224
PINCES À BECS EFFILÉS	224
PINCES À DÉNUDER	215
PINCES À SERTIR	214
PINCES ISOLÉES	216
PINCES CIRCLIPS®	166
PINCES COUPANTES	163-225
PINCES COUPANTES ISOLÉES	216
PINCES DE PREHENSION	164
PINCES MULTIPRISES	162
PINCES POUR COLLIERS AUTOSERRANTS	243
PINCES UNIVERSELLES	162
PINCES UNIVERSELLES ISOLÉES	217
PINCES-ÉTAUX	168
PISTOLET À GRAISSE	207
PISTOLET À SILICONE	207-263
PLAN DE TRAVAIL À REBORDS	12
PLATEAUX MAGNÉTIQUES EXTENSIBLES	14
PLATEAUX POUR SERVANTE	12
POIGNÉE ARTICULÉE 3/4"	97
POIGNÉE COULISSANTE 1"	100
POIGNÉE COULISSANTE 1/2"	87
POIGNÉE COULISSANTE 1/4"	59
POIGNÉE COULISSANTE 3/4"	96
POIGNÉE COULISSANTE 3/8"	70
POIGNÉE EMMANCHÉE 1/4"	59
POIGNÉE POUR SERVANTE	12
POIGNÉES ARTICULÉES 1/2"	85
POIGNÉES ARTICULÉES 3/8"	70
POIGNÉES COUDÉES 1/2"	86
POINTE CARRÉE	174
POINTEAUX	182
POINTES À TRACER	175
POINTES DE RECHANGE	221
PONCEUSES ORBITALES	146
PORTE-BATTERIE UNIVERSEL	239
PORTE-DOUILLES 1/4"	135
PORTE-EMBOUTS	135
PRESENTOIRS	265
PROJECTEURS	196
PROTECTION DE CALANDRE	230
PROTECTION DE TABLEAU DE BORDS	262
PURGEUR DE FREIN À DÉPRESSION	248

R

RACK DE 10 DOUILLES 1/2" MÉTRIQUES	78
RACK DOUILLES/CLÉS	15
RACK MAGNÉTIQUE	15
RALLONGE DOUILLES IMPACT 1"	156
RALLONGES 1"	101
RALLONGES 1/2"	87
RALLONGES 1/4"	59
RALLONGES 3/4"	97
RALLONGES 3/8"	70
RALLONGES IMPACT 1/2"	151
RALLONGES IMPACT 3/4"	153
RAMPE D'ÉCLAIRAGE À LEDS	200
RÉDUCTEUR 1" - 3/4"	101
RÉDUCTEUR 1/2" - 3/8"	88
RÉDUCTEUR 3/4" - 1/2"	97
RÉDUCTEUR 3/8" - 1/4"	71
RÉDUCTEURS IMPACT	154
RÉGLET FLEXIBLE	174
RIVETUSE PNEUMATIQUE	146
RODOIRS DE SOUPAPE	246
ROULETTES POUR CHARIOT DE VISITE	229

S

SAC À DOS À ROULETTES	17
SANGLE À CLIQUET	257
SANGLES DE RECHANGE	210
SCIES	186
SERINGUE POUR CHANGEMENT D'HUILE	232
SERINGUE POUR CHANGEMENT DE FLUIDES	248
SERRURE + CLÉS POUR SERVANTES	12
SERVANTES	9
SERVANTES D'ATELIER	15
SERVANTES LARGES	8
STETHOSCOPE	246
STICKERS	267
SUPPORT AU SOL	197
SUPPORT MAGNÉTIQUE RANGE OUTILS	142
SUPPORT MOBILE POUR PARE-BRISE	257

T

TABLETTE INCLINÉE	265
TABLETTE POUR TOURNEVIS	265
TENAILLES RUSSES	168-275
TESTEUR DE LIQUIDE DE FREIN	248
TESTEUR DE PRESSION DE PNEUS	252
TESTEUR DE SYSTÈME DE REFRROIDISSEMENT	245
TESTEUR DE TENSION	242
TESTEUR MULTIFONCTIONS	242
TESTEUR VAT	242
THERMOMÈTRE INFRAROUGE	240
TIROIR POUR ÉTABLI	13
TIROIRS POUR SERVANTES	12
TOURNEVIS	108
TOURNEVIS DE PRÉCISION	222
TOURNEVIS ISOLÉS 1000 VOLTS	219
TOURNEVIS PORTE-EMBOUTS	132
TOURNEVIS PORTE-LAMES	135
TOURNEVIS PRIMO	114
TOURNEVIS TESTEUR	220
TRÉPIED	197

V

VALISE DE MAINTENANCE	204
VENTOUSE À POMPE PL	258
VENTOUSE DE MAINTIEN PARE BRISE	258
VENTOUSE MULTI-USAGES	259
VENTOUSES DE MAINTIEN VITRE LATÉRALE	259
VILEBREQUIN 1/2"	86
VILEBREQUIN 3/8"	69
VIS POUR EXTRACTEUR	211

E003601.....	175	E030104.....	64	E030313.....	63	E030944.....	73	E031803.....	67	E031984.....	92
E010101.....	9	E030105.....	64	E030314.....	63	E030945.....	73	E031804.....	66	E032001.....	90
E010105.....	8	E030106.....	64	E030315.....	63	E030946.....	73	E031805.....	66	E032101.....	237
E010108.....	15	E030107.....	64	E030316.....	63	E030947.....	73	E031806.....	66	E032102.....	237
E010118.....	12	E030108.....	64	E030317.....	63	E030948.....	73	E031807.....	75	E032103.....	91
E010119.....	12	E030109.....	64	E030318.....	63	E030949.....	73	E031821.....	67	E032201.....	81
E010121.....	12	E030110.....	64	E030322.....	63	E030950.....	73	E031901.....	93	E032203.....	91
E010128.....	16	E030111.....	64	E030508.....	58	E030951.....	73	E031902.....	93	E032401.....	237
E010129.....	16	E030112.....	65	E030509.....	59	E030952.....	73	E031903.....	93	E032402.....	237
E010131.....	9	E030113.....	65	E030601.....	58	E030953.....	73	E031904.....	93	E032701.....	85
E010136.....	16	E030114.....	65	E030602.....	58	E031105.....	74	E031905.....	93	E032702.....	86
E010161.....	12	E030115.....	65	E030605.....	58	E031301.....	73	E031906.....	93	E032709.....	84
E010192.....	9	E030116.....	65	E030700.....	55	E031302.....	73	E031907.....	93	E032711.....	87
E010193.....	9	E030117.....	65	E030702.....	54	E031303.....	73	E031908.....	93	E032713.....	86
E010194.....	10	E030118.....	65	E030703.....	64	E031304.....	73	E031909.....	93	E032714.....	86
E010201.....	17	E030119.....	65	E030704.....	64	E031305.....	73	E031910.....	93	E032801.....	84
E010202.....	17	E030120.....	65	E030707.....	54	E031306.....	73	E031911.....	93	E032802.....	85
E010203.....	17	E030121.....	65	E030715.....	57	E031307.....	73	E031912.....	93	E032803.....	85
E010204.....	17	E030122.....	65	E030727.....	56	E031308.....	73	E031913.....	93	E032804.....	85
E010209.....	17	E030123.....	65	E030901.....	75	E031309.....	73	E031914.....	93	E032805.....	85
E010304.....	18	E030124.....	65	E030902.....	75	E031310.....	73	E031915.....	93	E032808.....	84
E010305.....	18	E030125.....	65	E030903.....	75	E031311.....	73	E031916.....	93	E032900.....	77
E010402.....	13	E030126.....	65	E030904.....	75	E031312.....	73	E031917.....	93	E032902.....	78
E010404.....	13	E030127.....	65	E030905.....	75	E031313.....	73	E031918.....	93	E032904.....	80
E010405.....	13	E030128.....	65	E030906.....	75	E031334.....	73	E031919.....	93	E032906.....	80
E010601.....	18	E030129.....	64	E030907.....	75	E031501.....	74	E031920.....	93	E032907.....	78
E010602.....	18	E030130.....	64	E030908.....	75	E031502.....	74	E031921.....	93	E032908.....	77
E011001.....	15	E030131.....	64	E030909.....	76	E031503.....	74	E031922.....	93	E032909.....	77
E020101.....	186	E030132.....	64	E030910.....	76	E031504.....	74	E031923.....	93	E032911.....	50
E020103.....	187	E030133.....	64	E030911.....	76	E031505.....	74	E031924.....	93	E032922.....	81
E020301.....	192	E030134.....	64	E030912.....	76	E031506.....	74	E031925.....	93	E032924.....	81
E020302.....	192	E030142.....	65	E030913.....	76	E031507.....	74	E031926.....	93	E032936.....	80
E020303.....	192	E030143.....	65	E030914.....	76	E031508.....	74	E031927.....	92	E032937.....	83
E020304.....	192	E030144.....	65	E030915.....	76	E031509.....	74	E031928.....	92	E032938.....	83
E020305.....	206	E030145.....	65	E030916.....	76	E031510.....	74	E031929.....	92	E032939.....	82
E020306.....	193	E030146.....	65	E030917.....	76	E031511.....	74	E031930.....	92	E032940.....	82
E020307.....	193	E030147.....	65	E030918.....	76	E031512.....	74	E031931.....	92	E032941.....	80
E020308.....	164	E030148.....	65	E030919.....	76	E031513.....	74	E031932.....	92	E032942.....	83
E020309.....	164	E030149.....	65	E030920.....	76	E031514.....	74	E031933.....	92	E032943.....	82
E020310.....	164	E030150.....	64	E030921.....	76	E031515.....	74	E031934.....	92	E033503.....	99
E020602.....	188	E030151.....	64	E030922.....	76	E031516.....	74	E031935.....	92	E033504.....	99
E020603.....	188	E030201.....	61	E030923.....	76	E031517.....	74	E031936.....	89	E033505.....	99
E020604.....	188	E030202.....	61	E030924.....	76	E031518.....	74	E031936C.....	274	E033506.....	99
E020605.....	188	E030203.....	61	E030925.....	76	E031519.....	74	E031937.....	89	E033507.....	99
E020607.....	188	E030204.....	61	E030926.....	76	E031520.....	74	E031938.....	89	E033508.....	99
E020608.....	188	E030205.....	61	E030927.....	76	E031521.....	74	E031967.....	94	E033509.....	99
E020609.....	188	E030206.....	61	E030928.....	75	E031522.....	74	E031968.....	94	E033510.....	99
E020610.....	189	E030207.....	61	E030929.....	75	E031523.....	74	E031969.....	94	E033511.....	99
E020611.....	187	E030210.....	61	E030930.....	75	E031524.....	74	E031970.....	94	E033512.....	99
E020612.....	187	E030211.....	61	E030931.....	75	E031525.....	74	E031971.....	94	E033513.....	99
E020613.....	187	E030216.....	63	E030932.....	76	E031526.....	74	E031972.....	94	E033514.....	99
E020901.....	193	E030217.....	63	E030933.....	72	E031527.....	74	E031973.....	94	E033515.....	99
E020902.....	190	E030218.....	63	E030934.....	75	E031528.....	74	E031974.....	94	E033516.....	99
E020903.....	190	E030219.....	63	E030935.....	73	E031602.....	70	E031975.....	94	E033517.....	99
E020904.....	190	E030220.....	63	E030936.....	73	E031603.....	70	E031976.....	94	E033518.....	99
E020905.....	190	E030221.....	63	E030937.....	73	E031604.....	69	E031977.....	94	E033801.....	98
E020906.....	190	E030222.....	63	E030938.....	73	E031612.....	68	E031978.....	94	E033802.....	98
E020907.....	191	E030223.....	63	E030939.....	73	E031614.....	71	E031979.....	94	E033803.....	101
E020908.....	191	E030224.....	63	E030940.....	73	E031701.....	68	E031980.....	94	E033804.....	97
E030101.....	64	E030310.....	63	E030941.....	73	E031702.....	69	E031981.....	94	E034101.....	101
E030102.....	64	E030311.....	63	E030942.....	73	E031703.....	69	E031982.....	93	E034102.....	101
E030103.....	64	E030312.....	63	E030943.....	73	E031706.....	68	E031983.....	93	E034103.....	101

INDEX ALPHANUMÉRIQUE

E034104.....	101	E050106.....	215	E090104.....	209	E110110.....	25	E110935.....	29	E112816.....	42	E113256.....	34
E034105.....	101	E050301.....	214	E090105.....	209	E110111.....	25	E110936.....	32	E112817.....	42	E113257.....	34
E034106.....	101	E050302.....	214	E090106.....	208	E110113.....	25	E110937.....	32	E112818.....	43	E113258.....	34
E034107.....	101	E050504.....	216	E090107.....	208	E110115.....	25	E110938.....	32	E112819.....	43	E113259.....	34
E034108.....	101	E050406.....	216	E090108.....	208	E110201.....	23	E110939.....	32	E112820.....	43	E113260.....	34
E034109.....	101	E050407.....	216	E090109.....	208	E110202.....	23	E110940.....	32	E112821.....	43	E113261.....	34
E034501.....	101	E050408.....	216	E090110.....	208	E110203.....	23	E110943.....	32	E112822.....	43	E113262.....	34
E034502.....	101	E050409.....	216	E090111.....	208	E110204.....	23	E110944.....	32	E112823.....	43	E113265.....	34
E034503.....	100	E050410.....	217	E090112.....	208	E110205.....	23	E110945.....	32	E112824.....	43	E113267.....	34
E034601.....	100	E050411.....	217	E090113.....	208	E110206.....	23	E110961.....	45	E112825.....	43	E113268.....	34
E034701.....	100	E050412.....	217	E090114.....	208	E110300.....	24	E110961.....	205	E112826.....	43	E113272.....	34
E034801.....	51	E050413.....	217	E090115.....	208	E110302.....	24	E110962.....	45	E112827.....	43	E113275.....	34
E034802.....	52	E050414.....	217	E090116.....	208	E110303.....	26	E110962.....	205	E112828.....	43	E113279.....	34
E034805.....	51	E050415.....	216	E090302.....	172	E110304.....	25	E111100.....	33	E112829.....	43	E113281.....	34
E034806.....	19	E050416.....	217	E090303.....	206	E110306.....	24	E111101.....	29	E112830.....	43	E113282.....	34
E034806.....	204	E050502.....	217	E090401.....	205	E110309.....	24	E111102.....	30	E112831.....	43	E113285.....	34
E034835.....	19	E050608.....	219	E090402.....	205	E110310.....	24	E111103.....	32	E112832.....	43	E113286.....	34
E034837.....	78	E051301.....	241	E090403.....	205	E110313.....	24	E111104.....	31	E112901.....	42	E113287.....	34
E034853.....	50	E051401.....	199	E090404.....	205	E110323.....	24	E111106.....	28	E112902.....	42	E113288.....	34
E034855.....	53	E051401.....	231	E090501.....	221	E110326.....	24	E111107.....	28	E112903.....	42	E113289.....	35
E040601.....	150	E051402.....	231	E090502.....	221	E110327.....	24	E111108.....	30	E113200.....	22	E113290.....	35
E041101.....	155	E051501.....	231	E090701.....	207	E110701.....	26	E111115.....	33	E113201.....	22	E113291.....	35
E041102.....	155	E051601.....	193	E090702.....	207	E110702.....	26	E111201.....	34	E113202.....	22	E113292.....	35
E041103.....	155	E069253.....	118	E090703.....	207	E110703.....	26	E111202.....	34	E113204.....	22	E113293.....	35
E041104.....	155	E080205.....	163	E090703.....	263	E110704.....	26	E111203.....	34	E113205.....	22	E113294.....	35
E041105.....	155	E080206.....	163	E090705.....	207	E110705.....	26	E111220.....	36	E113206.....	22	E113295.....	35
E041106.....	155	E080207.....	163	E096002.....	211	E110706.....	26	E111222.....	35	E113207.....	22	E113296.....	35
E041301.....	155	E080208.....	163	E096003.....	211	E110707.....	26	E111406.....	35	E113208.....	22	E113297.....	35
E041302.....	155	E080209.....	163	E096004.....	211	E110708.....	26	E111500.....	37	E113209.....	22	E113298.....	35
E041303.....	155	E080210.....	163	E096005.....	211	E110709.....	26	E111501.....	37	E113210.....	22	E113299.....	35
E041501.....	154	E080211.....	163	E096006.....	211	E110710.....	26	E111502.....	37	E113211.....	22	E113300.....	28
E041502.....	154	E080407.....	165	E096007.....	211	E110711.....	26	E111503.....	37	E113212.....	22	E113301.....	28
E041503.....	154	E080408.....	165	E096008.....	211	E110901.....	30	E111708.....	38	E113213.....	22	E113302.....	28
E041505.....	60	E080409.....	164	E096009.....	211	E110902.....	30	E111709.....	38	E113214.....	22	E113303.....	28
E041506.....	71	E080410.....	164	E096010.....	211	E110903.....	30	E111710.....	38	E113215.....	22	E113304.....	28
E041507.....	88	E080411.....	165	E096011.....	211	E110904.....	30	E111714.....	38	E113216.....	22	E113305.....	28
E041601.....	148	E080412.....	165	E096012.....	211	E110905.....	30	E112201.....	39	E113217.....	22	E113306.....	28
E041602.....	148	E080503.....	162	E100103.....	139	E110906.....	30	E112301.....	43	E113218.....	22	E113307.....	28
E041603.....	148	E080504.....	162	E100104.....	139	E110907.....	30	E112501.....	44	E113219.....	22	E113308.....	28
E041604.....	150	E080505.....	162	E100105.....	138	E110908.....	30	E112601.....	45	E113220.....	22	E113309.....	28
E041605.....	150	E080701.....	169	E100106.....	138	E110909.....	30	E112602.....	45	E113221.....	22	E113310.....	28
E041644.....	150	E080801.....	161	E100107.....	138	E110910.....	30	E112603.....	45	E113222.....	22	E113311.....	28
E041647.....	156	E080815.....	160	E100108.....	138	E110911.....	30	E112604.....	45	E113223.....	22	E113312.....	23
E041648.....	156	E080816.....	160	E100109.....	138	E110912.....	30	E112605.....	44	E113224.....	22	E113313.....	23
E041649.....	52	E080817.....	160	E100110.....	138	E110914.....	31	E112606.....	44	E113225.....	22	E113314.....	23
E042204.....	157	E080818.....	160	E100115.....	246	E110916.....	31	E112607.....	44	E113226.....	22	E113315.....	23
E042207.....	157	E080819.....	161	E100116.....	246	E110917.....	31	E112703.....	44	E113228.....	22	E113316.....	23
E042208.....	157	E080820.....	166	E100203.....	139	E110918.....	31	E112801.....	42	E113229.....	22	E113317.....	23
E042209.....	157	E080821.....	161	E100204.....	139	E110919.....	31	E112802.....	42	E113230.....	23	E113318.....	23
E042211.....	157	E084648.....	162	E100501.....	138	E110921.....	31	E112803.....	42	E113235.....	23	E113319.....	23
E042213.....	157	E084649.....	162	E100502.....	138	E110923.....	31	E112804.....	42	E113236.....	23	E113321.....	37
E042215.....	157	E084807.....	168	E100503.....	138	E110924.....	29	E112805.....	42	E113238.....	24	E113322.....	37
E042216.....	157	E084808.....	168	E100504.....	138	E110925.....	29	E112806.....	42	E113239.....	24	E113323.....	37
E042304.....	157	E084809.....	168	E100505.....	138	E110926.....	29	E112807.....	42	E113240.....	24	E113324.....	37
E042307.....	157	E084812.....	168	E100506.....	138	E110927.....	29	E112808.....	42	E113241.....	24	E113325.....	37
E042308.....	157	E084813.....	168	E110101.....	22	E110928.....	29	E112809.....	42	E113242.....	24	E113326.....	37
E042310.....	157	E084815.....	169	E110102.....	22	E110929.....	29	E112810.....	42	E113250.....	34	E113328.....	37
E042401.....	157	E084815.....	169	E110103.....	22	E110930.....	29	E112811.....	42	E113251.....	34	E113329.....	37
E042402.....	156	E084816.....	169	E110104.....	22	E110931.....	29	E112812.....	42	E113252.....	34	E113358.....	23
E050103.....	215	E084816.....	169	E110106.....	25	E110932.....	29	E112813.....	42	E113253.....	34	E113359.....	23
E050104.....	215	E090101.....	210	E110108.....	25	E110933.....	29	E112814.....	42	E113254.....	34	E113360.....	23
E050105.....	215	E090102.....	210	E110109.....	25	E110934.....	29	E112815.....	42	E113255.....	34	E113361.....	23

INDEX ALPHANUMÉRIQUE

E117267.....91	E117388.....43	E117762.....220	E120102.....121	E130102.....130	E150902.....205	E160905.....104
E117268.....91	E117391.....43	E117763.....220	E120103.....121	E130103.....130	E151002.....180	E160906.....104
E117269.....91	E117392.....43	E117764.....221	E120301.....118	E130104.....130	E151003.....180	E160907.....105
E117270.....91	E117394.....43	E117767.....220	E120302.....118	E130105.....130	E151004.....180	E160908.....107
E117271.....91	E117395.....43	E117768.....130	E120303.....118	E131601.....132	E154665.....178	E160909.....107
E117272.....91	E117688.....61	E117771.....131	E120304.....118	E131608.....132	E154667.....178	E160910.....218
E117273.....91	E117700.....26	E117772.....131	E120305.....118	E131609.....135	E154668.....178	E160911.....218
E117274.....91	E117701.....26	E117773.....131	E120901.....122	E131701.....128	E154669.....178	E160912.....218
E117275.....91	E117702.....26	E117774.....131	E121101.....119	E131702.....129	E154670.....178	E160920.....113
E117276.....91	E117703.....26	E117775.....131	E121102.....122	E131705.....128	E154672.....178	E160921.....113
E117277.....91	E117704.....26	E117776.....131	E121103.....122	E131709.....128	E154673.....178	E160922.....113
E117278.....91	E117705.....26	E117777.....131	E121105.....127	E131710.....129	E154674.....178	E160923.....113
E117279.....91	E117706.....26	E117778.....131	E121215.....126	E140101.....173	E160101.....108	E160924.....112
E117280.....91	E117707.....26	E117779.....131	E121216.....126	E140102.....173	E160102.....108	E160926.....114
E117281.....91	E117708.....26	E117780.....131	E121217.....126	E140103.....173	E160103.....108	E161101.....220
E117282.....91	E117709.....26	E117781.....131	E121218.....126	E140104.....173	E160104.....108	E161102.....222
E117283.....91	E117710.....26	E117782.....131	E121219.....126	E140105.....173	E160201.....108	E161108.....222
E117284.....91	E117711.....26	E117783.....131	E121220.....126	E140106.....173	E160202.....108	E161109.....223
E117285.....91	E117712.....26	E117784.....131	E121221.....126	E140601.....174	E160203.....108	E161110.....116
E117286.....91	E117713.....26	E117785.....131	E121222.....126	E140801.....174	E160204.....108	E161111.....116
E117287.....91	E117714.....26	E117786.....131	E121223.....126	E140902.....175	E160205.....108	E161112.....135
E117288.....91	E117715.....26	E117787.....131	E121224.....126	E142301.....173	E160206.....108	E161113.....135
E117289.....91	E117716.....26	E117816.....120	E121226.....126	E142302.....173	E160250.....114	E161114.....174
E117290.....91	E117717.....26	E117820.....209	E121227.....126	E142303.....173	E160252.....114	E161115.....134
E117291.....91	E117718.....26	E117821.....209	E121228.....126	E142401.....172	E160253.....114	E164978.....108
E117292.....91	E117719.....26	E117822.....209	E121229.....125	E150101.....179	E160254.....114	E164983.....108
E117293.....61	E117720.....27	E117823.....209	E121230.....125	E150102.....179	E160255.....114	E165006.....108
E117294.....61	E117721.....27	E117824.....209	E121501.....116	E150103.....179	E160256.....114	E165016.....108
E117295.....61	E117722.....27	E117825.....209	E121502.....116	E150104.....179	E160301.....110	E165017.....108
E117296.....61	E117723.....27	E117827.....210	E121503.....116	E150105.....179	E160302.....110	E165093.....108
E117297.....61	E117724.....27	E117828.....210	E121504.....116	E150106.....179	E160303.....110	E165096.....108
E117298.....61	E117725.....27	E117829.....210	E121505.....116	E150107.....179	E160304.....110	E165098.....108
E117299.....61	E117726.....27	E117830.....210	E121506.....116	E150108.....179	E160305.....110	E165138.....108
E117350.....61	E117727.....27	E117830.....210	E121507.....116	E150109.....179	E160340.....115	E165141.....108
E117351.....61	E117728.....27	E117877.....224	E121517.....116	E150110.....179	E160341.....115	E165204.....110
E117352.....61	E117729.....27	E117878.....224	E121601.....123	E150111.....180	E160342.....115	E165206.....110
E117353.....61	E117730.....27	E117879.....225	E121602.....123	E150112.....180	E160401.....111	E165207.....110
E117354.....61	E117731.....27	E117880.....225	E121603.....123	E150113.....180	E160402.....111	E165209.....110
E117355.....59	E117732.....27	E117881.....151	E121604.....123	E150114.....180	E160403.....111	E165319.....111
E117356.....59	E117733.....27	E117882.....225	E121605.....123	E150115.....181	E160410.....115	E165335.....111
E117358.....60	E117734.....27	E117883.....224	E121606.....123	E150116.....181	E160411.....115	E165337.....111
E117359.....60	E117735.....27	E117884.....151	E121607.....123	E150301.....181	E160412.....115	E165340.....109
E117360.....60	E117736.....27	E117903.....214	E121608.....123	E150302.....181	E160501.....109	E165395.....109
E117361.....70	E117737.....27	E117905.....44	E121609.....123	E150303.....181	E160502.....109	E165396.....109
E117363.....70	E117738.....27	E117906.....44	E121610.....124	E150304.....181	E160503.....109	E165397.....109
E117364.....70	E117739.....27	E117908.....167	E121611.....124	E150305.....181	E160504.....109	E165398.....109
E117365.....71	E117740.....27	E117909.....167	E121612.....124	E150306.....181	E160505.....109	E165399.....109
E117366.....72	E117741.....27	E117910.....167	E121613.....124	E150307.....181	E160506.....109	E165400.....109
E117367.....72	E117742.....27	E117911.....167	E121614.....124	E150308.....181	E160507.....109	E165404.....109
E117368.....43	E117743.....27	E117912.....166	E121615.....124	E150501.....182	E160508.....109	E165406.....110
E117370.....28	E117744.....27	E117913.....166	E121616.....124	E150502.....182	E160509.....109	E165407.....110
E117371.....28	E117750.....189	E117914.....166	E121617.....123	E150503.....183	E160510.....109	E165408.....111
E117372.....28	E117751.....189	E117915.....166	E121701.....125	E150504.....183	E160511.....109	E165409.....111
E117373.....28	E117752.....189	E117916.....167	E121702.....125	E150701.....183	E160601.....109	E165410.....219
E117374.....28	E117753.....189	E117917.....167	E121703.....125	E150702.....183	E160801.....134	E165411.....219
E117376.....37	E117754.....189	E117918.....167	E121704.....125	E150703.....183	E160802.....133	E165412.....219
E117377.....28	E117755.....189	E117919.....167	E121705.....125	E150704.....183	E160803.....134	E165413.....219
E117378.....28	E117756.....189	E117920.....167	E121706.....125	E150801.....178	E160804.....133	E165414.....219
E117381.....35	E117757.....189	E117921.....167	E121707.....125	E150802.....178	E160901.....106	E165415.....219
E117382.....35	E117758.....189	E117922.....167	E121708.....125	E150803.....178	E160902.....105	E165416.....219
E117386.....39	E117759.....189	E117923.....167	E121709.....124	E150901.....205	E160903.....105	E165417.....219
E117387.....39	E117760.....189	E120101.....121	E130101.....130	E150901.....230	E160904.....104	E165418.....219

E165419.....	219	E200123.....	228	E200505.....	243	E201125.....	251	E214563.....	190
E165420.....	219	E200124.....	229	E200505.....	243	E201201.....	255	E220104.....	18
E165421.....	219	E200131.....	206	E200506.....	243	E201202.....	255	E220107.....	18
E165422.....	219	E200131.....	229	E200506.....	243	E201203.....	255	E230104.....	142
E165476.....	108	E200135.....	228	E200507.....	243	E201204.....	255	E230110.....	142
E165479.....	108	E200136.....	228	E200507.....	243	E201205.....	256	E230115.....	143
E165480.....	108	E200137.....	256	E200508.....	243	E201206.....	256	E230116.....	143
E165481.....	108	E200140.....	228	E200508.....	243	E201207.....	256	E230120.....	143
E165482.....	108	E200141.....	228	E200509.....	243	E201209.....	263	E230125.....	144
E165483.....	108	E200143.....	229	E200509.....	243	E201211.....	256	E230126.....	144
E165484.....	109	E200144.....	229	E200510.....	243	E201403.....	197	E230201.....	146
E165490.....	132	E200145.....	229	E200510.....	243	E201406.....	199	E230202.....	146
E168733.....	135	E200201.....	236	E200511.....	245	E201408.....	200	E230203.....	147
E169804.....	206	E200202.....	233	E200512.....	230	E201409.....	201	E230204.....	147
E184179.....	168	E200203.....	234	E200513.....	52	E201410.....	201	E230301.....	127
E184181.....	168	E200204.....	234	E200514.....	78	E201411.....	196	E230301.....	249
E184182.....	168	E200205.....	234	E200515.....	79	E201412.....	196	E230402.....	144
E184195.....	191	E200206.....	234	E200516.....	79	E201413.....	201	E230502.....	145
E184280.....	221	E200207.....	234	E200517.....	244	E201414.....	199	E230503.....	145
E184302.....	168	E200208.....	234	E200518.....	246	E201414.....	231	E230508.....	145
E184690.....	162	E200209.....	234	E200519.....	244	E201415.....	198	E230603.....	146
E187366.....	44	E200210.....	234	E200520.....	246	E201424.....	197	E230901.....	145
E187368.....	44	E200211.....	234	E200521.....	244	E201425.....	197	E231015.....	142
E187470.....	44	E200212.....	234	E200522.....	79	E201426.....	200	E231101.....	149
E187472.....	44	E200213.....	234	E200523.....	245	E201427.....	198	E231102.....	149
E187473.....	44	E200214.....	234	E200524.....	243	E201429.....	200	E231103.....	153
E189871.....	165	E200215.....	234	E200525.....	243	E201431.....	197	E418226.....	182
E189872.....	165	E200216.....	234	E200526.....	243	E201432.....	198	E418227.....	182
E189874.....	164	E200219.....	235	E200601.....	247	E201501.....	257	E418228.....	182
E189874.....	214	E200227.....	232	E200901.....	248	E201502.....	257	E418230.....	182
E189875.....	163	E200228.....	232	E200902.....	248	E201503.....	257	E418231.....	182
E194672.....	55	E200229.....	236	E200903.....	248	E201504.....	258	E418232.....	182
E194675.....	56	E200231.....	232	E200904.....	249	E201505.....	259	E418233.....	182
E194676.....	253	E200234.....	235	E200905.....	249	E201506.....	259	E418234.....	182
E194677.....	81	E200235.....	235	E200906.....	250	E201507.....	258	E418235.....	182
E194678.....	67	E200236.....	233	E200907.....	248	E201508.....	259	E418236.....	182
E194680.....	57	E200237.....	233	E200908.....	250	E201509.....	260	E469262.....	117
E194682.....	95	E200238.....	233	E200909.....	248	E201510.....	260	E469263.....	117
E194683.....	95	E200239.....	236	E200910.....	249	E201512.....	239	E501201.....	223
E194738.....	17	E200240.....	210	E200911.....	249	E201512.....	260	E501202.....	223
E194937.....	24	E200241.....	210	E201001.....	250	E201513.....	262	E501203.....	223
E194938.....	33	E200244.....	232	E201002.....	250	E201514.....	262		
E194940.....	106	E200245.....	235	E201003.....	250	E201515.....	261		
E194941.....	107	E200301.....	237	E201100.....	253	E201516.....	261		
E194943.....	166	E200302.....	237	E201105.....	253	E201518.....	261		
E194944.....	161	E200303.....	237	E201109.....	251	E201519.....	204		
E195561.....	189	E200306.....	238	E201110.....	251	E201519.....	263		
E195568.....	189	E200307.....	237	E201112.....	251	E201520.....	204		
E195569.....	189	E200310.....	238	E201113.....	254	E201520.....	263		
E200103.....	228	E200311.....	237	E201114.....	254	E201521.....	257		
E200105.....	228	E200312.....	237	E201115.....	252	E201522.....	262		
E200106.....	228	E200401.....	239	E201116.....	252	E201701.....	244		
E200107.....	228	E200403.....	239	E201117.....	251	E201702.....	245		
E200108.....	228	E200404.....	239	E201117.....	251	E201801.....	240		
E200109.....	228	E200405.....	240	E201118.....	251	E201802.....	242		
E200110.....	228	E200407.....	240	E201118.....	251	E201803.....	241		
E200114.....	229	E200408.....	239	E201119.....	251	E201804.....	242		
E200116.....	230	E200501.....	243	E201120.....	252	E201805.....	240		
E200117.....	228	E200502.....	245	E201121.....	253	E201806.....	242		
E200118.....	228	E200503.....	238	E201122.....	252	E201808.....	239		
E200119.....	228	E200504.....	243	E201123.....	252	E201901.....	247		
E200122.....	228	E200504.....	243	E201124.....	252	E201902.....	247		

Dotted lines for writing notes.

A series of horizontal dotted lines for writing notes, spanning the width of the page.

A series of horizontal dotted lines for taking notes.

EXPERT

by FACOM



Centre logistique européen – Damparis (39), France

VOS CONTACTS EXPERT



FR

BGI Distribution (marque Expert)

6-8, rue Gustave Eiffel
91420 MORANGIS
E-mail : clients.commandes@sbdinc.com
Tél : 01 64 54 40 20
Fax : 01 69 74 29 11

BE

Stanley Black & Decker

Belgium B.V.B.A.
Division FACOM
Egide Walschaertsstraat 16
2800 Mechelen
E-mail: facom.belgium@sbdinc.com
Tél: +32 (0)15 47 39 30

CH

Stanley Works Europe GmbH

In der Luberzen 42
CH - 8902 Urdorf
Tel: + 41 44 755 60 70
Fax: + 41 44 755 70 67



VOTRE DISTRIBUTEUR