

Fiche technique du produit

Spécifications

Harmony XB5 - tête bouton tournant à manette - Ø22 - 2 posit fixes - noir



ZB5AD2

Statut commercial: Commercialisé

Principales

Gamme de produit	Harmony XALF Harmony XB5
Type de produit ou équipement	Tête d'interrupteur
Nom de l'appareil	ZB5
Matériau de la collerette	Plastique gris foncé
Diamètre de fixation	22 mm
Type de tête	Standard
Vente par quantité indivisible	1
Forme de la tête de l'unité de signalisation	Rond
Type de commande	bouton maintenu
Profil de fonctionnement	Noir poignée standard
Information sur position de fonctionnement	2 positions 90°

Complémentaires

Largeur hors tout CAO	29 mm
Hauteur hors tout CAO	29 mm
Profondeur hors tout CAO	46 mm
Poids du produit	0,017 kg
Durée de vie mécanique	1000000 cycle
Boîte associée	XALD 1...5 découpes XALK 2...5 découpes

Code de composition électrique	C3 pour <6 contacts à l'aide desimple blocs dans montage avant C4 pour <6 contacts à l'aide desimple et double blocs dans montage avant C5 pour <5 contacts à l'aide desimple blocs dans montage avant C6 pour <5 contacts à l'aide desimple et double blocs dans montage avant C7 pour <4 contacts à l'aide desimple blocs dans montage avant C8 pour <4 contacts à l'aide desimple et double blocs dans montage avant C11 pour <3 contacts à l'aide desimple blocs dans montage avant C15 pour <1 contacts à l'aide desimple blocs dans montage avant SF1 pour <3 contacts à l'aide desimple blocs dans montage avant SR1 pour <3 contacts à l'aide desimple blocs dans montage arrière
--------------------------------	--

Présentation du produit	Élément de base
-------------------------	-----------------

Environnement

Traitement de protection	TH
Température de l'air ambiant pour le stockage	-40...70 °C
Température de l'air ambiant en fonctionnement	-40...70 °C

Catégorie de surtension	Classe II conforming to CEI 60536
Degré de protection IP	IP67 se conformer à CEI 60529 IP69 se conformer à CEI 60529 IP69K
Enclosure Type	UL type 4X/13
Tenue au nettoyage haute pression	7000000 Pa à 55 °C, distance : 0,1 m
Tenue aux chocs IK	IK06 se conformer à CEI 50102
Normes	JIS C8201-5-1 CSA C22.2 No 14 UL 508 CEI 60947-1 CEI 60947-5-4 CEI 60947-5-1 JIS C8201-1
Certifications du produit	DNV CSA BV LROS (Lloyds register of shipping) UL listed
Tenue aux vibrations	5 gn (f= 2...500 Hz) se conformer à CEI 60068-2-6
Tenue aux chocs mécaniques	30 gn (durée = 18 ms) pour accélération d'une demi-onde sinusoïdale se conformer à CEI 60068-2-27 50 gn (durée = 11 ms) pour accélération d'une demi-onde sinusoïdale se conformer à CEI 60068-2-27

Emballage

Type d'emballage 1	PCE
Nombre d'unité par paquet	1
Hauteur de l'emballage 1	3,700 cm
Largeur de l'emballage 1	5,400 cm
Longueur de l'emballage 1	6,000 cm
Poids de l'emballage (Kg)	24,000 g
Type d'emballage 2	S03
Nb produits dans l'emballage 2	200
Hauteur de l'emballage 2	30,000 cm
Largeur de l'emballage 2	30,000 cm
Longueur de l'emballage 2	40,000 cm
Poids de l'emballage 2	5,339 kg
Type d'emballage 3	P06
Nb produits dans l'emballage 3	1600
Hauteur de l'emballage 3	75,000 cm
Largeur de l'emballage 3	60,000 cm
Longueur de l'emballage 3	80,000 cm
Poids de l'emballage 3	52,604 kg

Garantie contractuelle

Garantie (en mois)	18
---------------------------	----

Schneider Electric vise à atteindre le statut de Net Zero d'ici 2050 grâce à des partenariats avec la chaîne logistique, des matériaux à faible impact et une circularité via notre campagne en cours "Use Better, Use Longer, Use Again" pour prolonger la durée de vie des produits et leur recyclabilité.

[Environmental Data expliquées >](#)

Empreinte environnementale

Empreinte carbone du cycle de vie total	0.2 kg CO2 eq.
Empreinte carbone de la phase de fabrication [A1 à A3]	0.1 kg CO2 eq.
Empreinte carbone de la phase de distribution [A4]	0 kg CO2 eq.
Empreinte carbone de la phase d'installation [A5]	0 kg CO2 eq.
Empreinte carbone de la phase d'utilisation [B2, B3, B4, B6]	0 kg CO2 eq.
Empreinte carbone de la phase de fin de vie [C1 à C4]	0 kg CO2 eq.

Use Better

Matières et Substances

Pourcentage moyen de contenu en plastique recyclé	28 %
Pourcentage moyen de teneur en métal recyclé	60 %
Emballage avec carton recyclé	Non
Emballage sans plastique	Non
Directive UE RoHS	Conforme
Règlementation REACH	Référence ne contenant pas de SVHC au-delà du seuil

Use Longer

Prolongation de vie

Réparation	Non
------------	-----

Use Again

Réemballer et réuser

Potentiel de recyclabilité, en %	23
Profil de circularité	Informations de fin de vie
Reprise	Oui

Dimensions Drawings

Dimensions

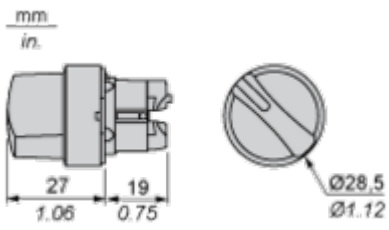

Mounting and Clearance

Panel Cut-out for Pushbuttons, Switches and Pilot Lights (Finished Holes, Ready for Installation)

Connection by Screw Clamp Terminals or Plug-in Connectors or on Printed Circuit Board



- (1) Diameter on finished panel or support
- (2) For selector switches and Emergency stop buttons, use of an anti-rotation plate type ZB5AZ902 is recommended.
- (3) $\varnothing 22.5$ mm recommended ($\varnothing 22.3 \text{ }_0^{+0.4}$) / $\varnothing 0.89$ in. recommended ($\varnothing 0.88 \text{ in. }_0^{+0.016}$)

Connections	a in mm	a in in.	b in mm	b in in.
By screw clamp terminals or plug-in connector	40	1.57	30	1.18
By Faston connectors	45	1.77	32	1.26
On printed circuit board	30	1.18	30	1.18

Detail of Lug Recess



- (1) Diameter on finished panel or support
- (2) For selector switches and Emergency stop buttons, use of an anti-rotation plate type ZB5AZ902 is recommended.
- (3) $\varnothing 22.5$ mm recommended ($\varnothing 22.3 \text{ }_0^{+0.4}$) / $\varnothing 0.89$ in. recommended ($\varnothing 0.88 \text{ in. }_0^{+0.016}$)

Pushbuttons, Switches and Pilot Lights for Printed Circuit Board Connection

Panel Cut-outs (Viewed from Installer's Side)

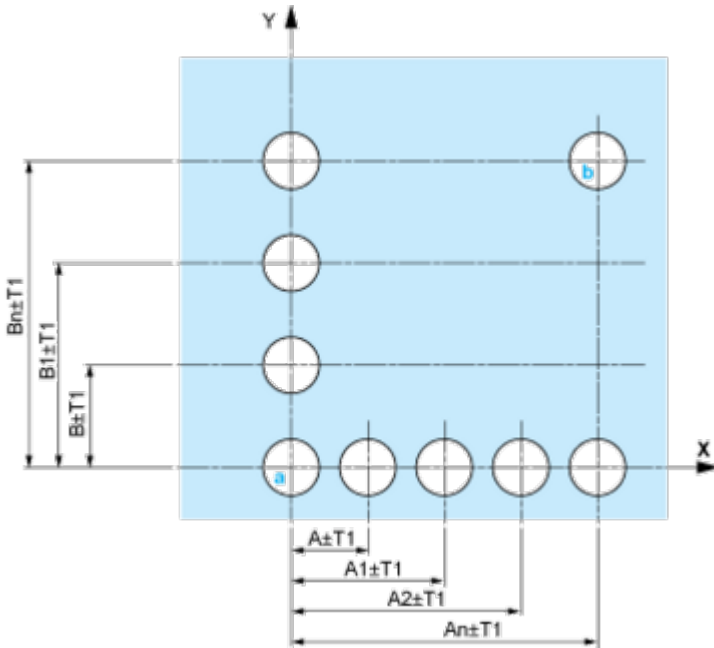

A: 30 mm min. / 1.18 in. min.

B: 40 mm min. / 1.57 in. min.

Printed Circuit Board Cut-outs (Viewed from Electrical Block Side)

Dimensions in mm



A: 30 mm min.

B: 40 mm min.

Dimensions in in.

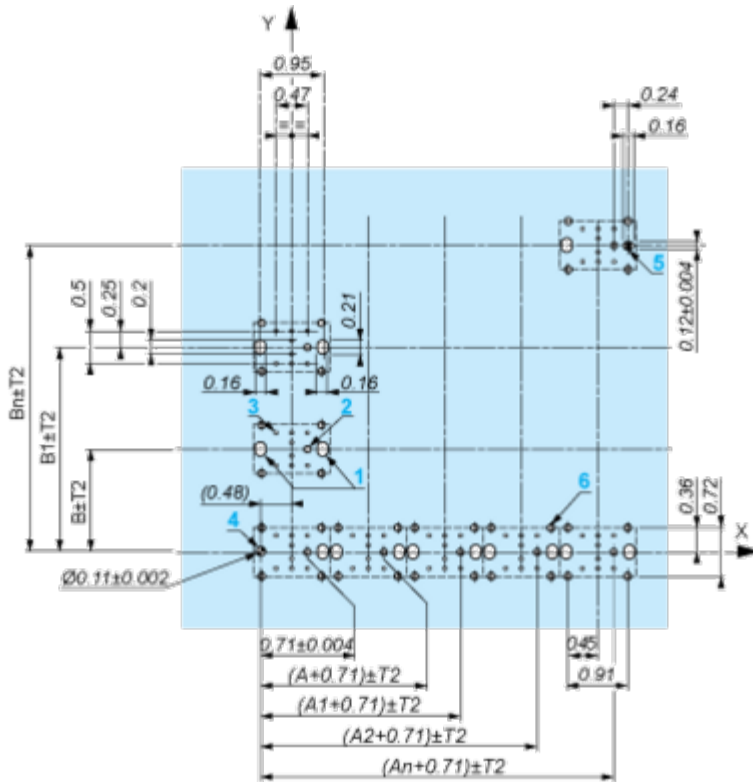

A: 1.18 in. min.
 B: 1.57 in. min.

General Tolerances of the Panel and Printed Circuit Board

The cumulative tolerance must not exceed 0.3 mm / 0.012 in.: T1 + T2 = 0.3 mm max.

Installation Precautions

- Minimum thickness of circuit board: 1.6 mm / 0.06 in.
- Cut-out diameter: 22.4 mm ± 0.1 / 0.88 in. ± 0.004
- Orientation of body/fixing collar ZB5AZ009: ± 2° 30' (excluding cut-outs marked a and b).
- Tightening torque of screws ZBZ006: 0.6 N.m (5.3 lbf.in) max.
- Allow for one ZB5AZ079 fixing collar/pillar and its fixing screws:
 - every 90 mm / 3.54 in. horizontally (X), and 120 mm / 4.72 in. vertically (Y).
 - with each selector switch head (ZB5AD*, ZB5AJ*, ZB5AG*).

The fixing centers marked a and b are diagonally opposed and must align with those marked 4 and 5.

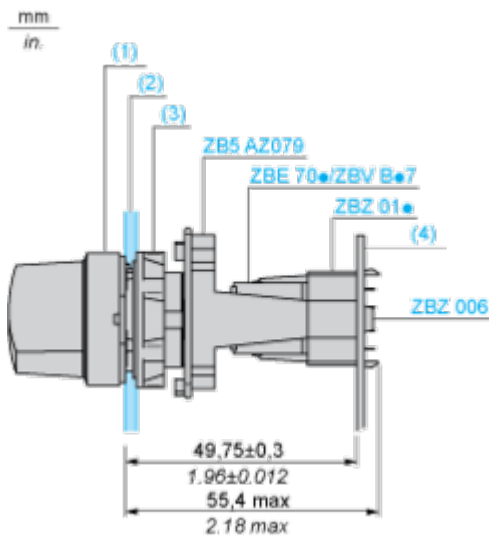

- (1) Head ZB5AD•
- (2) Panel
- (2) Nut
- (4) Printed circuit board

Mounting of Adapter (Socket) ZBZ01•

- 1 2 elongated holes for ZBZ006 screw access
- 2 1 hole \varnothing 2.4 mm \pm 0.05 / 0.09 in. \pm 0.002 for centring adapter ZBZ01•
- 3 8 \times \varnothing 1.2 mm / 0.05 in. holes
- 4 1 hole \varnothing 2.9 mm \pm 0.05 / 0.11 in. \pm 0.002, for aligning the printed circuit board (with cut-out marked **a**)
- 5 1 elongated hole for aligning the printed circuit board (with cut-out marked **b**)
- 6 4 holes \varnothing 2.4 mm / 0.09 in. for clipping in adapter ZBZ01•

Dimensions An + 18.1 relate to the \varnothing 2.4 mm \pm 0.05 / 0.09 in. \pm 0.002 holes for centring adapter ZBZ01•.

Technical Description

Electrical Composition Corresponding to Code C3



Electrical Composition Corresponding to Code C4



Electrical Composition Corresponding to Code C5



Electrical Composition Corresponding to Code C6



Electrical Composition Corresponding to Code C7



Electrical Composition Corresponding to Code C8



Electrical Composition Corresponding to Codes C9, C11, SF1 and SR1



Electrical Composition Corresponding to Code C15

1 N/O

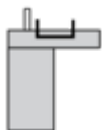

1 N/C



1 N/O + N/C or 1 N/O + N/O or 1 N/C + N/C

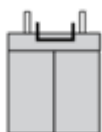

Legend

Single contact



Double contact



Light block



Possible location



Sequence of Contacts Fitted to 2-position Selector Switch Body

Position 315°



Push	Position	Top			
		Bottom			
	Location		Left	Centre	Right
	State		0	0	0
	Contacts		N/O	open	open
		N/C	closed	closed	closed

Position 45°



Push	Position	Top			
		Bottom			
	Location		Left	Centre	Right
	State		1	1	1
Contacts		N/O	closed	closed	closed
		N/C	open	open	open

Technical Illustration

Dimensions

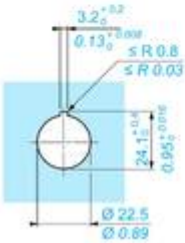
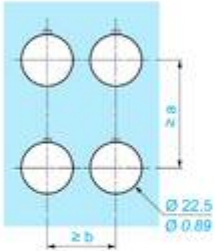
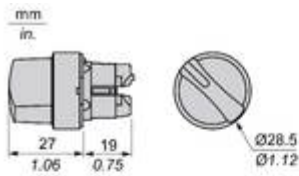

		a (mm)	a (in.)	b (mm)	b (in.)
		40	1.57	30	1.18
ZBE.....	ZBV.....				
		45	1.77	32	1.26
ZBE.....3	ZBV.....3				
		40	1.57	30	1.18
ZBE.....4	ZBV.....4				
		50	1.97	30	1.18
ZBE.....5	ZBV.....5				
		40	1.57	30	1.18
ZBE.....9	ZBV.....9				
		40	1.57	30	1.18
ZBRT•	ZBRV1				

Offer Marketing Illustration

Product benefits / Features

Caractéristiques techniques

Harmony XB5



Offer Marketing Illustration

Product benefits / Features

Bouton poussoir en plastique Harmony XB5



- 

Montage et démontage rapides et faciles
- 

Excellente connexion mécanique avec la tête de commande
- 

Différents types de connexions : borniers à vis-étrier, Push-in, connecteur Faston & broches pour circuit imprimé
- 

Robustesse pour résister aux environnements difficiles
- 

Large choix d'accessoires pour personnaliser vos panneaux

Offer Marketing Illustration

Product benefits / Features

Technical Benefits

Harmony XB5

Conformity with IEC, UL, CSA, CCC EAC, and JIS standards, as well as CE marking and marine approvals

Up to IP66, 67, 69, 69K, and type 4X protection ratings

High vibration resistance with shake-proof terminal screws



Operating temperature from -40°C to 70°C

Shock protection level up to IK06

Secure switching of inductive or heavy DC loads directly – 100 000 operations at 10A, 24V dc

Offer Marketing Illustration

Product benefits / Features

Features
Harmony XB5

-  Quick and easy assembly and disassembly
-  Excellent mechanical connection with operator head
-  Various types of connection: screw clamp, connector, Faston connector, spring terminal, or printed circuit board
-  Large set of accessories to customize your panels
-  Robustness to withstand harsh environments

Image of product / Alternate images

Alternative



